

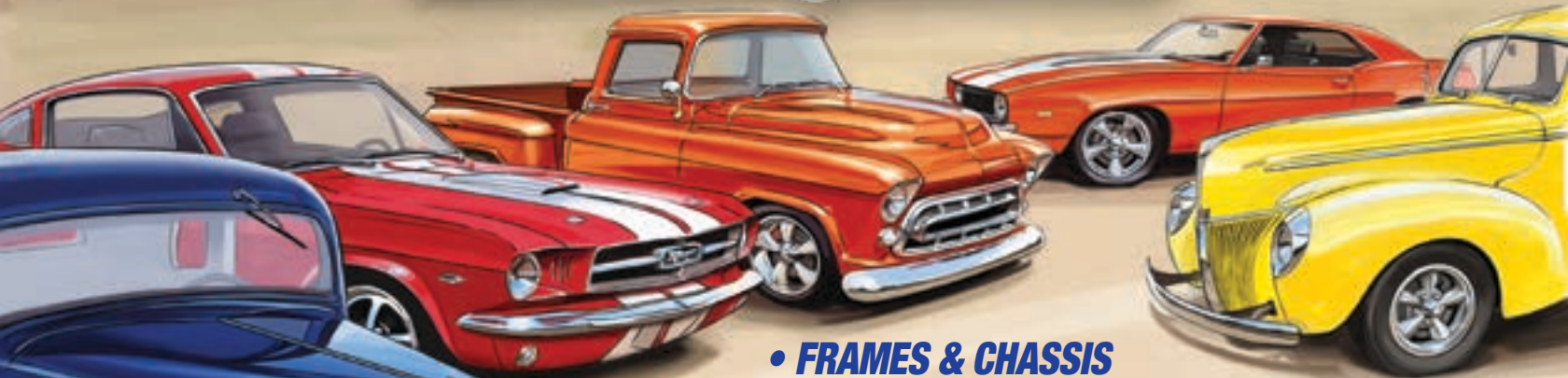

HEINZMAN

STREET ROD SHOP



- **FRAMES & CHASSIS**
- **SUSPENSION & BRAKES**
- **HOT ROD AND MUSCLE CAR PARTS**
- **WE CAN HELP BUILD YOUR HOT ROD**

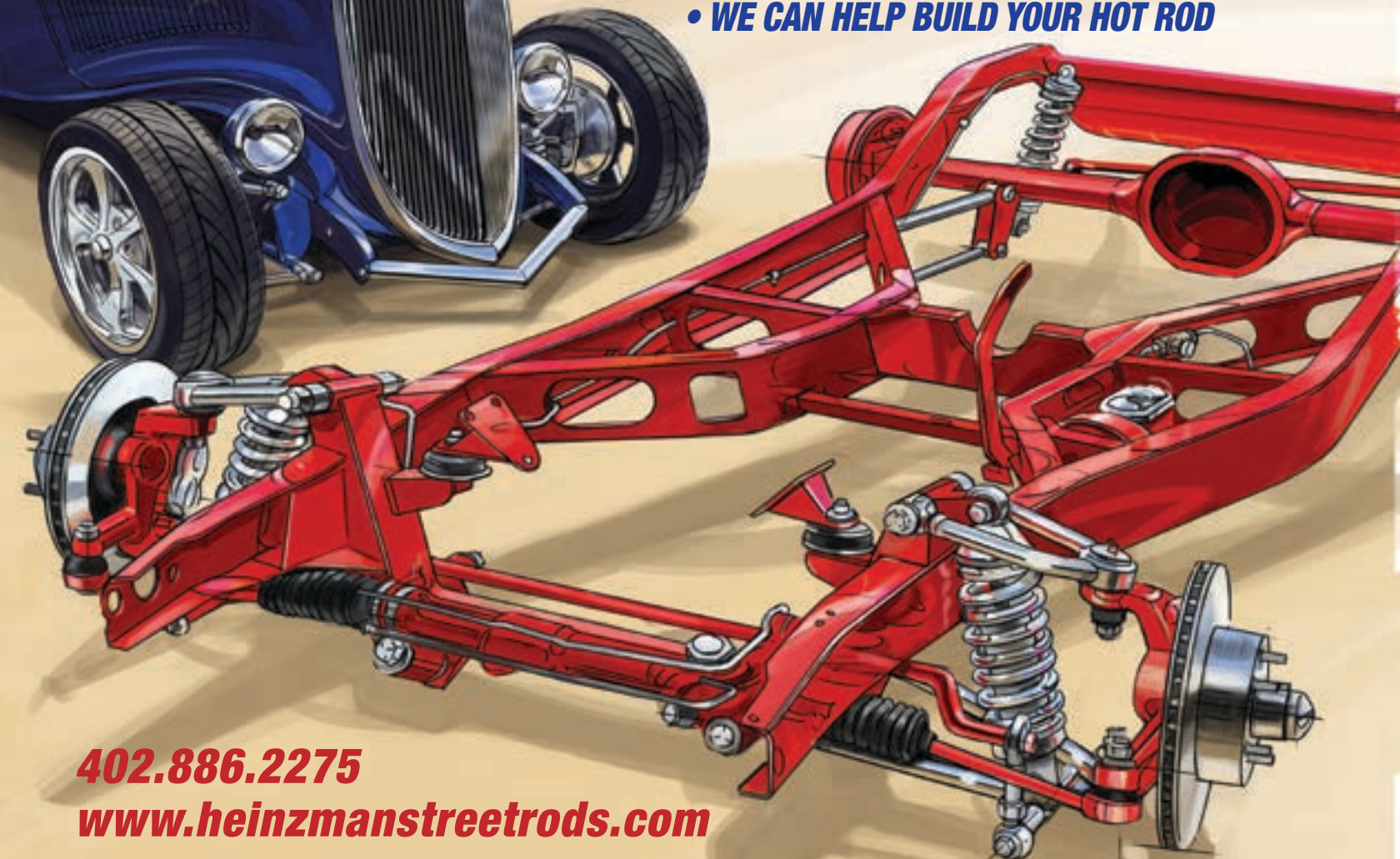

402.886.2275

www.heinzmanstreetrods.com

Catalog No.28 \$5.00



Heinzman Street Rod Shop is comprised of a number of different fabrication, paint and assembly buildings totaling about 10,000 square feet.



Heinzman's is a complete street rod and muscle car fabrication and restoration shop. No job is too big or too small!

CHASSIS CONSTRUCTION

- Restoration of vintage frames or building with all new components
- Straight-axle and independent suspensions
- Racing or cruising custom work
- Complete brake systems

CUSTOM ENGINES AND DRIVETRAINS CUSTOM FUEL SYSTEMS

- Crate engines
- Custom engine building
- Supercharger and fuel injection systems
- Flatheads, Chevy LS and Ford Cammers
- Automatic & standard transmission and linkages.

BODY AND INTERIOR CONSTRUCTION

- Full-service restoration or reproduction in steel or fiberglass
- Custom metalwork, chopped tops and custom features
- Complete show quality body and paint finishing facility
- Interiors finished in leather, wood, glass and vinyl
- Electrical services, custom dash and wiring.

AIR CONDITIONING, COOLING, CUSTOM ACCESSORIES

- Complete plumbing- standard, stainless, and braided
- Cooling systems, air conditioning and power steering
- Power accessories and sound systems



About Us...

At the Heinzman Street Rod Shop, we take great pride in fulfilling our customers needs and vision for their cars. The care we take in custom engineering makes the difference between a good street rod or muscle car and a great one.

Whether it's the chassis fabrication, the assembly area, the office, or the body shop, our staff have one thing in common... We are car people!

The Heinzman Difference

The Heinzman Street Rod Shop has been owned and operated since 1985 under the expert eye of John Heinzman, who oversees a staff of craftsmen dedicated to building the finest hand-built street rods for his customers. Forty years of experience makes the difference between knowing what works and what doesn't.

That experience also carries over to the parts we sell in our catalog. We use the parts in this catalog when building customer cars, so we know how a part works and can answer any question you have about a part we sell.

Engineering

The staff at the Heinzman Street Rod Shop knows that every vehicle is a unique combination tailored to the vision of the owner. As a mechanical engineer, John brings to the construction process the education and experience to bring together a strong and safe vehicle. One that looks right, drives right, and runs right.

Value

Anyone who knows street rods knows that mistakes are expensive. At the Heinzman Street Rod Shop, we know how to put together the right combination the first time. Our experience can make the best of your investment without compromising safety through inferior parts or workmanship.

Location

The Heinzman Street Rod Shop is located under the wide Nebraska skies about 90 miles and a 1.5 hour drive from Lincoln, NE. The nearest airport is in Grand Island, NE and is about a ten minute drive from the shop.

Ordering Information

HOW TO ORDER: Phone orders welcome. For mail orders, please include part number and a brief description of the item. Print name, address, zip code and include telephone number.

PAYMENT: Money orders or certified checks are suggested to avoid delays. VISA & Master Card welcomed. Personal checks accepted, but must clear bank before shipment is made. Please add 10% to cover shipping. Any over-payment will be refunded.

ORDERS: Under \$50.00 Add \$5.00 Freight

PRICES Prices are subject to change without notice. Nebraska residents add 5.5% tax.

SHIPPING: We ship UPS, COD unless prepaid. Purchaser pays shipping costs. Items too large for UPS will be shipped commercial truck. Please make arrangements to avoid COD charges.

CLAIMS: All claims for damage must be made with the transportation company.

GUARANTEE AND LIABILITY: Our merchandise is guaranteed free from defects in material and workmanship. Neither HEINZMAN STREET RODS nor the manufacturer shall be liable, in any way for any damage, loss, injury or other mishap, resulting from the use or mis-use or inability to use any of our products. Buyer or user assumes all liability of any kind connected with the application of our products. The foregoing statement is made in lieu of all warranties expressed or implied.

© 2023 Heinzman Street Rods

HEINZMAN STREET RODS

1305 North "C" Road
Phillips, Nebraska 68865

Phone (402) 886-2275 between 9:00 AM and 5PM CST

Fax (402) 886-2998

VISIT US AT: WWW.HEINZMANSTREETRODS.COM

The staff at Heinzman Street Rods have been building street rods (Hot Rods) for over 30 years and offer a wealth of information plus parts from the top street rod manufacturers to help you with your street rod project. Whether you need an accessory part, a rolling chassis, a complete turn key car or just have a question about your particular project, the Heinzman staff will be happy to help!

We use the parts we sell on our own cars and customer projects so you can be assured the parts in this catalog are of the highest quality and fit right

Give us a call, you'll be glad you did!

Table of Contents

1928-31 Ford Frames and Chassis	2	Bitchin Floors and Firewalls	73-74
1932 Ford Frames and Chassis	3	Hoods	75
1933-34 Ford Frame and Chassis	4	Steel Pickup Body Parts, Beds, Bed Parts, Tailgates	76-83
1928-34 Ford Suspension Parts	5-10	Radiators, Fans, Shrouds, Parts	84-85
1935-40 Ford Repro Frame	11	Gas Tanks, Gas Tank Accessories	86-87
1935-40, 41-48 Ford Exchange Frame . . .	12	Headers, LS, Limefire	88-89
1935-40 Ford Car & Truck Suspension. .	13-19	Alternator, A/C Drives, Drive Kits Pulleys	90-92
1941-48 Ford Suspension Parts	20-24	A/C Systems, Parts	93-96
1948-56 Ford Truck Suspension Parts 25-27,125		EFI Kits, Wiring Kits, Alternators	97-98
1965-70 Mustang Suspension	28-31	Dashboards, Gauges	99-100
1934-36 Chevy Suspension Parts	32-33	Power Windows, Wiper Kits	100-101
1937-39 Chevy Suspension Parts	34-35	Seat Parts	102
1940-48 Chevy Suspension Parts	35-36	ProCar Custom Seats	102
1949-54 Chevy Suspension Parts	37	Stereo, Speakers, Antennas, Horns . .	102-103
1937-59 Chevy Truck Suspension . .	38-39,125	Steering Wheels	103
1955-57 Chevy Car Suspension Parts . .	40-42	Steering Columns and Accessories	104
1962-74 Chevy Nova Suspension	43-47	Gennie Shifter, Lokar, Shifters.	105-109
1967-81 Chevy Camaro Suspension . .	48-52	Bumpers, Grilles, Chrome Trim	110-113
1964-74 Chevy Chevelle Suspension. .	53-56	Door, Deck Lid Parts	114-116
Universal Suspension Parts	57	Window Parts	116-117
Mustang II Stub Frames	58	Windshield, Wiper Parts	118-120
Mustang II Suspension Parts	59-60	Rubber Parts and Seals	117-119
Hot Rod Wheels	61	Interior and Mirrors.	121
Disc Brake Kits and Brake Parts.	62-67	Headlights and Taillights.	122-124
Wescott Fiberglass Bodies and Parts . .	68-69	NEW Classic Truck X-frame, 4-Bar kits. .	125
Pacific Steel 1932 5W Bodies and Parts. .	69	Shipping and Return Policies . . .	Inside Cover
Fenders, Patch Panels, Running Boards .	70-72		

We are a dealer for:

- | | |
|--------------------------------------|-------------------------------------|
| ABS Brakes | Shafts |
| Alan Grove | Kugel Komponenten |
| American Racing | Lecarra |
| American Auto Wire | Lokar |
| Autometer Gauges | Mac Hills Pickup Beds |
| B&M shifters | March |
| Billet Specialties | MBA Brakes |
| Bitchin Sheetmetal | Nu Relics |
| Bob Drake | Northern Classic Trucks |
| Boese Dash Panels | Pete & Jake's |
| Borgeson | Pacific Industries |
| Chassis Engineering | ProCar Seats |
| Concept One | Rock Valley |
| Cooling Components | Rod & Custom Motorsports |
| Custom Auto Sound | Rod-Tech Dash Panels |
| Dennis Carpenter | Ron Francis Wiring |
| Detail Zone Wiring | Sanderson Headers |
| Detroit Speed and Engineering | Specialty Power Windows |
| Deuce Factory | Speartech EFI |
| ECI Brakes | Tanks, Inc |
| Edelbrock | Uni-steer Steering |
| Fatman | Vintage Air |
| Flaming River | Walker Radiators |
| Ford Racing | Wheel Smith |
| Gennie Shifter | Wescott |
| GM Performance Parts | |
| Halibrand | |
| Heidt's | |
| Inland-Empire Drive | |

Table of Contents



We always have a good selection of bodies, frames and parts available. Maybe just what you need to get your project going.



COMPLETE CHASSIS

Starting at **\$9,450.00 with IFS**
\$8,500.00 with Solid Front Axle



1928-31 MODEL "A" NEW REPRODUCTION FRAMES AND CHASSIS

BASIC FRAME, *Standard features:*

1. Rails tapered front and rear like stock "A"
2. Die formed front crossmember
3. Rails center punched for fender braces, running boards, etc
4. Curved front frame horns that match original
5. Gusseted cowl supports
6. Bumper iron provisions

Basic Frame\$1,345.00

DELUXE FRAME, *Includes the basic frame features plus:*

1. Chevy V-8 motor mounts welded to frame
2. Double K-member crossmember for frame rigidity
3. All body mount, running board, and fender brace holes pre-drilled and threaded
4. Vega steering box mount
5. Brake pedal assembly
6. Frame stepped in the rear, 2-1/2"

Deluxe Frame\$2,600.00

MODEL "A" CHASSIS *with independent front suspension*

1. Frame stepped (narrowed) at rear for tire clearance
2. Motor mounts and K-member crossmember
3. Brake pedal- power or manual
4. Heids Superide Independent front suspension
5. 9" Ford rear housing with axles and rebuilt center section
6. Rear four bar suspension with coil-overs and panhard bar
7. Rear drum brakes (10 x 2.5")

Chassis with IFS\$9,450.00

MODEL "A" CHASSIS *with straight front axle*

1. Frame stepped (narrowed) at rear for tire clearance
2. Motor mounts and "K" member crossmember
3. Brake pedal- power or manual
4. Dropped axle, 4-bar or hairpins, Vega cross steering, panhard bar
5. 9" Ford rear housing, axles and rebuilt center section
6. Rear 4-bar suspension with coil-overs and panhard bar
7. Front discs with GM calipers, Rear drum brakes (10 x 2.5")

Chassis with straight front axle\$8,500.00

Model "A" CHASSIS *Options*

- a. Brake booster and master cylinder \$220.00
- b. Super-Stopper front brake upgrade for dropped axle . \$995.00
- c. Rear brake upgrade
 - Wilwood discs with parking brake \$500.00
 - Wilwood discs without parking brake \$400.00
- d. Brake and fuel line package \$750.00
- e. Chassis painted \$1,500.00
- f. Front sway bar \$245.00
- g. Rear sway bar \$275.00
- h. Tru-Trac differential \$550.00
- i. 32 style fuel tank kit. \$695.00



1928-1931 Ford Frame Packages

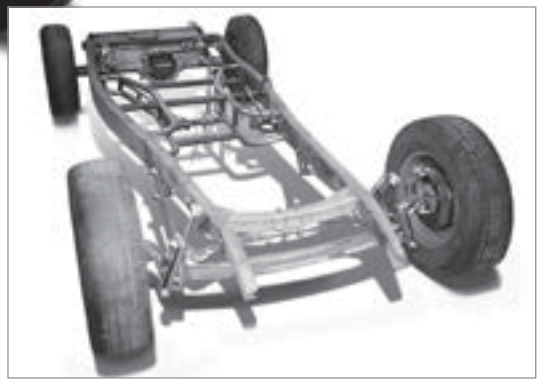
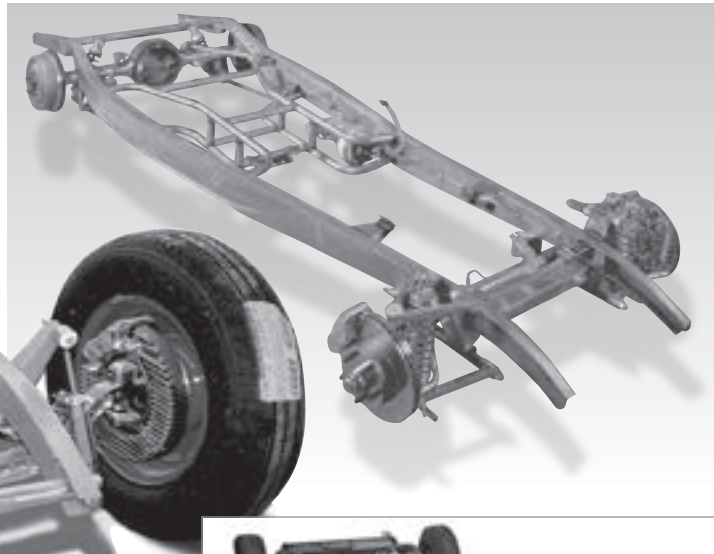

COMPLETE CHASSIS
 Starting at **\$10,495.00 with IFS**
\$8,450.00 with Solid Front Axle

1932 FORD NEW REPRODUCTION FRAMES AND CHASSIS

BASIC FRAME, *Standard Features:*

1. Precision jig welded to insure proper alignment
2. All welds are heliarc to insure super strong joints
3. Deuce Factory frame rails
4. 3/16" thick die formed front crossmember
5. Boxed in all necessary places with 3/16" plate
6. 1-1/4" and 1-1/2" tubing center crossmembers and braces
7. Engine and transmission mounts (small block Chevy or Ford)
8. Rear crossmember set up for Eliminator coil-over shocks
9. Front and rear spreader bars

Frame Rails \$995.00

Basic Frame \$4,995.00

Basic Frame (using customers stock rails) \$4,095.00

(Any repair that original rails require will cost extra)

As with all HEINZMAN STREET ROD products, any part or any stage of completion is available.

1932 CHASSIS with *Independent front suspension*

1. Boxed frame with tubular "X" member and "C" notched for rear axle clearance, front and rear spreader bars, frame primed
2. Engine mounts, spreader bars, brake pedal (power or manual)
3. Heidts Superide Independent front suspension
4. 9" Ford rear housing with axles and rebuilt center section
5. Rear 4-bar suspension (triangulated link or parallel) with coil-overs and panhard bar
6. Rear drum brakes (10 x 2.5")

Chassis with IFS \$10,495.00

1932 CHASSIS with *straight front axle*

1. Boxed frame with tubular "X" member and "C" notched for rear axle clearance, front and rear spreader bars, frame primed
2. Engine mounts, spreader bars, brake pedal (power or manual)
3. Dropped axle, 4-bar or hairpins, Vega cross steering, panhard bar
4. 9" Ford rear housing with axles and rebuilt center section
5. Rear 4-bar suspension (triangulated link or parallel) with coil-overs and panhard bar
6. Front discs with GM calipers, Rear drum brakes (10 x 2.5")

Chassis with straight front axle \$9,950.00

1932 CHASSIS *Options*

- a. Super-Stopper front brake upgrade for dropped axle . \$895.00
- b. Rear brake upgrade
 - Wilwood discs with parking brake \$500.00
 - Wilwood discs without parking brake \$400.00
- c. Brake and fuel line package \$750.00
- d. Chassis painted. \$1,500.00
- e. Front sway bar (IFS) \$275.00
- f. Rear sway bar \$279.00
- g. Tru-Trac differential \$550.00
- h. Polished stainless steel parts (4-bar, shackles, shocks tie rods, etc) \$690.00
- i. Billet rack & pinion \$599.00
- j. Brake booster and master cylinder \$220.00
- k. Stainless steel A-arm package \$1500.00
- l. Front sway bar (solid axle) \$249.00
- m. Stainless steel tie rod ends (IFS) \$78.00
- n. Stainless steel spreader bars \$75.00

Call 402.886.2275 or click: www.heinzmanstreetrods.com

1932 Ford Frame Packages



**COMPLETE CHASSIS
with IFS** Starting at **\$9,553.00**

1933-34 FORD NEW REPRODUCTION FRAMES

BASIC FRAME, *Standard features:*

1. Fully box frame rails built in super accurate jig.
2. All mounting holes have nuts installed.
3. Universal trans mounts accepts
4. Several engine and trans combinations.
5. 1-1/2" dia. tubular x-member.

BASE FRAME WITH MOTOR MOUNTS \$4,995.00

Note: We can also use your good original frame.
Call for information.

1933-34 BASE CHASSIS *with Independent front suspension*

1. Reproduction frame, boxed with tubular "X" member as listed above, primed
2. Engine mounts
3. Heids Mustang II crossmember and tubular control arms
4. Manual rack and pinion steering
5. 8" Ford rear- used with drum brakes
6. Chassis Engineering rear leaf spring kit
7. Front and rear sway bars

1933-34 Chassis with IFS \$9,550.00

**1933-34 Chassis with IFS and NEW 9" Ford rear with
drum brakes and choice of gear ratios \$10,450.00**

1933-34 CHASSIS *Options*

- a. Brake pedal, booster and master cylinder **\$425.00**
- b. GM metric front brake calipers and brackets **\$185.00**
- c. Wilwood 4 piston front calipers and brackets **\$400.00**
- d. Brake and fuel line package **\$750.00**
- e. Rear Brake Upgrade
 - Wilwood discs with parking brake **\$500.00**
 - Wilwood discs without parking brake **\$400.00**
- f. Rear 4-bar suspension with coil-overs **\$650.00**
- g. Chassis painted (Du Pont Imron) **\$1,500.00**
- h. Heidt's Superide front suspension **\$1,650.00**
- i. Stainless steel gas tank **\$1,050.00**
- j. 9" Ford Tru-Track differential **\$550.00**

1934 FORD SPECIFICATIONS

WHEELBASE: 112" (all passenger and commercial)

BB TRUCK: 131 1/2" and 157"

FUEL CAPACITY: 11 gal.

COOLING CAPACITY: 22 qts.

APPROX WEIGHT: 2675 lbs.

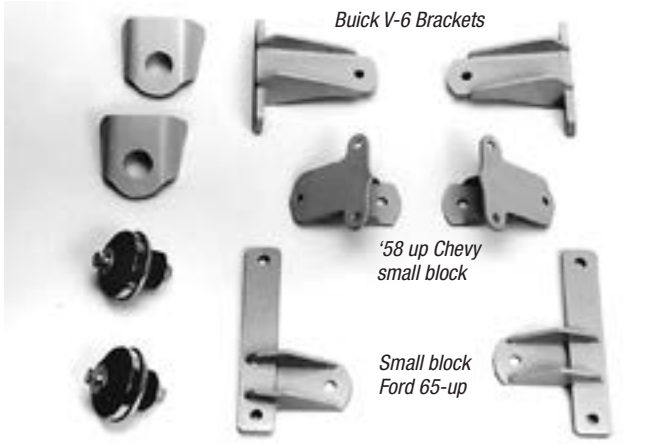

1928-31 FORD ENGINE AND TRANSMISSION MOUNTS

Kits included weld on frame adapters (frame must be boxed), Chassis Engineering engine side mounts, through bolt cushion set, and instructions.

CP-2107	Chevy Small Blocks 58-up	\$159.00
CP-2605	Buick V-6	\$159.00
CP-2205	Ford V-8	\$167.00
CP-2805	Ford Flathead V-8	\$95.00
	Transmission Mount	\$75.00
C.E. Double K-Crossmember and trans mount		\$155.00
SS-0011	Motor Mount Cushions	\$45.00



1932 FORD ENGINE MOUNT KITS

CP-2107	Chevy Small Blocks 58-up	\$143.00
CP-2607	Buick V-6	\$167.00
CP-2207	Ford V-8	\$167.00

1933-34 FORD ENGINE MOUNTS KITS

CP-2104	Chevy Small Blocks 58-up	\$159.00
CP-2604	Buick V-6	\$159.00
CP-2204	Ford V-8	\$167.00
CP-2808	Ford Flathead V-8	\$95.55



1932-34 X-MEMBER & TRANSMISSION MOUNTING KIT

Heavy steel formed X-member gives needed rigidity for open or closed cars. Works with most repro or original frames and engine/trans combos. Requires a flat floor pan.

AT-2032	X-Member	\$349.00
ES-2132	Chevrolet Turbo 350 trans mount.	\$180.00



MODEL "A" FRONT CROSSMEMBER

Lowers your '32 chassis 1-1/2". Die formed from 3/16" steel. Also for Model A.

3250	\$95.00
------	-------	---------

NOTE: Center and rear crossmembers are also available.



1932 FORD BOXING PLATES

3/16" thick steel. Front plate extends from front crossmember to beyond firewall. Rear plate covers complete kick-up.

Front or Rear, Pair	\$87.00
---------------------------	---------

1933-34 FRAME BOXING PLATES

3/16" thick, extends from front crossmember to X-member. Two plates per kit-left and right.

AR-2097	Front	pair \$81.00
AR-2098	Rear	pair \$93.00



1933-34 CENTER X-MEMBER MODIFICATION AND TRANSMISSION MOUNT KIT

Replaces center part of cross-member. No cutting on X rails. Uses some old rivet holes for line up. Fits all GM transmissions except 400. Can easily be modified for others. Bolt on unit gives 360° strength, a proven concept. Bolts and instructions included.

ES-2130	\$220.00
---------	-------	----------



1928-1934 Ford Frame Parts

1928-1934 Ford Front Suspension Parts



1932 SPREADER BARS

Made to exact dimensions of the originals and are a must for setting up your chassis.

3209	Front	\$42.00
3210	Rear	\$53.00
<i>Polished Stainless Steel</i>		
3362	Front	\$90.00
3363	Rear	\$120.00



VINTAGE CHASSIS FORGED I-BEAM & TUBE AXLES

1928-48 Ford 4" drop axle, 47" wide. Uses 1937-48 Ford spindle. State 2" or 2-1/4" perch boss. Forged axles are several times stronger than cast type. Narrower width is ideal for Ford. Requires special main leaf. 1-1/2" narrower between perches.

AU-2107	Forged Axle, 47", 2-1/4" perch	\$395.00
AU-2105	Tube Axle, 46, 47, 48.5", 2" perch	\$395.00



CHASSIS ENGINEERING FORGED SPINDLES

Precision replacement for 1937 to 41 Ford spindle. . . . \$250.00
 Complete with king pins fitted

Also Available machined for GM Rotors

Spindle Nuts



KING PIN SETS

3269	1937 to 41 Ford	\$60.95
3279	1942 to 48 Ford	\$60.95

POLYPROPYLENE

Using polypropylene between spring leaves reduces friction and wear, allowing the spring to move freely for a better ride.

AU-2066	1.75"	\$12.00
AU-2067	2.00"	\$14.00
AU-2068	2.25"	\$16.00

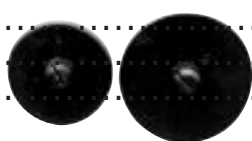

FORGED SPINDLE ARMS

Double end on right. For use with dropped axles and cross steering.

1108	1928-34 Ford	pair \$130.00
-------------	---------------------------	----------------------

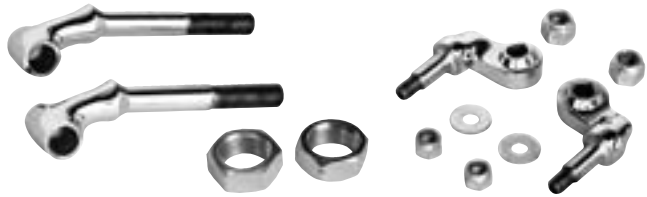

SPRING PERCHES AND LOWER SHOCK MOUNTS

3219P	Stainless perches	\$85.00
3218P	Lower shock mount	\$85.00
Unpolished S.S. perches or lower shock mounts		\$110.00
00000	Perch Jam Nuts	\$120.00

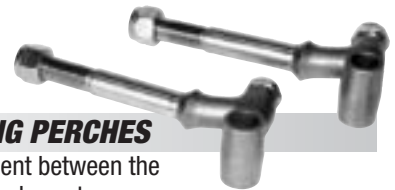

SELF-ALIGNING SPRING PERCHES

Allows for the perfect alignment between the spring and the desired front axle castor.

1928-34 Ford, plain SS	pair \$165.00
1928-34 Ford, polished SS	pair \$199.00



EASY RIDER FRONT SPRING

Chassis Engineering springs feature leaf ends that are rolled thin and diamond cut for traditional Street Rod styling. Special hidden sliders are installed at the end of each leaf and are locked in place so they can't work out. Nothing shows to mar the smooth lines. This is the best appearing and performing early Ford spring available.

FS 2834	\$169.00	
FS2834M	Reversed eye main leaf	\$75.00



FRONT U-BOLTS & SPRING PAD

U-Bolts with lock nuts and spring pads	set \$47.95
Stainless Steel U-bolt and pad set	set \$69.95



SHACKLES

STANDARD

- 3221F Front (specify 1-3/4" or 2") \$45.00
- 3221R Rear 2-1/4" \$45.00

STAINLESS FRONT

- 3355 Polished 1-3/4" \$70.00



FRONT SHOCK KITS

Our tube front shock kits are designed to be functional for the weight of the average Street Rod and to compliment the front end of your car. The kit includes shock absorbers, lower shock mounts, upper frame brackets and all necessary bolts, nuts & washers.

- 3222W Model A and '32 weld-on \$180.00
- 3222B Model A and '32 bolt-on \$190.00
- 3223B 1934 bolt-on \$190.00

Above available with Chrome Shocks and Polished Stainless Lower Shock Mounts \$255.00

- 3300 Tube shocks only pair \$60.00
- 3300A Tube shocks only-chrome pair \$95.00

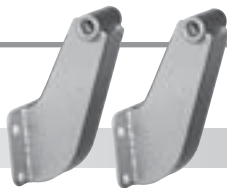

SHOCK FRAME BRACKETS

Top quality die stamped brackets

- 3324 Model A and 32 Weld-on \$39.00
- 3325 Model A and 32 Bolt-on \$45.00
- 3325A 1934 Bolt-on \$45.00



STEERING U-JOINTS AND SHAFTS

Forged steel with roller bearings make this the best joint available. Specify Vega, Chevy manual, Chevy power, Mustang early, Pinto manual, Pinto power.

- U-joints \$90.00
- Spine or DD shafts \$40.00



FORD TIE ROD ENDS (with jam nuts)

- 3237R Right hand \$30.00
- 3237L Left hand \$30.00
- Stainless steel tie rod ends ... \$45.00



TIE ROD & DRAG LINK

Made from 7/8" seamless tube with for tie rod end and jam nuts. Made to fit Super Bell Axle or specify center to center length.

- 2180 Tie rod or drag link \$96.00
- Polished S/S tie rod assembly \$212.00



VEGA STEERING ADAPTER

The recommended steering box for 1928 to 34 Fords. The bracket must be welded to a boxed frame.

- 1019 \$50.00
- AU-2131 GM 140 vega steering box \$365.00
- 1020 Pitman arm \$85.95

For complete steering hook-up kits- see page 00



UNI-STEER RACK AND PINION STEERING

Cross Steer was engineered specifically to work with 1928-1934 solid axle Fords and has no bump-steer. It is designed to replace the typical Vega steering box and bolts to the Vega bracket and includes the steering shaft. Also available for new builds w/o shaft.

- 8000460-01 1928-32 new build (no shaft kit) \$450.00
- 8000470-01 1928-32 cross steer retrofit kit (includes shaft kit) \$485.00
- 8000680 1933-34 new build (no shaft kit) \$425.00
- 8000510 1935-40 cross steer retrofit kit \$450.00



1928-1934 Ford Front Suspension Parts

1928-34 FORD Hot Rod Suspension Parts

1928-1934 Ford Front Suspension Parts



FRONT 4-BAR or HAIR PIN KITS

Standard Cross Steering

- 3282C Model "A" \$395.00
- 3282A 1932- 34..... \$395.00
- 3282X Extra Long \$395.00

Polished Stainless Cross Steering

- 3282CP Model "A" \$595.00
- 3282AP 1932- 34..... \$595.00
- 3282XP Extra Long \$605.00



STAINLESS STEEL GT BAT WINGS for 4-BAR SUSPENSION

- 3299GT Unpolished..... pair \$125.00
- 3299GTP Polished pair \$155.00

CUSTOM STAINLESS 4-BAR BOLTS

- 3284 \$95.00



STAINLESS 4-BAR ADJUSTERS

- 3293 Straight 5/8-18 adjuster each \$25.00
- 3293B Straight 3/4-16 adjuster each \$25.00
- 3294 11 angled 5/8-18 adjuster each \$25.00
- 3295 7 angled 5/8-18 adjuster each \$25.00

(All part numbers include Jam Nuts) Add \$4.00 for polished

4-BAR BUSHING SLEEVES

For urethane "90" bushings

- 3259A Front 4-Bar sleeves..... each \$4.50
- 3312A Rear 4-Bar sleeves each \$4.99



URETHANE "90" BUSHINGS

- 3259 B Front 4-bar urethane 90 bushings \$5.50
- 3312B Rear 4-bar urethane 90 bushings \$6.95

STAINLESS WASHERS

- 3278A Front 4-Bar polished 1/2", 9/16" & 5/8" ... \$3.50

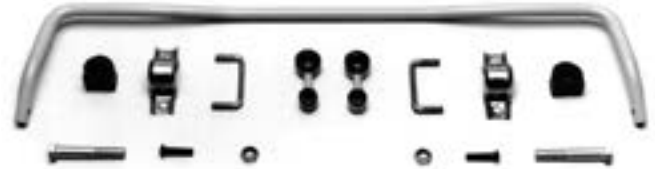

SOLID AXLE FRONT SWAY BAR KIT

Completely bolt-on unit mounts to the 4-Bar batwings. Cures many steering and handling problems. Please specify type of axle and bat-wing to 4-bar bolt.

- 8065 1928-34 Ford front. \$195.00



1933-34

MUSTANG II INDEPENDENT FRONT SUSPENSION

HEIDT'S MUSTANG II IFS Crossmember Kits retain all factory dimensions and locations, so you get all the benefit of Ford engineering in your front end. The kit includes upper fender brace adapter brackets and radiator mount tabs.

- PX101 1933-34 crossmember \$575.00
- #SB3334PM Front sway bar kit \$175.00



1937-48 SPINDLE ECI DISC BRAKE KIT

ECI's Disc Brake kits bolt-on to stock or reproduction 1937-48 spindles. Kits include: GM full size car calipers/pads, 11 inch rotors with Ford or GM bolt pattern, bearings/adapters, seals, hardware, brackets and instructions

- EC-701CK GM 4-3/4" bolt circle. \$425.00
- EC-709CK Ford 4-1/2" bolt circle. \$425.00
- EC-730CK Ford 5-1/2" bolt circle (use F150 rotors). \$425.00 (see page 62 for complete listing)



HEIDTS "SUPER RIDE" INDEPENDENT FRONT SUSPENSION KIT

For Model A, 1932 Ford, & 1933-34 Ford

Independent front suspension gives you twice the ride of a new 4 link dropped axle at a comparable cost. Kit includes main crossmember, dropped spindles, adjustable control arms, Wilwood calipers, 11"

rotors, adjustable coil overs, new rack and pinion steering, stainless adjusters with urethane bushings, OEM style factory ball joints and tie rod ends for durability.

..... \$4,685.00
 (Add \$495.00 for stainless control arms)

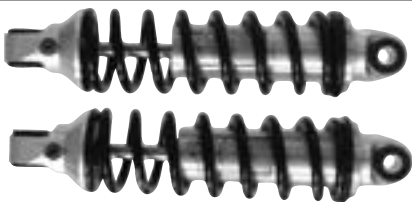

COIL OVER SHOCK ASSEMBLIES -QA1

Coil Over Shocks are available with plain or polished aluminum shock bodies. Spring height adjustment is by a threaded spring seat and locking ring. Shock rate is adjustable using 6 position adjustment knob.

QA1 Coil Over Specifications:

US-304	12-5/8" Extended	9-5/8" Compressed
US-402	14" Extended	10" Compressed
US-404	15" Extended	11" Compressed
US-502	17" Extended	12" Compressed

Spring Rates are available in 150-700# in 50# increments for tuning

US-304	QA1 Coil overs - Ultra-Ride, Front \$525.00
US-402	QA1 Coil overs - Ultra-Ride, Front \$525.00
US-404	QA1 Coil overs - Ultra-Ride, Rear \$525.00
US-502	QA1 Coil overs - Ultra-Ride, Rear \$525.00
	1/2 bearing ends add \$20.00

(Chrome Springs Available)

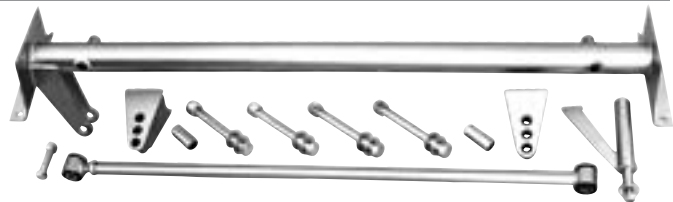

REAR COIL OVER SHOCK SUSPENSION KIT

- Tube crossmember, boxing plates, upper shock mounts
- Panhard bar with axle and frame brackets
- Lower shock mounts with 3 vertical positions to adjust ride height
- Works with Viper coil overs or others

2013	1928-31 Ford \$175.00
3013	1932 Ford \$403.00
4013	1933-34 Ford \$403.00
5013	1935-48 Ford \$403.00



1928-31 REAR 4-BAR KITS

Four high strength steel bars give positive control to the rear end. Threaded adjusters are Stainless with Urethane bushings. Kit comes with frame brackets, 4 bars, axle brackets, bolts and instructions.

2017	1928-31 Ford, has lower coil over mounts built in \$445.00
	Polished S/S add \$200.00



1928-31 REAR UPPER COIL-OVER SHOCK MOUNT

Weld to stock crossmember or replacement tube. Also bolts bumper irons in place.

1090	1928-31 FORD (upper mount) pair \$90.00
------	---------------------------------	---------------

Call 402.886.2275 or click: www.heinzmanstreetrods.com



PANHARD ROD

Fits C.E. or boxed original frames. Adjustable bar with bolt on rear end bracket. Fits Ford 8" rear ends (Maverick, Mustang, etc.)

2015 \$112.00

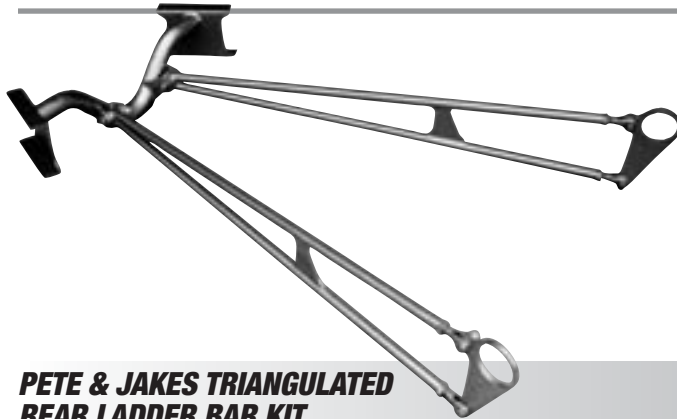

PETE & JAKES TRIANGULATED REAR LADDER BAR KIT

- Mounts rear end into Model A's through 1948 Fords
- Pre-welded crossmember welds to x-member or boxing plates
- Urethane bushings at front center pivot
- Adjustable clevis at rear • Ultimate in strength and traction

(Specify rear axle housing diameter)

2011 1928-'31 Model A \$475.00
 3011 1932 Ford \$475.00
 4011 1933-'34 Ford \$475.00

DRAG RACING VERSION with double gussets for extra strength

2011 DR 1928-31 Model A \$540.00
 3011 DR 1932 Ford \$540.00
 4011 DR 1933-34 Ford \$540.00



REAR END MOUNTING KIT

Completely bolt on kit also reinforces rear of frame. No welding on car or rear end required. Uses Maverick or Mustang rear, others fit by moving spring pads. Smooths a normally choppy ride. *Kit includes:* right and left front and rear brackets, shackles, upper shock mounts, lower shock mounts, spring retainers, U bolts, springs, bolts and instructions.

AS-2012 1933-34 \$1,370.00



REAR TRIANGULATED 4-BAR KIT

The Deuce Factory's rear triangulated 4-bar kit is an ideal way to mount your rear end. The design is very similar to that used by General Motors. All brackets are die stamped in 3/16" steel. The tubing used is 1 by .156" wall and equipped with urethane bushing available in steel or polished stainless steel.

Standard:

2018 Model A \$445.00
 3018 1932-34 \$445.00

Polished Stainless/Chrome:

3364P Model A \$550.00
 3296P 1932-34 \$550.00



REAR PARALLEL 4-BAR KITS

The Parallel 4-bar kit is very easy to install and is a good choice for many installations. It uses 1 x .156" tube bars with 3/4" stainless adjusters and urethane bushing, chassis mounting brackets, multi-position coil-over axle brackets and hardware. **NOTE:** These kits require the use of a panhard Rod.

2017 Model A \$455.00
 3017 1932 Ford \$445.00
 4017RP 1933-34 \$445.00
 Chrome, add \$120.00



REAR STABILIZER BAR KIT

Most street rods today are utilizing coil spring suspension which gives a softer ride but will tend to have more roll in the chassis. This anti-roll bar will greatly increase the chassis roll stiffness. The bar is 3/4" dia. and 27" long with 48 splines on the ends of the bar to correspond with the arms. The hole to hole arm length is 8". The bar is mounted to the rear cross member with aluminum pillow blocks and the arms mount to the rear housing with rod end links.

3298 1932-34 \$325.00
 8098 1928-34 \$265.00

1928-1934 Ford Rear Suspension Parts

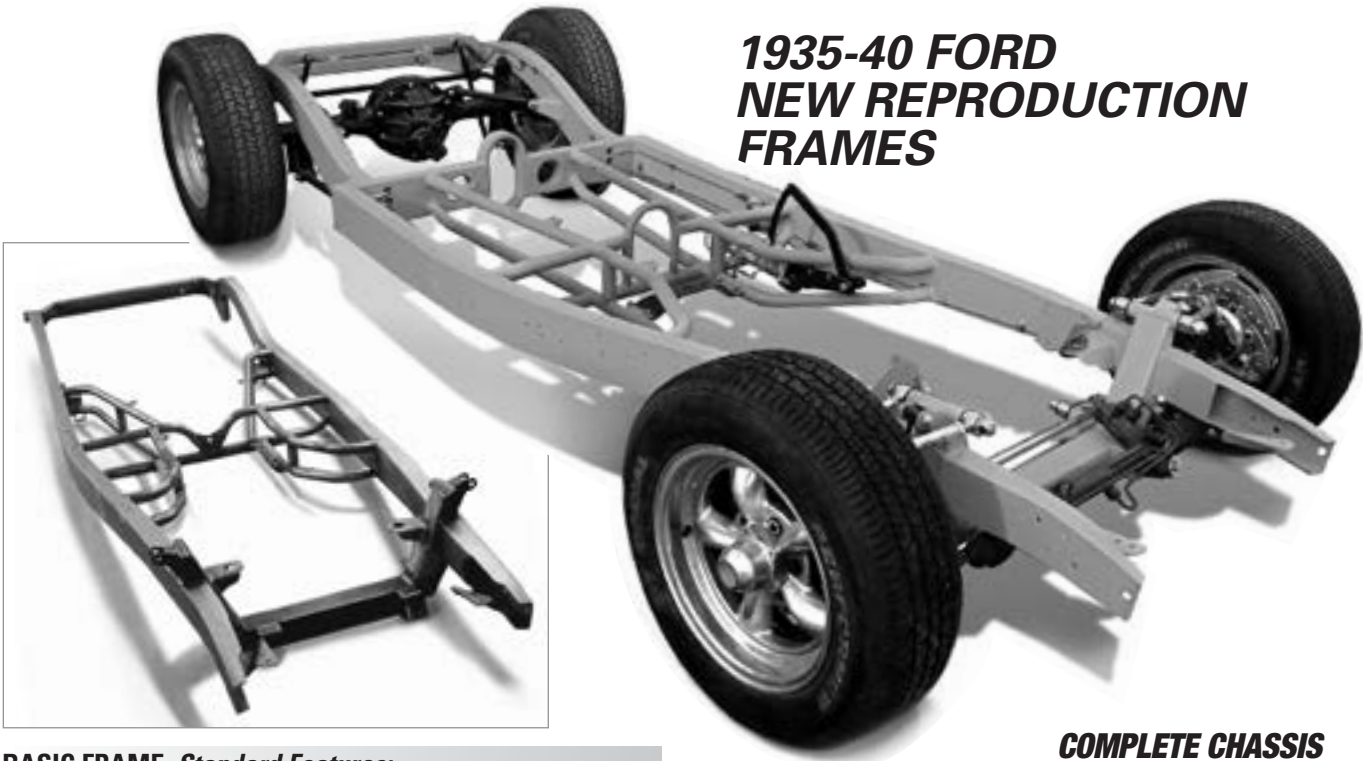

1935-40 FORD NEW REPRODUCTION FRAMES

**COMPLETE CHASSIS
with IFS Starting at \$10,450.00**

BARE FRAME with IFS Starting at \$5,500.00

BASIC FRAME, *Standard Features:*

- 10 gauge rails built in a super accurate jig
- Fully boxed new rails for strength and appearance
- All mounting holes have weld nuts installed
- Universal transmission mount accepts several motor transmission combinations
- Tubular X-member is 1-1/2 diameter x .120" wall tubing welded at 12 points
- Body side mounts installed on outside of frame rails
- Mustang II crossmember installed (stock type springs)

Base Price\$5,500.00

Note: We can also use your original frame – please see page 12

The basic chassis can be configured in many ways:

- Several engine and transmission choices
- Several rear suspension choices: leaf spring, coil overs, 4-link. Some parts available in stainless steel
- Mustang II, Heidt's Superide II, or dropped straight axle front suspension available

1935-40 BASE CHASSIS *with Independent front suspension*

1. Reproduction frame with all the basic frame features listed above with primer coat
2. Engine mounts
3. Heidts Mustang II crossmember, tubular control arms and 11" front brake rotors
4. Manual rack and pinion steering
5. 8" Ford rear complete (used) with drum brakes
6. Chassis Engineering rear leaf spring kit
7. Front and rear sway bars

1935-40 Base Chassis with IFS\$9,450.00

1935-40 Base Chassis with IFS and NEW 9" Ford rear with drum brakes and choice of gear ratios\$10,450.00

1935-40 BASE CHASSIS *Options*

- | | |
|---|-------------------|
| a. Brake pedal, booster and master cylinder | \$425.00 |
| b. GM metric front brake calipers and brackets. | \$185.00 |
| c. Wilwood 4 piston front calipers and brackets | \$500.00 |
| d. Brake and fuel line package | \$750.00 |
| e. Power Steering | \$200.00 |
| f. Rear Brake Upgrade | |
| Wilwood discs with parking brake | \$500.00 |
| Wilwood discs without parking brake | \$400.00 |
| g. Rear 4-bar suspension with coil-overs | \$650.00 |
| h. Chassis painted (Du Pont Imron) | \$1,500.00 |
| i. Heidts Superide II front suspension with coil-over shocks,
Wilwood Brakes | \$1,750.00 |
| j. Traction Lok differential upgrade. | \$550.00 |
| k. TRU-TRAC differential upgrade | \$750.00 |
| l. Polished stainless steel A-arm package | \$1,600.00 |



1935-1940 Frame Packages



COMPLETE CHASSIS
with IFS Starting at **\$9,450.00**
exchange

1935-40 AND 1941-48 FRAME EXCHANGE PROGRAM

**Trade in your original frame for
a ready-to-roll street rod chassis!**

The basic package includes:

- An original 1935-40 or 1941-48 Ford frame sandblasted, repaired and primed
- Overdrive trans X-member modification
- Heidt's Mustang crossmember kit and tubular A-arms
- Mustang II front suspension. Includes: new 5-bolt rotors, shocks, springs, spindles, and a manual rack & pinion steering gear
- Small block Chevy or small block Ford front & rear motor mounts
- 8" Ford rear end-used (9" rear available)
- Chassis Engineering parallel leaf spring rear suspension
- Front and rear sway bars

1935-40/1941-48 exchange \$9,450.00

**Chassis are also available outright
without a frame trade-in Core Charge \$500.00**

**Above chassis with NEW 9" Ford rear, drum brakes
and choice of gear ratios \$ 9,955.00**

1935-40/1941-48 EXCHANGE CHASSIS Options

- a. Heidts Superide II front suspension with coil-overs, tube A-arms, Wilwood disc brakes **\$1,750.00**
- b. Rear 4-bar suspension with coil-overs **\$650.00**
- c. Brake pedal, booster and master cylinder **\$425.00**
- d. GM metric front brake calipers and brackets. **\$185.00**
- e. Wilwood 4 piston front calipers and brackets **\$450.00**
- f. Brake and fuel line package **\$750.75**
- g. Power Steering **\$200.00**
- h. Rear Brake Upgrade
 - Wilwood discs with parking brake **\$500.00**
 - Wilwood discs without parking brake **\$400.00**
- h, Chassis painted/ body work (Du Pont Imron). **\$1,500.00**
- k. TRU-TRAC differential upgrade **\$550.00**
- l. Polished stainless steel A-arm package **\$1650.00**

ADDITIONAL OPTIONS

- Narrowed 9" Ford Housing with axles **\$895.00**
- Complete brake-fuel system w/ power booster master cylinder **\$1,050.00**
- Gas tank -poly or coated steel **\$230.00**
- Gas tank-stainless steel **\$950.00**
- EFI In-tank Pump **\$300.00**
- 9" Ford gear case (rebuilt) any ratio **\$1,400.00**



1935-1948 Frame Exchange

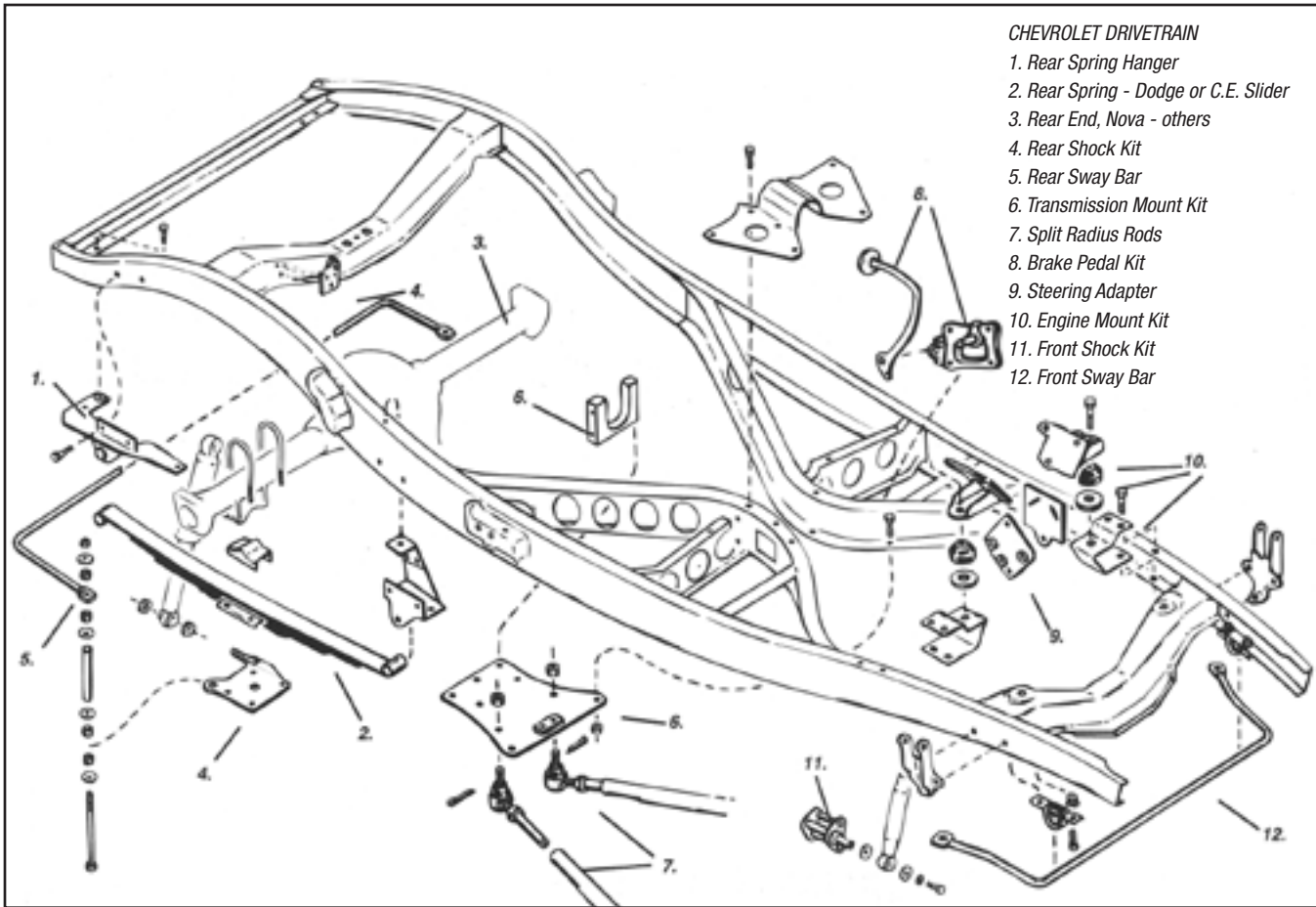

- CHEVROLET DRIVETRAIN**
1. Rear Spring Hanger
 2. Rear Spring - Dodge or C.E. Slider
 3. Rear End, Nova - others
 4. Rear Shock Kit
 5. Rear Sway Bar
 6. Transmission Mount Kit
 7. Split Radius Rods
 8. Brake Pedal Kit
 9. Steering Adapter
 10. Engine Mount Kit
 11. Front Shock Kit
 12. Front Sway Bar

ENGINE MOUNTING KITS

SMALL BLOCK FORD ENGINE MOUNTING KIT-BOLT ON

Includes bolt on frame adapters, frame corner braces, C.E. engine side mounts, thru bolt cushion set, bolts and instructions.

- CP-2203 Bolt on kit (solid axle)..... \$195.00
- CP-2203PM Bolt on kit (Pinto-Mustang IFS) \$195.00

SMALL BLOCK FORD ENGINE MOUNTING KIT-WELD-ON

Includes weld on frame adapters, C.E. engine side mounts, thru bolt cushion set, bolts and instructions. Frame must be boxed to use. Generally used with Pinto-Mustang IFS.

- CP-2203G Weld on kit \$125.00



CENTER X-MEMBER MODIFICATION TRANSMISSION MOUNTING KIT

Uses original side bracing and full 360 degree design for the strongest support possible. Completely bolt on. The only kit that retains X-member strength. Bolts and directions included. For S.B. Chevy, but other engine and transmissions will work. Kits for split wishbones added have mount welded to bottom plate. These come with all parts needed. Fits TURBO 350, Powerglide, Manual 3 and 4 speeds.

- ES-2162 1935-36 \$275.00
- ES-2163 1935-36 w/wishbone kit..... \$489.00
- ES-2167 1937-40 \$275.00
- ES-2168 1937-40 w/wishbone kit..... \$489.00

SMALL BLOCK CHEVY ENGINE MOUNTING KIT

For small block Chevy, includes bolt on frame adapters, C.E. engine side mounts, thru bolt cushion set, bolts & instructions. C.E. mounts eliminate frame cracking caused by the "wedge action" of stock Chevy mounts.

- CP-2101 Bolt-in kit \$201.00
- CP-2101G Weld-in kit \$125.00
- SS-0011 Mount Cushion \$45.00

OVERDRIVE TRANSMISSIONS

For Turbo 700R4. Use with IFS only. For experienced builders.

- ES-21650D 1935-36 Overdrive kit. . . . \$770.00
- ES-21670D 1937-40 Overdrive kit. . . . \$770.00



Call 402.886.2275 or click: www.heinzmanstreetrods.com

1935-1940 Frame and Suspension Parts

1935-1940 Frame and Suspension Parts



REPLACEMENT X-MEMBER KIT

Formed channel X-member gives excellent rigidity for fiberglass or steel bodies. Ideal for open cars but works well under closed cars too. Fits stock or repro frames. Kits have room for most engine combinations. Will fit under stock bodies but is not an exact stock replacement. X-member is opened up for transmission clearance. The front of the X is angled. Floor pan will bolt down like stock. Two side braces replace stock items, not included with kit. Requires a Chassis Engineering brake pedal. Note: recommended for experienced builders only.

- AT-2036 X-rails \$375.00
- ES2140 Center transmission mount, Chevy 350-etc. \$185.00
- ES-2141 Side braces from frame to Chassis Engineering X-member center. \$90.00



1935-40 BOXING PLATES

Boxing plates are 3/16" thick steel. Two plates per kit, R&L.

- AR-2280 Frt, stock frame, stock crossmember, . . pr \$81.00
- AR-2281 Frt, stock frame, Mustang II crossmember pr \$81.00
- AR-2284 Rear, stock frame pr \$95.00



FRONT CROSSMEMBER

Weld in replacement for the 1935-40 Fords. Clears fuel pump on the Chevrolet V8. For use with CE Easy Rider or original suspension.

- 5024 \$120.00



RADIATOR MOUNTS

State year of car. Use with our crossmembers on stock or repro frames. Stock crossmembers may need slight fitting.

- AU-2250A 1935-39 Std with stock crossmember . . pair \$98.00
- AU-2250B 1935-39 Std with stock crossmember . . pair \$98.00
- AU-2250C 1939 DLX-40 with stock crossmember pair \$98.00
- AU-2250D 1939 DLX.-40 with I. F. S. crossmember . . pair \$98.00



WISHBONE SPLITTING KIT

Bolts to X-member to spread wishbone as little as possible. Uses heavy duty 3/4" truck tie rod ends. Must be welded to wishbone. Bolts and instructions included.

- AS-2085 1935-48 \$199.00



BODY MOUNTS

These are replacements for those missing or rusted body mounts on the outside of the 1935-1940 Ford frame (weld on).

- AR-2060 Contains all 4 mounts \$160.00
- Front or rear per pair. \$90.00

BOLT ON BODY MOUNTS

- Front left or right each \$60.00
- Rear left or right each \$60.00



BOLT ON STEERING ADAPTER

This is an excellent change. Mounts GM steering gear, standard or power to 1935-48 Ford. Late column or original may be fitted. Bolts and instructions included.

- AS-2089 1935-36 \$81.00
- AS-2090 1937-40 \$79.00
- AS-2094 1941-48 \$79.00





BOLT ON STEERING ADAPTER with S.B. Ford engine

Intended for use only with engine swap CP-2203. Adapts Saginaw steering boxes, manual or power, to 1935-40 Ford with Ford engine. Late column or original may be fitted. One U-joint required. Bolts and instructions included.

AS-2095 Bolt on steering adapter \$93.00



MASTER CYLINDER ADAPTER

Bolts Mustang master cylinder to 1939-48 Ford (also 1935-38 using 1939-40 brake pedal assembly). Chevy master cylinder can be modified to work. Bolts included.

AS-2021 \$75.00



BRAKE PEDAL KIT

Bolt on brake pedal and mounting kit. Mounts Mustang master cylinder (Chevy cylinder can be modified to work). Bolts and instructions included.

AS-2040 1935-40 \$204.00



POWER BRAKE ADAPTER

Adapts Pinto power booster to stock 1939-1940 or Chassis Engineering pedal assembly. May need X-member alterations for clearance.

AS-2051 for stock 1939-1940 pedal \$100.00

AS-2052 for Chassis Engineering pedal \$100.00



POWER BRAKE BOOSTER- DUAL DIAPHRAGM

This 7 inch dual booster is an ideal size for most street rods

AS-2075 7 inch dual booster \$145.00

8531 8 inch dual booster \$145.00

MASTER CYLINDERS

Please give us details of your application when ordering master cylinders

AU-2036 Mustang 15/16" bore, manual brakes . . . \$89.00

AU-2037S Mustang 1" bore, manual brakes. \$89.00

AU-2037P Corvette 1" bore, power brakes only \$89.00

AU-2039 Corvette 1-1/8" bore, power brakes only \$129.00

AU-2041 Remote Fill 15/16" bore, power brakes only \$79.00

AU-2042 Remote Fill 1" bore, power brakes only. . \$79.00



1937-48 SPINDLE ECI DISC BRAKE KIT

ECI's Disc Brake kits bolt-on to stock or reproduction 1937-48 spindles. Kits include: GM full size car calipers/pads, 11 inch rotors with Ford or GM bolt pattern, bearings/adapters, seals, hardware, brackets and instructions

EC-701CK GM 4-3/4" bolt circle \$425.00

EC-709CK Ford 4-1/2" bolt circle \$425.00

EC-730CK Ford 5-1/2" bolt circle (uses F150 rotors) . \$425.00
(see page 62 for complete listing)



1935-1940 Brake and Suspension Parts

1935-1940 Front Suspension Parts



ON ALL AXLES, SPECIFY 2" OR 2 1/2" AXLE BOSS

DROPPED FRONT AXLES

Chassis Engineering forged I-Beam axle is 47" between King Pin centers and is narrower between perch bolts. Requires special main leaf. We recommend this axle when putting a dropped axle in a 1935-40 Ford. Use the 1937-40 wishbone because the 1935-36 is wider and will interfere with the tires when turning.

- AU-2107** Vintage I-Beam \$395.00
- Special main leaf..... \$75.00



EASY RIDER FRONT END KITS

All the pieces needed to lower the front end -make it handle and ride super too. This kit includes Easy rider spring, (with C.E. sliders, Front shock kit with shackles, Dropped axle, Anti sway bar, New perch bolts, Instructions. A big improvement in driving pleasure. When ordering state engine type and year of wishbone. NEW - Kit now includes forged dropped spindle arms.

- FK-35-40**\$1,350.00



CHASSIS ENGINEERING FORGED SPINDLES

These American made forged spindles fit Ford axles (new or reproduction 1928-48).

- 1104** 1937-41 Ford spindle \$250.00
- 1104F-K** Complete with king pins fitted..... \$315.00

Also Available machined for GM Rotors

- 1107** Spindle nuts..... \$15.00

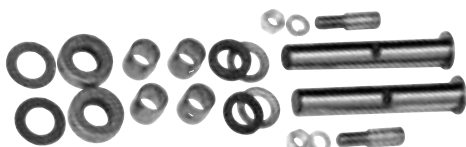

KING PIN SETS

- 3269** 1937-41 Ford \$60.95
- 3279** 1942-48 Ford \$60.95



FRONT SHOCK KIT 1935-40

Super-Strong—3 point mounting on upper bracket insures against breakage. Bolt on kit includes all necessary parts: 2 upper brackets, 2 shock absorbers, 2 combination spring shackles and lower shock mounts and all needed bolts and instructions.

WILL NOT WORK ON 1940 WITH STOCK SWAY BAR.

- AR-2037** Front shock kit..... \$195.00



PERCH BOLTS

New plain style fits 1935-1948 Ford. Extra long for bolt on lower sway bar mount.

- AR-2210** Perch bolts..... pair \$43.50
- AR-2212** Perch nut pair \$7.00



DROPPED STEERING ARMS

Fits 1935-1948 Fords. New C.E. forged arms are pre-bent to fit with dropped axles. Choice of Standard or Milled leg for disk brake adapter clearance. These are a deep drop design to clear 1935-48 wishbones. Bolts go through steering arms and use nuts instead of a blind threads that can loosen or strip.

- 1108D** \$130.00
- Milled for GM brake kit** \$140.00



FS-3540F

NEW 1935-40 STREET ROD SPRINGS

Chassis Engineering slider design uses hidden button sliders. Will not slip out like Teflon strips

- Front main leaf with reversed eyes** \$60.00
- FS-3540F** Front, reversed eye spring \$160.00
- RS-3540R** Rear spring for C.E. dual leaf kits pair \$502.00



RS-3540R



TIE ROD AND DRAG LINK

Ford tie rod ends use right and left hand thread for easy toe adjustment. AR-2180 tie rod has an extra tapered hole on the right to accept a drag link. Measure between the tapered holes and specify the length. Tie rod ends included.

- AR-2180 Drag Link, 36" or less \$100.00
- AR-2183 Tie Rod, more than 36" long..... \$110.00

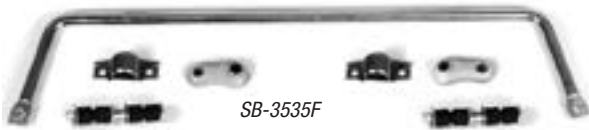

SB-3535F



SB-3535PM



SB-3540R



SB-3540RA



SB-3740F

FRONT AND REAR SWAY BARS

This is an excellent way to improve the handling and overall driveability of the top heavy Ford. Eliminates road sway. For best results use front and rear bars together. All needed linkage and mounting hardware furnished. An ideal addition for any car.

- SB-3536F **Front 1935-1936** Also fits 1937-1940 when using early style 1928-1936 axle or C.E. I beam... **\$185.00**
- SB-3740F **Front 1937-1940** Fits later axle (perch bolts are farther apart on 1937-1940 axle) **\$175.00**
- SB-3540FB **Front 1935-1940** Use with our 4-bar kit. State type of axle used. (See 4-bar kit)..... **\$175.00**
- SB-3540PM **Front 1935-1940** Fits Pinto-Mustang IFS kits (also fits many other P-M swaps) **\$175.00**
- SB-3540R **Rear 1935-1940** Fits C.E. rear end kit (can also be adapted to other cars) **\$205.00**
- SB-3540RA **Rear 1935-1940** Axle mounted, fits disc brakes rear like Lincoln Versailles. Very adaptable bar (will work on many other cars)..... **\$205.00**



SHACKLES

- 3321F **Standard, front, 2"** (pr) **\$40.00**
- AU2214 **1935-48 rear end kit** (pr) **\$60.00**



FRONT U-BOLTS SET

Fits 1935-48 front crossmember, stock or reproduction. u-bolts, nuts and bottom plate

- 1000 set **\$47.95**
- 1000C **Chrome**..... set **\$66.95**



HEIDTS SUPER RIDE II

Give your Fat Fendered Ford a smooth ride, good handling, and the ultimate look with Heidt's Superide II - *A complete front suspension kit which includes:* main crossmember, dropped spindles, adjustable tubular A-arms, adjustable coil over shocks with chrome springs, 11" disc brake vented rotors, billet calipers or GM calipers, front mounted rack and pinion steering, and factory ball joints & tie rod ends.

OPTIONS AVAILABLE: stainless steel, control arms, power rack and pinion, sway bar, polished shocks and polished calipers.

- BX202 **1935-40 Ford car/pick-up** **\$4,495.00**
- Polished stainless steel package** **\$1,650.00**



HEIDTS MUSTANG II WELD-ON CROSSMEMBER KIT

This kit mounts 1974-78 Mustang II or 74-80 Pinto/Bobcat front suspension to your 1935-40 Ford. Sets the car low and gives a nice ride! Available in Economy and Deluxe versions. Deluxe version has dressed welds *Kit includes:* lower crossmember, upper spring mounts, boxing plates, rear strut mounts, gussets and instructions (*Note: requires extensive welding*)

- PX202 **Crossmember Kit** **\$575.00**
- Crossmember kit complete with all parts.** . **\$2,200.00**

1935-1940 Front Suspension Parts



**BOLT-ON MUSTANG/PINTO I.F.S.
FEATURES ADJUSTABLE RIDE HEIGHT**

Fully bolt on crossmember uses Pinto or Mustang suspension components. No bump steer or other unpleasant surprises. Upper coil spring pads are adjustable for ride height, giving a 2-1/2" adjustment at the wheel, and excellent method of fine tuning final ride height to your taste. Center support rods add necessary strength to lower strut rod mount. Interlocking tabs between upper pods and crossmember prevent movement.

- IF-3540FP C.E. Mustang II crossmember. \$1,012.00
- weld-on installation option Add \$90.00
- Complete suspension component package. \$2,200.00



1935-40 LEAF SPRING REAR END MOUNTING KITS

Bolt-in kit adds reinforcing to rear of frame. No modifications of any kind to rear end. Uses two 61-69 Dodge pick-up springs. Kit includes front spring mount and rear spring mounts, bolts, general spring information & instructions. This kit uses 74-78 Ford Granada, 57-59 Ford or Ford Maverick rear end. 68-76 Nova rear end also fits but is too wide for many custom wheels. To use with other rear ends, correct spring pads can be welded on.

- AS-2014 1935-36 Car Only \$205.00
- AS-2016 1935-41 Pickup & 1937-40 Car \$205.00
- Complete Kit w/ Springs and all parts required. \$910.00
- AR-2070A Spacer kit w/ spring kit \$50.00
- RS-3540R Rear spring for C.E. dual leaf kits . . . pair \$502.00



REAR SHOCK KIT

Includes 2 lower spring retainer plates and shock mounts, 2 upper shock mounts, bolts and instructions. Use with our rear end kits only.

- AR-2038A 1935-40 \$230.00

REAR SHOCKS ONLY

- AU-2219 Special valving shock pair \$81.00
- AU-2219G Gas filled shock. pair \$81.00

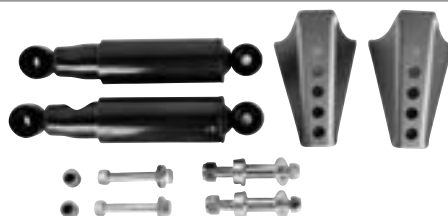

UNIVERSAL REAR SHOCK KIT

- Brackets have 4 vertical positions to dial-in shock travel
- Features Pete & Jakes Rod shocks
- Includes shock studs and upper brackets

- 1070 1935-40 \$115.00
- 1073 1941-48 \$139.00

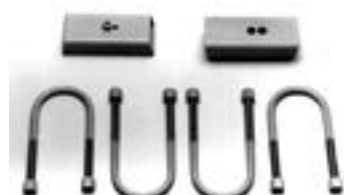

REAR AXLE SPRING PADS AND LOWERING BLOCKS

Stamped steel replacement axle pads for using when changing spring centers on late rear ends. For 2-1/2" springs.

- AU-2229 Axle Pads \$30.00
- U-Bolts set \$35.00
- AR-2070 Lowering blocks/U-bolt kit. pair \$75.00



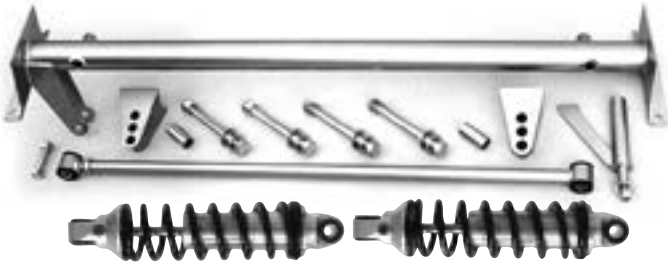

REAR COIL-OVER SUSPENSION KIT

This tube crossmember replaces the stock crossmember using existing rivet holes in the frame for location and easy installation. Includes boxing plates, upper shock mounts and panhard bar brackets welded to crossmember. Lower shock mounts have 3 positions to adjust ride height. Panhard bar axle bracket welds to back side of rear end housing.

5013	1935-40	\$405.00
658	US 404 Coil Overs	\$525.00
US502	QA-1 Coil Overs	\$525.00

(spring rates: 130#, 170#, 200#, 220#, 250#, 300#, 350#)



HEIDTS INDEPENDENT REAR SUSPENSION SYSTEM

The ultimate rear suspension from Heidt's. Uses 9" Ford 3rd member, Wilwood Inboard Brakes, Aldan coil-overs and standard widths from 55" to 62". Several options are available.

BR101 Complete hub to hub. \$10,975.00



TRIANGULATED LADDER BAR KIT

- Mounts rear end into 1935-40 Ford
- Pre-welded crossmember assembly welds into stock x-member
- Urethane bushings at front center pivot
- Adjustable clevis at rear
- Ultimate in strength and traction (specify housing diameter)

5011	1935-40	\$475.00
5011DR	Drag Race Version.	\$550.00



REAR PARALLEL 4-BAR KITS

The Parallel 4-Bar kit is very easy to install and is a good choice for many installations. It uses 1" x .156 tube bars with 3/4" stainless adjusters and urethane bushing, chassis mounting brackets, multi-position coil-over axle brackets and hardware. NOTE: These kits require the use of a panhard rod.

5017	1935 to 40 Ford: pain	\$455.00
5018	Universal tri-angulated kit	\$455.00
	Chrome	add \$120.00



1935-1940 Rear Suspension Parts

PLEASE SEE PAGE 12 FOR INFORMATION ON OUR 1941-48 FRAME EXCHANGE PROGRAM



ENGINE MOUNTING KIT

Mounts small block Chevy or small block Ford into 1941-48 Ford and includes bolt-on frame adapters, C.E. engine side mounts, thru bolt cushion set, bolts and instructions.

- CP-2102 S.B. Chevy engine mounts- 41-48 Ford . . \$165.00
- CP-2202 S.B. Ford engine mounts- 41-48 Ford . . . \$165.00
- Weld-on engine mounts- 41-48 Ford . . . \$143.00

FRONT SHOCK KIT

Super strong - 3 point mounting on upper bracket insures against breakage. Bolt-on kit includes all necessary parts: 2 upper brackets, 2 shock absorbers, 2 combination spring shackles and lower shock mounts plus all needed bolts and instructions. Clears stock sway bar.

- 6001 \$175.95

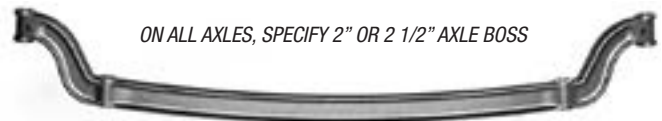

ON ALL AXLES, SPECIFY 2" OR 2 1/2" AXLE BOSS

DROPPED FRONT AXLES

Chassis Engineering forged I-Beam axle is 47" between king pin centers and is narrower between perch bolts. Requires special main leaf.

- AU-2107 Vintage I-Beam \$395.00



TRANSMISSION MOUNTING KITS

Bolt-on style kits fit all transmissions that measure 20-5/8" from engine to transmission mount holes (generally all except GM Turbo 400). Before ordering, determine which type frame you have. Check the box where the X-rails meet in the center. The "TYPE 1" X-member center is riveted to X-rails. The "TYPE 2" X-member center is a welded unit. Bolts and instructions included.

- ES-2178 Chevy trans. "TYPE 1" X-member \$175.00
- ES-2174 Chevy trans. "TYPE 2" X-member \$175.00
- ES-2278 Ford trans. "TYPE 1" X-member \$175.00
- ES-2274 Ford trans. "TYPE 2" X-member \$175.00
- All kits are available without Wishbone Mount \$90.00



CHASSIS ENGINEERING EASY RIDER FRONT END KIT

All the pieces needed to lower your car's front end and make it handle and ride super too. Requires a split wishbone kit or 4-bar system. Do it right with this engineered kit for a more enjoyable ride.

Kit Includes:

1. Easy Rider spring with anti-friction sliders.
2. Front shock kit especially designed for this kit
3. 48-1/2" dropped tube axle with forged ends welded to a tube center
4. Anti sway bar designed for this kit
5. New panhard rod
6. Forged dropped steering arms -specify "milled" for extra disk brake clearance
7. New perch bolts and nuts
8. Bolts and instructions

Note : Some of the above parts are not available separately. We do not usually recommend using tube axles with a split wishbone. However because of the small amount of separation at the wishbone end, and the use of a firm anti-sway bar to limit chassis roll, this complete kit will not cause any problems.

- FK-4148 1941 Ford \$1,350.00
 - FK-4148 1942-1948 Ford. \$1,350.00
- Specify if car is 1941 or is using a 4-bar

SMALL BLOCK FORD WISHBONE MOUNTING KIT

Ford C-4 automatics and manual transmissions do not need extra side clearance in the X-member area, but the wishbone does need to be dropped for bottom clearance. Wishbone does not need to be split with this bolt-in or weld in kit.

- AS-2083 Ford C-4 and manual trans- 41-48 Ford . . \$65.50



1941-1948 Ford Frame and Suspension



CHASSIS ENGINEERING FORGED SPINDLES

These American made forged spindles are fit Ford axles (new or reproduction 1928-48).

- AR-2020 Spindles \$250.00
- with bushings \$315.00

Also Available machined for GM Rotors

- AU-2134 Spindle Nuts..... \$ 20.00



KING PINS

Highest quality available. Sold in pairs

- AU-2138 1942-48 Ford \$61.70
- AU-2138S with stainless steel polished cap..... \$96.85
- AU-2135 Stainless steel king pin bearing..... \$32.00



TIE ROD AND DRAG LINK

Ford tie rod ends use right and left hand thread for easy toe adjustment. AR-2180 tie rod has an extra tapered hole on the right to accept a drag link. Measure between the tapered holes and specify the length. Tie rod ends included. Stainless Steel is available

- AR-2180 Drag link, 36" or less \$100.00
- AR-2183 Tie rod, more than 36" long \$110.00
- AU-2190 Replacement Ford tie rod end (R) \$30.00
- AU-2191 Replacement Ford tie rod end (L)..... \$30.00



PERCH BOLTS

New plain style fits 1935-1948 Ford. Extra long for bolt on lower sway bar mount.

- AR-2210 Perch bolts..... pair \$43.50
- Ar-2212 Perch Nut pair \$7.00



SHACKLES

- 3321F Standard, front, 2"..... pair \$60.00
- AU2214 1935-48 rear end kit..... pair \$60.00



FRONT U-BOLTS SET

Fits 1935-48 front crossmember, stock or reproduction. u-bolts, nuts and bottom plate

- 1001set \$47.95
- 1001C Chrome.....set \$89.00



FORGED STEERING ARMS

Fits 1935-1948 Ford spindle, original or new. C.E. forged arms are pre-bent to fit dropped axles. Choice of standard or milled leg for disc brake adapter clearance. If your caliper adapter mounts on the inside of the spindle flange, then you need the milled leg option for clearance. Thru bolt design insures safety, eliminating the possibility of blind threads stripping or pulling loose. These are deep drop design to clear 1935-1948 Ford and Mercury wishbones.

- 1108D Standard..... \$130.00
- AR-2121M Milled leg \$140.00



HEIDTS SUPER RIDE II

Give your Fat Fendered Ford a smooth ride, good handling, and the ultimate look with Heidt's Superide II - A complete front suspension kit which includes: main crossmember, dropped spindles, adjustable tubular A-arms, adjustable coil over shocks with chrome springs, 11" disc brake vented rotors, billet calipers or GM calipers, front mounted rack and pinion steering, and factory ball joints & tie rod ends.

OPTIONS AVAILABLE: stainless steel, control arms, power rack and pinion, sway bar, polished shocks and polished calipers.

- 1941-48 Ford Car/Pick-up..... \$4,495.00
- Polished stainless steel package \$1,650.00

1941-1948 Ford Front Suspension



CHASSIS ENGINEERING BOLT-ON PINTO I.F.S. FEATURES ADJUSTABLE RIDE HEIGHT

Bolt-on crossmember uses Pinto/Mustang II suspension components. Because the stock Pinto/Mustang II is too narrow to fit the 1942-1948 Ford correctly, Chassis Engineering has widened the crossmember and rack 2" and adjusted some pivot points. The result is a suspension that is actually superior to the original with no bump steer or other unpleasant surprises. Upper coil spring pods are adjustable for ride height, giving a 2 1/2" adjustment at the wheel, an excellent method of fine tuning final ride height to your taste. The car will sit low normally. Support rods are included to strengthen the lower strut rod mount. Interlocking tabs between upper pods and crossmember prevent movement. This kit is 3" narrower than stock 1942-1948 Ford and will also fit the narrower 1941 cars if you are careful with wheel size. Note: requires engine mount CP-2102P for Chevy engine.

- IF-4248FP 1941-48 Cars \$1012.00
- Installed weld-on option Add \$90.00
- Complete suspension component package \$2,200.00

HEIDT'S WELD-ON PINTO/MUSTANG II IFS KIT

Uses 1974-1980 Pinto or 1974-1978 Mustang II suspension components. Same geometry as original Mustang. Includes all pieces needed for installation. Ready to weld-on and bolt up Pinto/Mustang suspension parts. Because this kit is the stock Pinto width, it fits the narrower 1941 better.

- PX-103 1941-48 Cars \$425.00
- Crossmember complete kit with all parts \$1,799.00



MUSTANG II REPLACEMENT COIL SPRINGS

New coil springs are available in rates of 250-300-325-350 ft/lb. and the right length for street rod usage. Shortening is not necessary. Works with the above kit or other brands also. Non returnable item. Sold in pairs

- FS-8250 250 pound \$129.00
- FS-8275 275 pound \$129.00
- FS-8300 300 pound \$129.00
- FS-8325 325 pound \$129.00
- FS-8350 350 pound \$129.00

BOLT ON STEERING BOX ADAPTER

This is an excellent change. Mounts manual or power GM steering gear, to 1941-48 Fords. Late column or original may be fitted. Bolts and instructions included.

- AS-2094 1941-48 \$81.00



MASTER CYLINDER ADAPTER

Bolts Pinto-Mustang master cylinder to 1941-1948 Ford Pedal. Includes adapter, new shaft, spacers, bolts and instructions. Kit spaces pedal assembly over to clear turbo 350. Fitting is required.

- AS-2022 Adapter kit \$80.00
- AU2036 Mustang 15/16" bore, standard \$85.00
- AU-2037 Mustang 1" bore, standard \$85.00



POWER BRAKE BOOSTER- DUAL DIAPHRAGM

This 7 inch dual booster is an ideal size for most street rods

- AS-2075 7 inch dual booster \$145.00
- 8531 8 inch dual booster \$145.00



POWER BRAKE ADAPTER

Adapts Chassis Engineering power booster or stock Pinto booster assembly to the 1941-1948 Ford pedal. This is a good fit and well worth doing.

- AS-2058 \$90.00



1937-48 SPINDLE ECI BIG DISC BRAKE KIT

ECI's Disc Brake kits bolt-on to stock or reproduction 37-48 spindles. Kits include: GM full size car calipers/pads, 11 inch rotors with Ford or GM bolt pattern, bearings/adapters, seals, hardware, brackets and instructions

- EC-701CK GM 4-3/4" bolt circle \$425.00
- EC-709CK Ford 4-1/2" bolt circle \$425.00
- EC-730CK Ford 5-1/2" bolt circle, uses F150 rotors .. \$425.00 (see page 00 for complete listing)



DISK BRAKE KIT

A bolt on forged steel bracket for Pinto/Mustang spindles. Uses 11" Granada (1975-80) rotors which bolt to the Pinto/Mustang spindles, as is. Calipers are 1980-1983 Mustang (and several others) that are readily available. The original Pinto/Mustang discs are an undersized 9" and are often not adequate for street rod usage. Steel adapters are included to allow the use of braided lines. Adapters will also allow use of many different brake hoses.

AU-2045 \$145.00

CALIPERS AND ROTORS

11" rotors for the above kit.

AU-0126 Granada rotor (new) each \$65.00

AU-0114 Mustang caliper (rebuilt) each \$42.00



FRONT AND REAR SWAY BARS

This is an excellent way to improve the handling and overall driveability of the top heavy Fords. Eliminates road sway. For best results use front and rear bars together. All linkage and mounting hardware furnished.

SB-4148PM Front - Mustang/Pinto IFS. \$204.00

SB-4148WP Front -Chassis Engineering wide IFS. \$204.00

SB-4148R Rear - Chassis Engineering kit. \$204.00

SB-4148RA Rear - CE kit axle mount. \$210.00



REAR U-BOLTS

AU-2025C Set of 4 with nuts \$41.00

SPRING PADS

AU-2229 Weld on spring pad \$30.00



REAR SHACKLES

AU-2214 For Chassis Engineering kits, pair \$71.00



REAR SPRINGS

For use with the Chassis Engineering rear end mounting kit.

RS-4148 Regular street rod heightpair \$550.00

RS-4148LR Low Riderpair \$550.00



REAR END MOUNTING KIT

Completely bolt on kit uses 1968-1976 Nova, 1967-1969 Camaro and Firebird (multi leaf rear end), and 1957-1959 Ford 9 inch. The Ford Monarch and Granada rear ends will fit, but are narrow. Others will fit by moving pads. Uses two Dodge springs or Chassis Engineering's new slider springs. Kit includes right and left front hanger brackets, right and left rear brackets, bolts and instructions.

AS-2017 1942-48 Ford Cars. \$205.00



COMPLETE REAR END MOUNTING KIT

Includes above mounting kit, (4) U-bolts and nuts, rear shock kit with spring retainers, shocks, shackles, slider springs, bolts and instructions. Specify options below.

AS-2017C 1942-48 Ford Cars with standard or lowrider springs \$1,370.00

1941-1948 Ford Rear Suspension



REAR SHOCK KIT

Includes two upper shock brackets, two lower shock mount-spring retainers, bolts and instructions.

- AR-2049 Use with Nova or Camaro rear \$220.50
- AR-2048 All other rear ends..... \$230.50

REAR SHOCK ABSORBERS FOR ABOVE KIT

- AU-2221 Regular with special valving \$81.50
- AU-2221G Gas Filled \$81.50



UNIVERSAL REAR SHOCK KIT

- Brackets have 4 vertical positions to dial-in shock travel
- Features Pete & Jakes Rod shocks
- Includes shock studs and upper brackets

- 1073 1941-48 Ford..... \$130.00

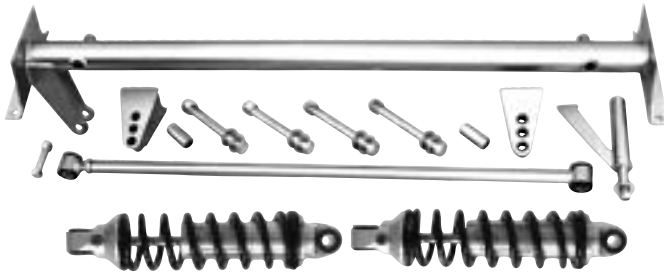

REAR COIL OVER SUSPENSION KIT

Tube crossmember replaces stock crossmember using stock rivet holes in frame for location and easy installation. Boxing plates, upper shock mounts, panhard bar brackets welded to crossmember. Lower shock mounts have 3 positions to adjust ride height. Panhard bar axle bracket welds to back side of rear end housing.

- 6013 1942-48 Ford \$425.00
- US502 QA-1 Coil Overs Altra-ride \$525.00

(spring rates: 130#, 170#, 200#, 220#, 250#, 300#, 350#)



TRIANGULATED LADDER BAR KIT

- Mounts rear end into 1942-48 Fords
- Pre-welded crossmember assembly welds into stock x-member
- Urethane bushings at front center pivot
- Adjustable clevis at rear
- Ultimate in strength and traction (specify housing diameter)

- 6011 1942-48 Ford \$475.00
- 6011DR Drag race version \$550.00



REAR PARALLEL 4-BAR KITS

The Parallel 4-Bar kit is very easy to install and is a good choice for many installations. It uses 1" x .156 tube bars with 3/4" stainless adjusters and urethane bushing, chassis mounting brackets, multi-position coil-over axle brackets and hardware. NOTE: These kits require the use of a Panhard Rod.

- 5017RP Universal - rear \$455.00
- Chrome add \$150.00



1941-1948 Ford Rear Suspension

We can build you a complete 1948-56 Ford Pickup frame using your existing frame or exchange it. Options are similar to our 1935-40 Ford car frame exchange program.



NEW!
48-64 Ford Truck X-Frame and 4-Bar kits, See page 125

1948-56 FORD TRUCK FRAME EXCHANGE PROGRAM

COMPLETE CHASSIS with IFS
Starting at **\$9,950.00** exchange

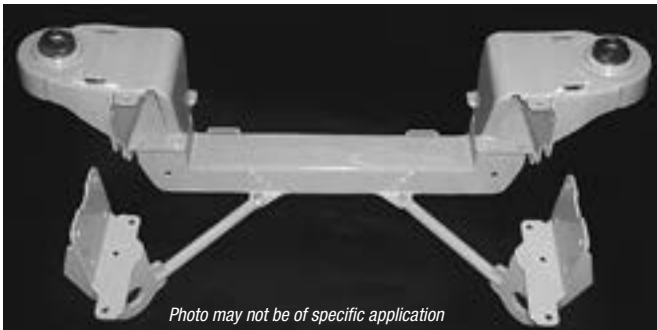

Photo may not be of specific application

1948-52 CHASSIS ENGINEERING BOLT-ON PINTO / MUSTANG II I.F.S. WITH ADJUSTABLE RIDE HEIGHT

This fully bolt-on crossmember uses Pinto or Mustang Suspension components. The stock Mustang/Pinto is too narrow to fit the 1948-52 Ford truck correctly, so Chassis Engineering has widened the crossmember and steering rack 2" and adjusted the pivot points. The result is suspension that is far superior to the original Mustang with no bump steer or other unpleasant surprises. The upper coil spring mounts are adjustable, giving 2-1/2" ride height adjustment at the wheel. This is the best method available to adjust ride height and maintain correct geometry. Center support rods add necessary strength to lower strut rod mounts and interlocking tabs between upper pods and crossmember prevent movement.

IF-4852FPT 1948-52 Ford pickup\$1,012.00
Complete suspension component package.....\$2,200.00



WELD-ON ENGINE MOUNTS INSTALLED OPTION

Engine mounts may be pre-welded to the above crossmember. Add \$80.00 to the kit price above.

CP-2151P Chevy small and big block V8 engine mounts \$125.00
CP-2251P Ford small block V8 engine mounts \$125.00

HANDY TOOL TO ADJUST RIDE HEIGHT ON THE C.E. I.F.S.

IF-0000W Adjustment wrench \$19.50

Trade in your original frame for a ready-to-roll street rod chassis!
The basic package includes:

- An original 1948-56 Ford truck frame sandblasted, repaired and primed
- Overdrive trans X-member modification
- Heidis Mustang crossmember kit and tubular A-arms
- Mustang II front suspension. Includes: new 5-bolt rotors, shocks, springs, spindles, and a manual rack & pinion steering gear
- Small block Chevy or small block Ford front & rear motor mounts
- 9" Ford rear end-used
- Chassis Engineering parallel leaf spring rear suspension
- Front and rear sway bars

.....\$9,950.00

Chassis are also available outright without a frame trade-in..... Core Charge \$500.00

Above chassis with NEW 9" Ford rear, drum brakes and choice of gear ratios \$ 9,950.00

Please see page 12 for options



Photo may not be of specific application

1948-56 WELD-ON MUSTANG/PINTO IFS KIT

Uses 1974-1980 Pinto or 1974-1978 Mustang II suspension components. Same geometry as original Mustang. Includes all pieces needed for installation. Ready to weld-on and bolt up Pinto/Mustang suspension parts. Because this kit is the stock Pinto width, it fits the narrower 1941 better. Economy kit's welds are not dressed

PX-104 1948-52 Ford F-1 crossmember kit \$575.00
PX-105 1953-56 Ford F-100 crossmember kit ... \$575.00

Call 402.886.2275 or click: www.heinzmanstreetrods.com

1948-1956 Ford Pickup Trucks

THE BEST RIDE IN TOWN FOR CLASSIC TRUCKS



HEIDTS SUPERIDE II FOR 1948-56 FORD TRUCKS

Give your Classic Ford truck a smooth ride, good handling, and the ultimate look with Heidts Superide II - *A complete front suspension kit which includes:* main crossmember, dropped spindles, adjustable tubular A-arms, adjustable coil over shocks with chrome springs, 11" disc brake vented rotors, billet calipers or GM calipers, front mounted rack and pinion steering, and factory ball joints & tie rod ends.

- BX-310** 1948-52 Ford pick-up\$4,775.00
- BX-316** 1953-56 Ford pick-up\$4,775.00

OPTIONS:

- Stainless steel control arms** add \$1500.00
- Power steering** add \$200.00
- Sway bar, plain** \$200.00
- Sway bar, chrome** \$415.00



1948-52 ENGINE MOUNTING KIT

Chassis Engineering kits include frame adapters, engine side mounts, thru bolt cushion set and instructions.

- CP-2150** Chevrolet small and big block V8 using original suspension. \$165.00
- CP-2250** Ford small block V8 using orig. susp. ... \$165.00



1948-52 TRANSMISSION CROSSMEMBERS

For trucks using a firewall swing type brake pedal assembly. Bolts to frame. Mounts most Ford and Chevrolet transmissions (Turbo 400 must use manual brakes with stock or C.E. pedal). Frame rails are straight in this area so transmission crossmember can be positioned as needed. Bolts and instructions included.

- ES-2150** 1948-52 Transmission crossmember. ... \$105.00

WITH MASTER CYLINDER MOUNT

For use with T-350, T-400, T-700, C4 Ford and Chevrolet transmissions. Includes a bracket to mount manual master cylinder under floor. Frame rails are straight in this area so transmission crossmember can be positioned as needed. Bolts to frame. Bolts and instructions included.

- ES-2051** above with M/C mount \$165.00



1948-52 FRONT AND REAR SWAY BARS

This is an excellent way to improve the handling and overall driveability of the Ford pickup. Eliminates road sway. For best results use front and rear bars together. Includes all linkage and mounting hardware.

- SB-0020PM** Front 1948-52 Fits C.E. IFS kit \$204.00
- SB-4852R** Rear 1948-52 Fits C.E. rear end kit. \$210.00



1948-52, 1953-56 FORD TRUCK 4-BAR KITS

Coil-over, 4-bar rear suspension provides the best ride for any classic truck. These kits attach directly to the stock frame rails. The adjustable axle brackets let you set ride height in one of three positions. A bolt-in upper crossmember for coil-overs is included. Kits available in plain steel or with polished stainless steel. Note: These kits require the use of a Panhard Rod. *Coil covers and panhard rod are sold separately*

- RB-1** 1948-52 Ford 4-bar kit, plain \$750.00
- RB-1SS** 1948-52 Ford 4-bar kit, stainless steel ..\$1,595.00
- RB-120** 1953-54 Ford 4-bar kit, plain \$750.00
- RB-120SS** 1953-54 Ford 4-bar kit, stainless steel ..\$1,595.00
- RB-121** 1955-56 Ford 4-bar kit, plain \$750.00
- RB-121SS** 1955-56 Ford 4-bar kit, stainless steel ..\$1,595.00

COIL OVERS

Aldan rear coil-overs are 15" extended, 11-7/8" compressed with spring rates of 180#, 200#, 220# and 250#. Other coil-overs sizes and spring rates are available.

- QA-1 Ultra-Ride** \$525.00

PANHARD RODS

Must be used with rear 1953-56 4-bar kits above

- RP-103** Bolt-on panhard rod kit, plain. \$105.00
- RP-103-SS** Bolt-on panhard rod kit, stainless steel .. \$305.00
- RB-110** Weld-on panhard rod kit, plain \$105.00
- RP-104-SS** Weld-on panhard rod kit, stainless steel . \$295.00

1948-1956 Ford Pickup Trucks



1948-52 COMPLETE REAR END MOUNTING KIT

Complete bolt-on kit that uses a wide variety of rear end choices. Uses two C.E. slider springs. Kit includes front and rear hanger brackets, 4 U-bolts and nuts, spring pads, rear shock kit with spring retainers, shocks, shackles, hardware and instructions.

AS-2020C 1948-52 Rear end kit. \$1,375.00

1948-52 REAR SPRING MOUNTING BRACKETS

This kit contains front and rear hanger brackets only from the above kit Includes bolts and instructions.

AS-2020 1948-52 Rear spring brackets only \$205.00

1948-52 REAR SHOCK KIT

Kit includes upper shock crossmember, two shock absorbers, two lower shock mounts from above kit and all needed bolts and instructions. Parts shown in the above kit photo

AR-2050 1948-52 Rear shock crossmember kit. . . \$275.00



1948-52 REAR SUSPENSION PARTS

REAR SHACKLES

AU-2214 For C.E. kits pair \$71.00

REAR SPRINGS

5 leaf, 2-1/2" wide, 5" free arch for use with AS-2020 brackets above.

RS-4148 pair \$550.00

REAR AXLE U-BOLTS

AU-2025C Set of 4 with nuts \$41.00

REAR AXLE SPRING PADS

AU-2229 Weld-on \$35.00



1937-64 FORD TRUCK ECI BIG DISC BRAKE KIT

ECI's Disc Brake kits bolt-on to stock or reproduction 37-47, 48-56 and 57-64 1/2 ton pickup spindles. Kits include: GM full size car calipers/pads, 11 inch rotors with Ford or GM bolt pattern, bearings/adapters, seals, hardware, brackets and instructions

EC-701CK 1937-48 Ford P.U., GM 4-3/4" B.C. \$425.00

EC-705CK 1949-56 Ford P.U., GM 4-3/4" B.C. \$450.00

EC-709CK 1937-48 Ford P.U., Ford 4-1/2" B.C. \$450.00

EC-710CK 1949-56 Ford P.U., Ford 4-1/2" B.C. \$450.00

EC-730CK 1949-56 Ford P.U., Ford 5-1/2" B.C.* . . . \$450.00

EC-731CK 1957-64 Ford P.U., Ford 5-1/2" B.C.* . . . \$450.00

* uses Ford F150 rotors



Bracket shown may vary depending on applications

1948-56 POWER BRAKE UNITS

These assemblies include an ECI seven inch power brake booster and dual master cylinder. Bracket mounts unit to the frame and stock pedal assembly.

EC-524 1948-52 Ford 1/2 ton pickup \$425.00

EC-522 1953-56 Ford 1/2 ton pickup \$425.00

1953-56 Ford standard shift. add \$50.00



1948-52 BRAKE PEDAL AND PEDAL MOUNT KIT

Works with the under floor original brake pedal with slight pedal modification. Bolts and instructions included.

AS-2053 Pedal arm and mount assembly. \$202.00

AS-2054 Brake pedal mount only \$165.00

Call 402.886.2275 or click: www.heinzmanstreetrods.com

1948-1956 Ford Pickup Trucks

Call Heinzman Street Rod Shop for 1965-70 Mustang suspension parts and accessories or if you would like to update your 'stang with more modern suspension, brakes and steering. We do complete Mustang restorations and late model Cobra engine swaps.

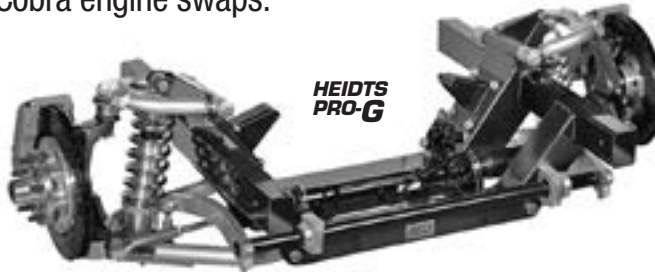

HEIDTS PRO-G

HEIDTS PRO-G FULL FRONT SUSPENSION KIT FOR 1964-1/2 TO 70 MUSTANGS

HEIDTS New Pro-G kits are designed from the ground up with race car designed geometry and a narrower track for wider tires. Base kit includes the crossmember, 2" dropped spindles, plain steel tubular upper & lower arms, power rack & pinion, 11" Wilwood disc brakes, billet coil-over shocks with chrome springs (choice of spring rates) and motor mounts for popular Ford engines, inner fender panels.

MTF-101 1964-1/2 -70 Mustang base kit \$6,500.00

A few of the many options include:

CF-103 Stainless steel control arms \$1,600.00

DF-222-D-B 12" Wilwood drilled rotors, 4 piston black calipers \$410.00

DF-223-D-B 13" Wilwood drilled rotors, 6 piston calipers, black or polished \$1,480.00

SB-403 Splined Sway Bar \$625.00



HEIDTS PRO-G

HEIDTS PRO-G INDEPENDENT REAR SUSPENSION KIT FOR 1964-1/2 TO 70 MUSTANGS

The Heidts PRO-G IRS system will totally transform your early Mustang. This is a bolt-in high-horsepower unit and includes sub-frame connectors that stiffen the body and locate the suspension. Included is a 9" Aluminum housing, posi-traction iron 3rd member, your choice of ratios, Wilwood 10.5" disc brakes, CV joint axles, billet adjustable coil-overs, crossmember and brackets, front pinion support and more. Track is 56.5".

IRM-101 1964-1/2 -70 Mustang- plain rotors . \$12,800.00

PX-330-E with drilled and slotted rotors \$13,200.00

Parking Brake kit available, please call.

Kits are not painted or assembled.



HEIDTS MUSTANG II IFS KIT FOR 1960-65 FALCON 1964-1/2 TO 70 MUSTANGS, 1967-70 COUGAR

HEIDTS suspension systems will give your Mustang, Cougar or Falcon the ride, handling and stopping power you are after. *Base kits include:* HEIDTS crossmember, 2" dropped spindles, tubular upper and lower arms, 11" rotors (Ford or Chevy bolt pattern), with single piston calipers, manual rack & pinion steering, stock shocks and springs

**Note: Rear sump style oil pan required. May not clear stock hood with some intakes. Ford 351 Cleavelands will not fit with these kits!*

PX-320-EK 1964-1/2 -70 Mustang base kit \$2,255.00

PX-330-EK 1964-65 Falcon base kit. \$2,255.00

A few of the many options include:

CA-112-SS Stainless steel control arms \$1050.00

DF-202-DBK 11" Wilwood drilled rotors, black 4 piston calipers (red and polished available) . . \$765.00

DF-206-DBK 13" Wilwood drilled rotors, black 6 piston calipers (red and polished available) . . \$1,585.00

MP-038-VCK Chrome power rack and pinion \$461.00

BS-002 Springs and coil-over shocks \$370.00

BS-061 Sway Bar, plain. \$200.00

HEIDTS SUPERIDE II IFS KIT FOR 1964-1/2 TO 70 MUSTANGS

HEIDTS kits include the crossmember and Boxing plates, 2" dropped spindles, plain steel tubular upper & lower arms or narrowed control arms, manual rack & pinion steering, 11" iron rotors with 4 piston Wilwood calipers (Ford or Chevy bolt pattern), billet single adjustable coil-over shocks with chrome springs (choice of spring rates).

**Note: Rear sump style oil pan required. May not clear stock hood with some intakes. Ford 351 Cleavelands will not fit with these kits!*

BX-320 1964-1/2 -70 Mustang base kit \$5,200.00

A few of the many options include:

BS-026 Stainless steel control arms \$1100.00

DF-202-DBK 11" Wilwood drilled rotors, black 4 piston calipers (red and polished available) . . \$431.00

DF-202-DBK 13" Wilwood drilled rotors, black 6 piston calipers (red and polished available) . . \$1,525.00

MP-038-VCK Chrome power rack and pinion \$461.00

BS-002 Polished billet coil-over shocks. \$75.00

BS-061 Sway Bar, plain. \$200.00

1965-1970 Ford Mustang Suspension



HEIDTS MUSTANG II CROSSMEMBER FOR 1960-65 FALCON, 1964-1/2 TO 70 MUSTANGS, 1967-70 COUGAR

Specially designed your Mustang, Cougar or Falcon with correct geometry built in. Includes weld in front boxing plates

- PX-320-E 1964-1/2 -70 Mustang base kit \$720.00
- PX-330-E 1964-65 Falcon base kit \$720.00



SWAY BAR FOR HEIDT'S FRONT ENDS

- SB-065 Sway bar \$389.00



INNER FENDER FILLER PANELS

Fills in the space where shock towers were.

- PX-325 1964-1/2 -66 \$99.00
- PX-326 1967-70 \$99.00



SUB FRAME CONNECTORS

For use with Heidts front and rear suspensions

- RM-102 Mustang Coupe or Fastback \$320.00
- RM-103 Mustang Convertible \$359.00
- RF-102 Falcon \$340.00



FORD MOTOR MOUNTS

For use with Heidt's front crossmembers

- MM-131 Motor Mount Stands for SB Fordpair \$79.00
- MM-135 Rubber Motor Mounts -SB Fordpair \$45.00



*Kits are not painted or assembled.
Housing not included*

HEIDTS REAR FOUR-LINK KIT FOR 1960-65 FALCON, 1964-1/2 TO 70 MUSTANG

Bolt on maximum performance for your Mustang or Falcon. *Kit includes* chassis and axle brackets, adjustable links, full upper coil-over crossmember, panhard bar, adjustable HEIDTS coil-overs and all hardware. Completely bolt-on, with no cutting or floor modifications. Adjustable 4-link mounts allow suspension tuning. Brackets must be welded to housing or housing with brackets installed is available. Will not fit Falcon Convertible, Ranchero or Cougar

- RM-101 1964 1/2 - 70 Mustang \$2,060.00
- RF-101 1960-65 Falcon \$2,060.00

Many brake, axle housing and spring options are available



Kits are not painted or assembled.

HEIDTS SUPERIDE II IFS KIT FOR 1966-67 FAIRLANES ,COMETS

HEIDTS crossmember and boxing plates, stock spindles (2" dropped spindles optional), plain steel tubular upper & lower arms or narrowed control arms, power rack & pinion steering, 11" iron rotors with 4 piston Wilwood calipers (Ford or Chevy bolt pattern), billet single adjustable coil-over shocks with chrome springs (choice of spring rates).

- BX-601 1966-67 Fairlane / 66-67 Comet \$4,960.00

Options are similar to other Superide II kits:



1965-1970 Ford Mustang Suspension

1964-1973 Ford Mustang Suspension

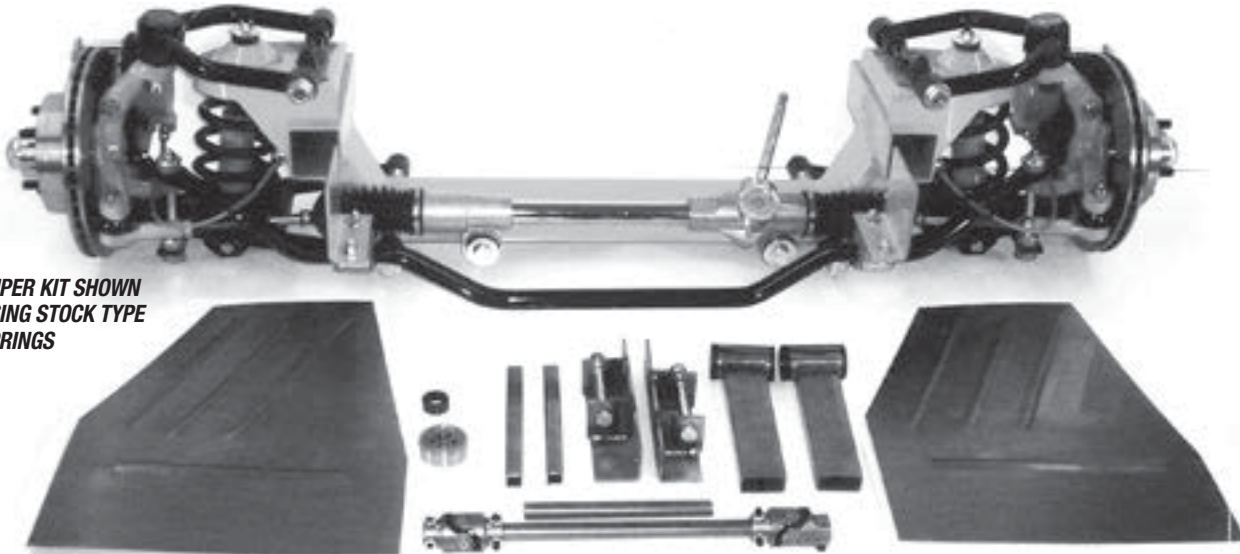

SUPER KIT SHOWN USING STOCK TYPE SPRINGS

Kits are not painted or assembled.

ROD & CUSTOM MOTORSPORTS MUSTANG II IFS KITS FOR 1964-73 MUSTANGS, 1960-70 FALCON/COMET, 1962-71 FAIRLANES, 1967-70 COUGARS

These Mustang II based kits use the stock springs and shocks and tubular control arms. By using this kit, you gain 7" of room on each side of the engine! *Base kits include:* crossmember, springs, shocks, upper and lower arms, manual rack with bushings and ends, spindles with nut kit, bearings and seals, 11" disc brake kit.

RC-103 Base kit.....\$2,995.00

SUPER KITS

These kits include everything in the base kit *plus:* motor mounts, 1" sway bar kit, tower replacement panels, stainless steel flex brake lines, steering shaft kit, column modification kit. *Options available:* larger brakes, powder coated arms, 2" dropped spindles, tilt column, and oil pans.

RC-106 Super kit (shown).....\$3,995.00



BASE KIT SHOWN USING COIL-OVER SHOCKS

ROD & CUSTOM MOTORSPORTS COIL-OVER KITS

These kits fit same applications as the stock coil spring kits. They also include adjustable coil-over upper mounts and coil-over shocks and springs.

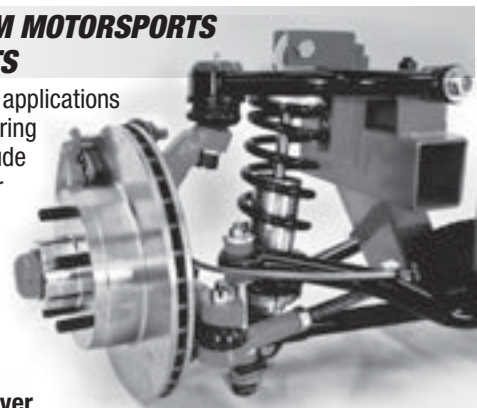

RC-104 Coil-over kit (Shown).....\$4,205.00
Power Rack (additional)..... \$150.00



ROD & CUSTOM MOTOR SPORTS MUSTANG II IFS CROSSMEMBER ONLY

Use this kit if you have your own components. Fits same applications as the complete kits. Available for stock coil springs or coil-overs.

- RC-101 Crossmember for stock style springs . . \$550.00
- RC-102 Crossmember for coil-over springs . . . \$550.00



ROD & CUSTOM MOTOR SPORTS REAR COIL-OVER KIT FOR 1960-65 FALCON & COMET, 1964-70 MUSTANG & COUGAR

This is a true bolt-in kit that uses the original rear end housing spring pads to mount the lower bars and coil over brackets. The upper bars mount to a bracket that bolts to the center section. Very easy to install. Includes sway bar.

- RC-114 Rear coil-over kit \$2,200.00

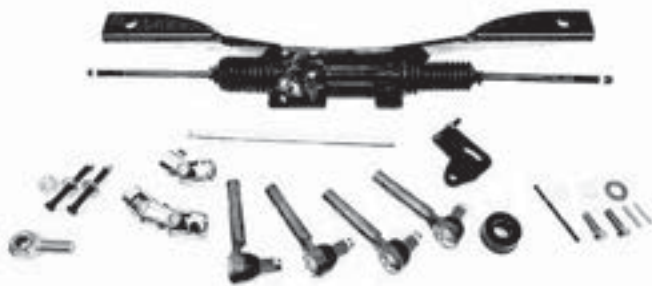

UNI-STEER RACK AND PINION KITS

These kits are for use with the stock front crossmember and suspension. Uni-Steer kits are true bolt-ons and easy to install. They will transform the handling and steering feel of your classic Ford.

1965-70 MUSTANG KITS

- 8001110-01 1965-66 Manual \$1,275.00
- 8001090-01 1967-70 Manual \$1,275.00
- 8010890-01 1965-66 Power, small block. \$1,850.00
- 8010830-01 1967-70 Power, small block. \$1,850.00
- 8010900-01 1965-66 Power, big block \$1,900.00
- 8010920-01 Late 1967-70 Power, big block \$1,900.00



BOOSTER/MASTER CYLINDER ASSEMBLIES

These new units include the mounting bracket and push rod. They are designed to use the original manual brake pedal and have the correct pedal ratio. Available with a drum or disc mater cylinder.

- DB107 1964-67 Mustang, 7", disc/drum \$259.00
- DB107-D 1964-67 Mustang, 7", disc/disc \$259.00
- DB108 1967-70 Mustang, 9", disc/drum \$259.00
- DB108-D 1967-70 Mustang, 9", disc/disc \$259.00



1965-70 MUSTANG TILT STEERING COLUMN

These new columns use all new parts and are available in paintable steel or polished stainless. Requires steering shaft and couplers/U-joints.

- FR20005 1965-66 \$489.00
- FR20004-69 1967-70 \$489.00



HIGH-POWER ELECTRIC BOOSTER AND MASTER CYLINDER ASSEMBLY

This high pressure system includes an electric remote booster that can be mounted anywhere in the car. This cleans up the firewall, frees up extra valve cover clearance and solves the low vacuum problem that many high performance engines have. Good looking, light weight and easy to install. Features a 1.125" bore, Dual circuits and built in metering/proportioning valve. Only 8" x 3.6" x 3.3".

- 10-56 Electric power brake booster/M.C. \$1,400.00

1964-1973 Ford Mustang Suspension

1934-36 Chevy Suspension



ENGINE MOUNTING KIT - SMALL BLOCK CHEVY V-8

Includes bolt on frame adapters (can be welded on) Chassis Engineering engine side mounts, thru bolt cushion set, bolts and instructions. Easy to install. For 1958 and up engines.

- CP-1105 1934-35 Chevy Standard \$201.00
- CP-1114 1936 with cross steering \$201.00
- CP-1115 1936 with stock steer & Pinto/Mustang. . . \$201.00

TRANSMISSION CROSSMEMBER KITS

Bolts in and is removable. Has separate clutch and brake pedal support. Use with Turbo 350, PG, standards or any transmission that measures 20-5/8" from bell housing to trans mounting bolts. Bolts and instructions are included

- ES1150 1934-35 Chevy Standard \$70.60
- CX1136 1934-36 Chevy Master \$560.00
- ES-1136 1936 Chevy Standard \$205.00



TRANSMISSION MOUNTING PLATE

Bolt-on plate fits original X-member. with minor modifications. Bolts and instructions included. For 350 Turbo, most powerglide and standards.

- ES-1150 Late 1934-35 Chevy Standard \$70.00



MUSTANG II FRONT CROSSMEMBER KIT

This Heidt's weld-on kit includes lower crossmember, upper spring mounts, boxing plates, rear strut mounts, gussets and instructions to mount 1974-78 Mustang II or 74-80 Pinto/Bobcat front suspension to your 1934-36 Chevy. Gives a low stance and nice ride. Note: requires extensive welding. *Crossmember only.*

- CX-101 1934-35 Standard \$590.00
- CX-111 1934-36 Master \$590.00



1934-35 CHEVY STANDARD REAR END MOUNTING KIT

Weld-on kits include right and left front and rear spring mounts, (4) U-bolts and nuts, rear shock kit with spring retainers, shocks, shackles, slider springs, bolts, and instructions. Requires trimming and welding

- AS0010C 1934-35 Standard (requires welding) . . \$1,370.00
- AS0010CG 1934-35 Standard with gas shocks . . \$1,370.00



1936 CHEVY STANDARD REAR END MOUNTING KIT

Bolt-on kit includes right and left front and rear spring mounts, (4) U-bolts and nuts, rear shock kit with spring retainers, shocks, shackles, slider springs, bolts, and instructions. Kits use 1968 -1976 Nova multi-leaf rear ends or 1967-69 Camaro or Firebird. Best choice is the Ford Granada and Monarch rear ends (8 inch). Rear ends require no modifications. To use other rears, spring pads must be welded on rear end. Easy bolt-in installation

- AS-1017CC 1936 Standard for Camaro-Nova rear . \$1,370.00
- AS-1017CF 1936 Standard for Ford and others . . \$1,370.00



1936 CHEVY MASTER REAR END MOUNTING KIT

Weld-on kit includes right and left front and rear spring mounts, 4 U-bolts and nuts, rear shock kit with spring retainers, shocks, shackles, slider springs, bolts, boxing plates and instructions. Kits use 1968 -1976 Nova multi-leaf rear ends or 1967-1969 Camaro or Firebird. Best choice is the Ford Granada and Monarch rear ends (8 inch). Rear ends require no modifications. To use other rears, spring pads must be welded on rear end. Easy bolt-in installation

AS-1016CC 1936 Master for Camaro-Nova rear . . . \$1,370.00

AS-1016CF 1936 Master for Ford and others \$1,370.00

REAR SPRING MOUNTS

Weld-on universal front and rear spring brackets for use with Chassis Engineering slider Springs.

AS-0010 Universal spring brackets \$100.00



FRONT & REAR SWAY BAR

These anti-sway bars work with Mustang II IFS and the Chassis Engineering rear leaf spring kit. Eliminates road sway and makes the top heavy Chevys into an excellent cornering and handling car. For best results use front and rear sway bars together. All linkage and mounting hardware furnished. State rear housing size. Rear must be used with CE rear shock kit.

SB-1041PM 1936 Front - Pinto/Mustang II IFS \$195.00

SB-1036R 1936 Rear - use with C.E. kit \$205.00



ECI DISC BRAKE CONVERSIONS FOR STOCK AXLE

ECI early Chevrolet disc brake kits are engineered and designed to bolt on stock Chevrolet spindles. Absolutely no machine work is required. Installs with simple hand tools and the components supplied in the kit. Complete instructions are provided.

Kits include caliper mounting brackets, attaching hardware, bearing adapters where required, new rotors, new calipers with semi-metallic pads and mounting bolts, new inner and outer bearing and seals.

EC-711SCK 1928-40 cars & pickups w/straight axle . . \$450.00



1934-36 Chevy Suspension

1937-39 CHEVY Hot Rod Suspension Parts

**WE HAVE A 1937-48 CHEVY FRAME EXCHANGE SIMILAR TO OUR FORD PROGRAM.
Please see page 12 or please give us a call for more information.**



CP-1101
Shown



CP-1103
Shown

ENGINE MOUNTING KIT - SMALL BLOCK CHEVY V-8

Chassis Engineering Engine mounts and crossmembers are especially engineered to work with Chevy's unusual "Top Hat" frame design. Kits include bolt on frame adapters (can be welded on) Chassis Engineering engine side mounts, thru bolt cushion set, bolts and instructions. Easy to install. For 1958 and up engines.

- CP-1100 1937-39 Small block kit\$180.00
- CP-1102 1939 Deluxe, small block kit Also fits 1937-39 with Chassis Engineering cross steering. Left mount offset for needed clearance.\$190.00



ES-1124-1125
Shown



ES-1126

TRANSMISSION CROSSMEMBER KITS

Bolts in and is removable. Has separate clutch and brake pedal support. Bolts and instruction are included. For use with.

- ES1124 1937-39 -Turbo 350, Powerglide, and standard or any trans. 20-5/8" from bell housing to trans mount.\$375.00
- ES-1126 1937-39 Turbo 400.\$375.00
- ES-1125 700R4 Overdrive Transmission\$375.00



BOLT-ON PINTO/MUSTANG II I.F.S. WITH ADJUSTABLE RIDE HEIGHT

Fully bolt-on crossmember uses Pinto/Mustang II suspension components. Stock Pinto-Mustang geometry is built in so there is no bump steer or other unpleasant surprises. Upper coil spring pads are adjustable, giving a 2 1/2" ride height adjustment at the wheels, an excellent method of fine tuning final ride height. Includes strut rod frame brackets with reinforcing rods built in for extra strength. Upper spring pads Interlock with crossmember for rigidity.

- IF-3739CP 1937-39 Chevy\$1,098.00
- Hub-to-hub kit\$2,200.00



Crossmember only

WELD-IN MUSTANG II FRONT CROSSMEMBER KIT

This Heidts kit includes lower crossmember, upper spring mounts, boxing plates, rear strut mounts, gussets and instructions to mount 1974-78 Mustang II or 74-80 Pinto/Bobcat front suspension to your 1934-39 Chevy. Gives a low stance and nice ride. Note: requires extensive welding. Economy kit does not have dressed welds

- CX-102 1937-39.....\$570.00
- 1937-39 sway bar kit\$195.00



FRONT & REAR SWAY BAR

An ideal combination with our dual leaf rear end kit. Eliminates road sway and makes the top heavy Chevs into an excellent cornering and handling car. For best results use front and rear sway bars together. All linkage and mounting hardware furnished. State rear housing size. Rear must be used with CE rear shock kit.

- SB-1037PM 1937-39 Front - Pinto/Mustang II IFS . . \$195.00
- SB-1037R 1937-39 Rear - use with C.E. kit\$205.00

1937-1939 Chevy Suspension



REAR END MOUNTING KIT

Bolt-on kit with no modifications of any kind to rear end. Easy installation, just remove old mounts and bolt these in their place. *Kits include* right and left front and rear spring mounts, (4) U-bolts and nuts, rear shock kit with spring retainers, shocks, shackles, slider springs, bolts, and instructions. Kits use 1968-1976 Nova multi-leaf rear ends or 1967-1969 Camaro or Firebird. Best choice is the Ford Granada and Monarch rear ends (8 inch). To use other rears, spring pads must be welded on rear end.

- AS-1018CC 1937-39 for Camaro-Nova rear \$1,370.00
- AS-1018CF 1937-39 for Ford rears and others. . . \$1,370.00



BASIC REAR END MOUNTING KIT

Bolt-on kit includes right and left front and rear spring mounts, hardware, and instructions. Kits use Dodge springs or Chassis Engineering slider springs. Note: 1941-48 require a wider rear end. Use a rear that measures at 60 inches wheel flange to wheel flange. 1968-1975 Nova is ideal.

- AS-1018 1937-39 \$145.00

BRAKE PEDAL & MASTER CYLINDER MOUNTING KIT

Bolt-in mounts adapt Ford Mustang (non-power) master cylinders to 1937-48 Chevy cars. 1941-48 mount uses original pedal arm. 1937-39 is a complete assembly with swing arm and mount. Both units are bolt in.

- AS-1026 1937-39. \$200.00
- AS-1041 1941-48. \$110.00



1940-48 Chevy Hot Rod Suspension Parts



ENGINE MOUNTING KIT - SMALL BLOCK CHEVY V-8

Chassis Engineering Engine mounts and crossmembers are especially engineered to work with Chevy's unusual "Top Hat" frame design. *Kits Includes* bolt on frame adapters (can be welded on) Chassis Engineering engine side mounts, thru bolt cushion set, bolts and instructions. Easy to install. For 1958 and up engines.

- CP-1106 1940 Solid Axle \$190.00
- CP-1106A 1940 Original Chevy IFS \$190.00
- CP-1106GB 1940 Use with Competition Engineering or other bolt-in Mustang II IFS kits \$193.00
- CP-1107 1941-48 Original Chevy IFS. \$165.00
- CP-1107G 1941-48 Use with Competition Engineering or other bolt-in Mustang II IFS kits \$193.00



TRANSMISSION MOUNTING PLATE

For use with only V-8 engines. Bolt-on plate fits original crossmember with minor modifications. Bolts and instructions included. For 350 Turbo, most powerglide and standard transmissions.

- ES-1170 1940-48. \$35.00

GENERAL SWAP INFORMATION

Chassis Engineering engine mount kits are bolt-in, easy to use and solve two major problems associated with this swap: the transmission crossmember is not cut and there is clearance around the steering box to use a stock exhaust manifold. NOTE: the 1940 frame is different. Most parts will interchange, but not all.



RADIATOR SUPPORT

For use with Mustang II crossmember or for anyone who needs a replacement.

- AU-2254 1937-39 \$117.00
- AU-2255 1940-48 \$117.00

1937-1939 Chevy Suspension

1940-1948 Chevy Suspension

1940-1948 Chevy Suspension



BOLT-ON PINTO/MUSTANG II I.F.S. WITH ADJUSTABLE RIDE HEIGHT

Fully bolt-on crossmember uses Pinto/Mustang II suspension components. Stock Pinto-Mustang geometry is built in so there is no bump steer or other unpleasant surprises. Upper coil spring pads are adjustable, giving a 2-1/2" ride height adjustment at the wheels, an excellent method of fine tuning final ride height. Includes strut rod frame brackets with reinforcing rods built in for extra strength. Upper spring pads Interlock with crossmember for rigidity. An easy way to get late model suspension, steering and brakes on a classic Chevy

- IF-4040CP** 1940 Chevy \$1,098.00
- IF-4148CP** 1941-48 Chevy \$1,098.00
- AU-2255** 1940-48 Radiator Support \$123.00
- Hub-to-hub kit** \$2,200.00



MUSTANG II FRONT CROSSMEMBER KIT

This kit includes lower crossmember, upper spring mounts, boxing plates, rear strut mounts, gussets and instructions to mount 1974-78 Mustang II or 74-80 Pinto/Bobcat front suspension to your 1940-48 Chevy. Gives a low stance and nice ride. Note: requires extensive welding. Economy kit does not have dressed welds

- CX-103** 1940-48 Heidt's Weld-in crossmember . \$570.00
- 1940-48 sway bar kit \$195.00



FRONT & REAR SWAY BAR

An ideal combination with our dual leaf rear end kit. Eliminates road sway and makes the top heavy Chevys into an excellent cornering and handling car. For best results use front and rear sway bars together. All linkage and mounting hardware furnished. State rear housing size. Rear must be used with CE rear shock kit.

- SB-1041PM** 1940-48 Front - Pinto/Mustang II IFS . . \$195.00
- SB-1041R** 1940-48 Rear - use with C.E. kit \$205.00



REAR END MOUNTING KIT

Bolt-on kit with no modifications of any kind to rear end. Easy installation, just remove old mounts and bolt these in their place. Kits include right and left front and rear spring mounts, (4) U-bolts and nuts, rear shock kit with spring retainers, shocks, shackles, slider springs, bolts, and instructions. Kits use 1968-1976 Nova multi-leaf rear ends or 1967-1969 Camaro or Firebird. Best choice is the Ford Granada and Monarch rear ends (8 inch). To use other rears, spring pads must be welded on rear end. Note: 1941-48 require a wider rear end. Use a rear that measures at 60 inches wheel flange to wheel flange. 1968-1975 Nova is ideal.

- AS-1020CC** 1940 only for Camaro-Nova rear \$1,370.00
- AS-1016CF** 1940 only for Ford and others \$1,370.00
- AS-1019C** 1941-48 includes weld on spring pads. \$1,370.50



BASIC REAR END MOUNTING KIT

Bolt-on kit includes right and left front and rear spring mounts, hardware, and instructions. Kits use Dodge springs or Chassis Engineering slider springs. Use a rear that measures at 60 inches wheel flange to wheel flange. 1968-1975 Nova is ideal.

- AS-1019** 1941-48 Basic bracket kit \$145.00



MASTER CYLINDER MOUNTING KIT

Bolt-in mounts adapt Ford Mustang (non-power) master cylinders to 1941-48 cars. Mount uses original pedal arm.

- AS-1041** 1941-48 Bolt-in master cylinder mount. . . \$110.00



ENGINE MOUNTING KIT

Includes bolt on frame adapters (can be welded on), C.E. engine mounts, thru bolt cushion sets, bolts and instruction. Easy to install. Use this kit with original front suspension.

CP-1109 1949-54 Chevy passenger car..... \$195.00

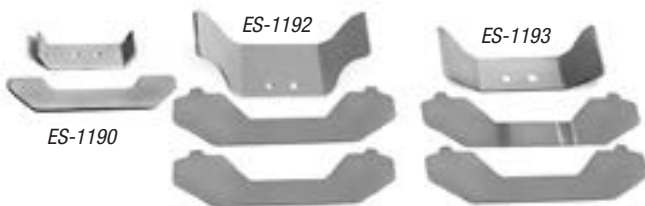

TRANSMISSION MOUNTING KITS

There are different transmission crossmembers used from 1949-1954. Select the kit that matches the year of car and the transmission that originally came with the car. All kits will adapt the Turbo 350, Powerglide or standard transmissions to 1949-1954 Chevy crossmember. The original crossmember must be modified using this kit and the enclosed directions. All require some cutting and welding. Does not fit Turbo 400. Does not fit if car was originally an automatic or a convertible.

ES-1190 1949-51 original 3 speed..... \$70.00
ES-1192 1952-54 original 3 speed & powerglide.... \$70.00
ES-1193 1952-54 original 3 speed & powerglide use with 700R4..... \$75.00



BOLT-ON PINTO/MUSTANG I.F.S. CROSSMEMBER

Fully bolt on Chassis Engineering crossmember uses factory Pinto/Mustang geometry so there is no bump steer or other unpleasant surprises. Pinto/Mustang parts are used except for the lower control arm. Because of clearance issues, this kit uses a one piece lower control arm instead of the original strut rod (available on page 59, # CA103). Upper coil spring pods are adjustable giving 2-1/2" ride height adjustment at the wheel. An excellent method of fine tuning the ride height to your taste. The car will sit low normally, so unless you're a fanatic, no further lowering is needed. Interlocking tabs between upper pods and lower cross member prevent movement.

IF4954CP 1949-54 Chevy IFS crossmember.....\$1,098.00
Weld-on installation option..... add \$120.00
Hub-to-hub kit.....\$2,200.00

Note: Requires engine mount Part number CP1109G



WELD-ON PINTO/MUSTANG II I.F.S. CROSSMEMBER

Heidt's weld-on kit retains the original Mustang geometry and uses 1974-1980 Pinto or 1974-1978 Mustang II suspension components. Includes all pieces needed for installation. Just weld kit on and bolt on Pinto/Mustang II suspension parts. Requires extensive welding. The economy kit does not have dressed welds.

CX104 1949-54 Chevy IFS crossmember..... \$570.00



COMPLETE REAR END MOUNTING KIT

Bolt-on kit for the 1949-1954 Chevrolet car. Uses Chassis Engineering Slider Springs. Kit includes right and left front and rear spring mounts, (4) U-bolts and nuts, rear shock mounts with spring retainers, shocks, shackles, slider springs, bolts and complete instructions.

AS-1021C 1949-54 Chevy passenger car..... \$1,370.00

1949-1954 Chevy Suspension

1937-1959 Chevy Pickup Suspension

COMPLETE CHASSIS with IFS

Starting at **\$8,995** exchange

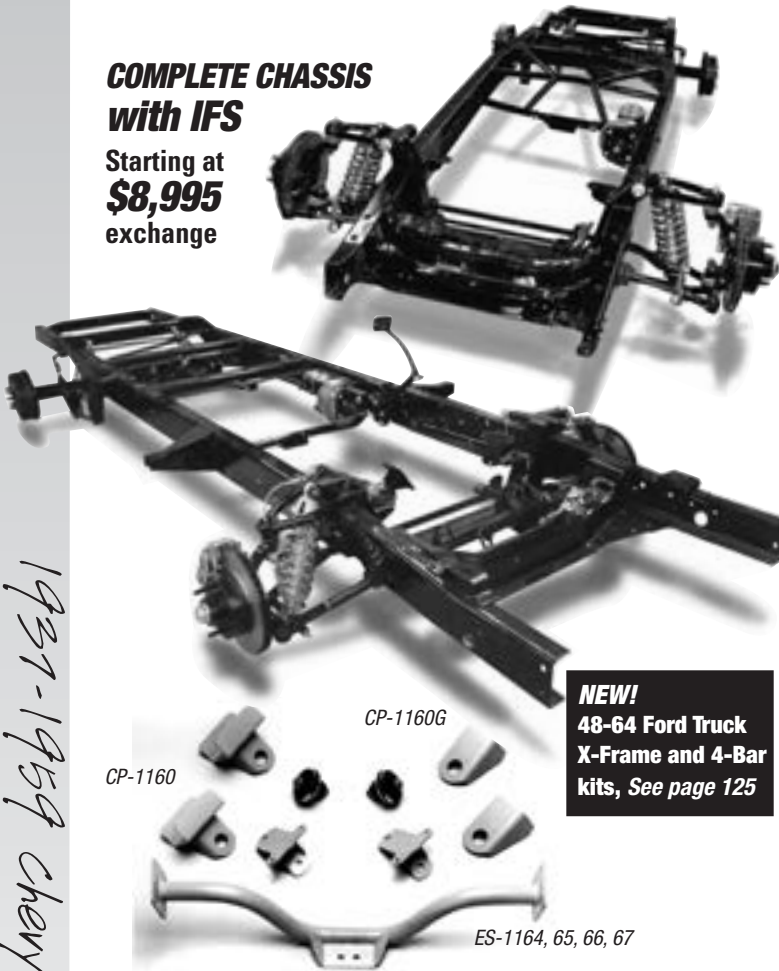

NEW!
48-64 Ford Truck X-Frame and 4-Bar kits, See page 125

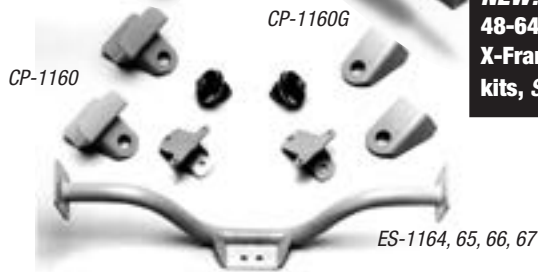

ENGINE MOUNTING KIT

Includes bolt-on frame adapters (can also be welded on), Chassis Engineering engine side mounts, thru bolt cushion set, hardware and instructions. Easy to install.

- CP-1160 Engine Mounting Kit \$145.00**
- CP-1160G Engine Mounting Kit- weld-on for non-CE Pinto/Mustang IFS crossmembers. \$145.00**



BOLT-ON PINTO/MUSTANG II I.F.S. WITH ADJUSTABLE RIDE HEIGHT

Fully bolt-on Chassis Engineering crossmember uses Pinto/Mustang II factory geometry and suspension components. The standard Mustang track is increased 2" to fit the wider Chevy trucks correctly. The upper coil spring pads are adjustable, giving 2-1/2" of ride height adjustment at the wheels. Includes strut rod frame brackets with reinforcing rods that tie into the crossmember in for extra strength. Upper spring pads interlock with crossmember for rigidity.

- IF-4854CPT 1948-54 Chevy Truck- 1/2 ton only . . . \$1,012.00**
- IF-5559CPT 1955-59 Chevy Truck- 1/2 ton only . . . \$1,012.00**
- CP-1160P with engine mounts installed \$120.00**
- Complete suspension component package \$2,200.00**

1937-59 CHEVY TRUCK FRAME EXCHANGE PROGRAM

Trade in your original frame for a ready-to-roll street rod chassis!

The basic package includes:

- An original 1947-54, 1955-59 Chevy truck frame sandblasted, repaired and primed
- Overdrive trans X-member modification
- Heidis Mustang crossmember kit and tubular A-arms
- Mustang II front suspension. Includes: new 5-bolt rotors, shocks, springs, spindles, and a manual rack & pinion steering gear
- Small block Chevy or small block Ford front & rear motor mounts
- 8" Ford rear end-used (9" rear available)
- Chassis Engineering parallel leaf spring rear suspension
- Front and rear sway bars

1935-40/1941-48 exchange \$8,995.00

Chassis are also available outright without a frame trade-in. Core Charge \$500.00

Above chassis with NEW 9" Ford rear, drum brakes and choice of gear ratios **\$ 9,975.00**

Please see page 12 for options



WELD ON PINTO/MUSTANG II IFS KIT

This Heidis weld-on kit includes lower crossmember, upper spring mounts, boxing plates, rear strut mounts, gussets and instructions to mount 1974-78 Mustang II or 74-80 Pinto/Bobcat front suspension to your 1937-54 Chevy truck. Gives a low stance and nice ride. Economy kit does not have dressed welds. Note: requires extensive welding.

- CX305 1937-1939 Pickup. \$570.00**
- CX306 1940-1946 Pickup, standard \$570.00**
- CX307 1947-1954 Pickup. \$570.00**
- CX308 1955-59 Pickup. \$570.00**



FRONT AND REAR SWAY BARS

Improves the handling of top-heavy classic trucks. For best results use front and rear bars together. Linkage and mounting hardware furnished. Upper linkage mount must be fabricated for rear bar.

- SB-0037R Rear- for Chassis Engineering rear end kit (specify axle housing diameter). \$205.00**
- SB-0010PM Front- most stock width Mustang IFS kits \$195.00**



HEIDTS SUPER RIDE II FOR 1947-54 CHEVY TRUCKS

Give your Classic Chevy truck a smooth ride, good handling, and the ultimate look with Heidt's Superide II - A complete front suspension kit which includes: main crossmember, dropped spindles, adjustable tubular A-arms, adjustable coil over shocks with chrome springs, 11" disc brake vented rotors, billet calipers or GM calipers, front mounted rack and pinion steering, and factory ball joints & tie rod ends.

- BX-306** 1947-54 Chevy pick-up. \$4,775.00
- BX-307** 1955-59 Chevy pick-up. \$4,775.00
- Options:**
 - Stainless steel control arms** add \$1,500.00
 - Power steering** add \$200.00
 - Sway bar, plain** \$225.00
 - Sway bar, Chrome** \$525.00

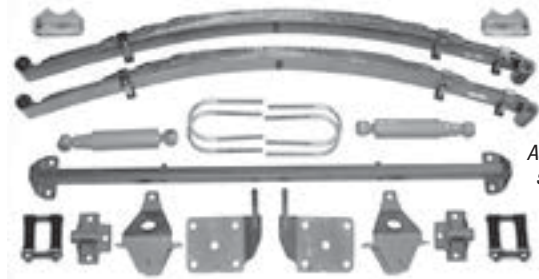

AS-1015 shown

REAR END MOUNTING KITS

- 1948-54 Bolt-On Kit** includes bolt-on spring mounts, (4) U-bolts with nuts, specially valved shocks, shackles, rear shock kit and Chassis Engineering Slider Springs. Spring pads must be welded to rear axle. This is an easy installation on original frames
- AS-1015C** 1948-54 Bolt On Rear End Kit. \$1,370.00
- 1937-47 Weld-On Kit** includes weld-on spring mounts, (4) U-bolts with nuts, specially valved shocks, shackles, rear shock kit and Chassis Engineering Slider Springs. Spring pads must be welded to rear axle. Fitting and welding required. Specify rear end used.
- AS-0010CY** 1937-47 Weld-on rear end kit \$1,370.00
- AS-0010CY** 1955-59 Weld-on rear end kit \$1,370.00

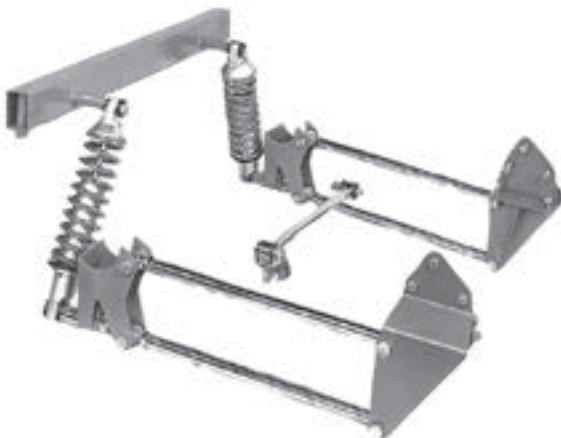

HEIDTS 1947-59 CHEVY TRUCK 4-BAR KITS

Coil-over, 4-bar rear suspension provides the best ride for any classic truck. These kits attach directly to the stock frame rails. The adjustable axle brackets let you set ride height in one of three positions. A bolt-in upper crossmember for coil-overs is included. Kits available in plain steel or with polished stainless steel. Note: These kits require the use of a panhard rod. Coil covers and panhard rod are sold separately

- RB-108** 1947-54 Chevy 4-Bar Kit, Plain \$850.00
- RB-108SS** 1947-54 Chevy 4-Bar Kit, Stainless Steel \$1,550.00
- RB-110** 1955-59 Chevy 4-Bar Kit, Plain \$850.00
- RB-110SS** 1955-59 Chevy 4-Bar Kit, Stainless Steel . \$1,550.00

HEIDTS COIL OVERS

Rear coil overs are 15" extended, 11-7/8" compressed with spring rates of 180#, 200#, 220#, 250#, 300#, 350#, 400# and 500#. Shocks are available plain or polished and springs are chrome.

- CD-109** Coil Overs, plain. \$525.00
- CD-105P** Coil Overs, polished. \$600.00

PANHARD RODS

Must be used with rear 1947-54 4-bar kits above

- RP-106** Bolt-on panhard rod kit, plain \$95.00
- RP-106-SS** Bolt-on panhard rod kit, stainless \$195.00

BRAKE PEDAL & MASTER CYLINDER MOUNTING KIT

- Bolt-in mounts adapt most master cylinders
- AS-1048PT** 1947-54 Chevy PU. . \$200.00



ECI MASTER CYLINDER ADAPTER

Adapts either Mustang or Corvette master cylinder to the stock brake pedal in the stock master cylinder location. Supplied with push rod, rod end, hardware and new boot.

- EC-420** 1947-54 Chevy P/U \$110.00
- EC-425** 1955-59 Chevy P/U \$200.00



EC-515 shown



EC-420 shown

ECI BOOSTER & MASTER CYLINDER ASSEMBLY

New master cylinder with 7" booster and bracket. Mounts to the stock brake pedal. Hardware included.

- EC-505** 1947-54 Chevy pick-up \$395.00
- EC-515** 1955-59 Chevy pick-up. \$395.00

ECI DISC BRAKE KITS

Uses GM rotors and calipers (large passenger car) and replaces the Chevy ball bearings with late GM/ tapered roller bearings and grease seals. Caliper brackets bolt to the stock spindles and stock GM steering arms are used.



- EC-711** 47-54 Chevy, basic kit. \$180.00
- EC-711CK** 47-54 Chevy, complete kit \$515.00
- EC-711X** 47-54 Chevy, basic kit. \$190.00
- EC-711XCK** 47-54 Chevy, complete kit \$450.00

Call 402.886.2275 or click: www.heinzmanstreetrods.com

1937-1959 Chevy Pickup Suspension and Brakes

1955-1957 Chevy suspension



CHASSIS ENGINEERING ENGINE MOUNTING KIT

Includes bolt on frame adapters (or can be welded on), engine side mounts, thru bolt cushion set, bolts and instructions. Easy to install. Engine sits in same location as original. Kit also fits Big Blocks.

CP-1112 Engine mounting kit \$201.00



TRANSMISSION MOUNTING KIT

1955-57 Chevy transmission crossmembers for any transmission

91628910 Transmission mounting kit \$125.00



HEIDTS TUBULAR UPPER A-ARMS

These tubular upper A-Arms are the ultimate in looks and a direct replacement for the stock originals. They include new design cross shafts which have offset built in to increase the amount of camber adjustment. All welds are heli-arc welded for maximum strength. The stainless arms are fully polished (except cross shafts). Arms are ready to install, including new cross shafts, ball joints and bushings.

CA-201 Tubular upper A-arms: plain pair \$615.00
CA-201SS Tubular upper A-arms: stainless . . . pair \$1,184.00



HEIDTS TUBULAR LOWER A-ARMS

A perfect match to Heidt's upper A-Arms. For stock springs or coil-overs. The lower ball joint is the correct compression type, not a tension ball joint turned upside down. Lower arms include stabilizer tabs and steering stops welded in place and a stamped spring pocket. Also included are new cross shafts, ball joints and bushings and come fully assembled, ready to install. Stainless steel arms are fully polished.

CA-203 Tubular lower A-arms: plain . . . pair \$1,070.00
CA-203SS Tubular lower A-arms: stainless . . pair \$2,140.00
CA-203-M Plain for coil-over shocks pair \$1,070.00
CA-203-SS-M Stainless steel for coil-over shocks . . pr \$2,140.00



QA1 COIL OVERS

Billet coil-over shocks have fully adjustable dampening. Silver powder coated full length progressive springs assure full travel and smooth ride with spring rates for small block and big block. They also fit stock lower arms using adapter kit CS-020.

GS501 Coil-over shocks pr \$629.00
450# 11" Coil-over springs, small block included
550# 11" Coil-over springs, big block included

Springs are available in 300-700 lb increments

HEIDTS 2" DROPPED STEEL SPINDLES

2" Dropped Steel Spindles are full steel spindles, just like factory spindles. This is much stronger than cast iron. They use your stock steering arms, with no loss of turning radius. No realignment required. The caliper brackets bolt on like mid-70's Chevys, allowing many brake options. Also available as a kit with late model GM caliber brackets.

SP-102 Spindles \$535.00
SP-102B Spindle kit with early Chevelle brackets . . \$535.00



1" DROPPED COIL SPRINGS

To give your "Shoobox" an even lower look, add these Heidts 1" dropped coil springs. Combined with Heidts 2" dropped spindles, they will put your cruiser a full 3" in the weeds safely and easily. For use with either sock arms or our tubular A-Arms.



CS-060 Dropped stock style springs \$149.00



STABILIZER BAR KITS

Stabilizer bars, or sway bars, are used to help control body roll and sway. Heidts Stabilizer Bars for 1955-57 Chevys are made of heat treated steel and are gold zinc plated. They are available in either 7/8" or 1" bar, with either rubber or urethane bushings.

SB-050-U 7/8" bar, urethane bushings \$195.00
SB-051-U 1" bar, urethane bushings \$195.00
SB-052-U Rear stabilizer bar kit \$205.00

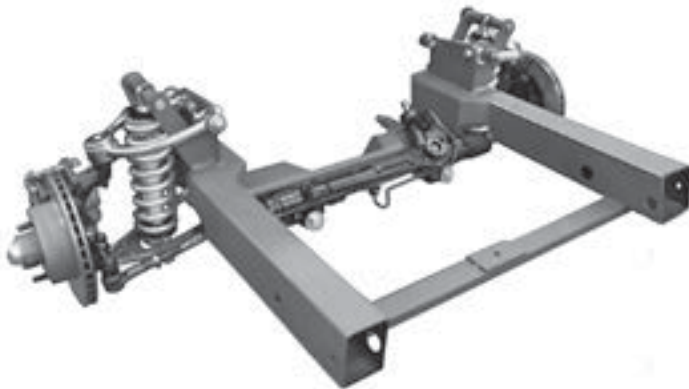

1955-56 CHEVY FATMAN MUSTANG II FRONT STUBS

Tri-Five Chevys have a frame design which doesn't allow for a simple Mustang II crossmember installation, yet are too narrow for a GM sub-frame. Fatman builds these weld-on clips which provide a 2-4" drop, and include pre-made mounts for bumpers, radiators and front sheet metal. Stock sheet metal remounts with very minor, or no trimming required. Please call for details.

Complete kit with stock springs \$3,450.00
Complete kit with coil overs \$3,995.00

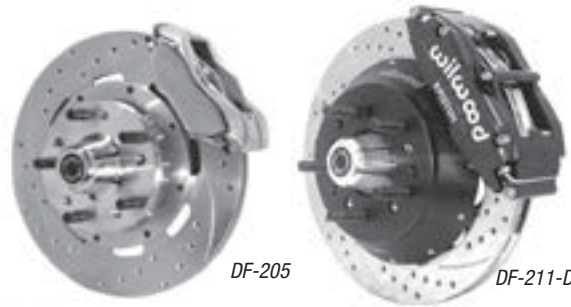

WILWOOD DISC BRAKE KITS

The ultimate upgrade for Heidts dropped spindles. Includes: Wilwood polished aluminum calipers with pads, polished aluminum hubs with 11" vented rotors, bearing and seals, caliper brackets and hardware. Braided stainless lines sold separately.

DF-205 11" Wilwood drilled rotors, 4 piston polished calipers & hardware \$1330.00
DF-205-D 11" Wilwood drilled rotors w/ polished hubs, 4 piston polished calipers & hardware . . \$1,570.00
DF-210-D 12" Wilwood drilled rotors w/ polished hubs, 4 piston polished calipers & hardware . . \$1,620.00
DF-211-D 13" Wilwood drilled rotors w/ black hubs, 4 piston black calipers & hardware . . . \$2,890.00



POWER BOOSTER & DUAL MASTER CYLINDER

Power Brakes for you 1955-57 Chevy. Kit includes: power booster, dual master cylinder and correct proportioning valve for disc-drum or disc-disc cars. Designed for use with our disc brake kits. Fully assembled and plumbed, ready for installation.

DB-116 Power booster, master cyl, disc/drum . . . \$329.00
DB-116D Power booster, master cyl, disc/disc . . . \$329.00
DB103 Manual master cylinder, disc/drum \$250.00
DB103D Manual master cylinder, disc/disc \$225.00



EC1 DISC BRAKE KITS FOR STOCK SPINDLES

Uses 1969-72 Chevelle/ Monte Carlo, 69-74 Nova rotor and caliper (or GM equivalents). Caliper brackets bolt to the stock spindles. No steering arm/tie rod relocating required. Replaces original ball bearings with late GM tapered roller bearings and grease seals.

EC-708 1955-58 Chevy, Bracket Kit \$195.00
EC-708CK Complete Kit \$525.00

1955-1957 Chevy Suspension

1955-1957 Chevy suspension



ECI POWER BOOSTER/MASTER CYLINDER

These systems come complete with new 7" booster and master cylinder assemblies and adapter brackets. They mount in the stock location and the original brake pedal is utilized. 9" booster is also available for 60% more assist (for small blocks only).

- EC-600** 1955-64 Chevy **\$295.00**
- EC-605** 1955-64 Chevy w/9" power booster **\$325.00**



UNI-STEER RACK & PINION CONVERSION KIT

Uni-steer's Tri-5 rack and pinion will greatly improve handling and steering effort, while maintaining road feel. This kit is specifically designed for the Tri-5's with the correct ball center dimension so there is no bump steer. Best of all, this is a BOLT-ON kit, no chassis modifications necessary. a manual rack is also available, recommended for racing.

- 8010600** Tri-5 Power rack & pinion kit **\$975.00**



GM 600 BOX POWER STEERING KIT

Bolt-in conversion kits use a remanufactured GM 600 power steering box modified to bolt to the 1955-57 Chevy frame. This is the newest technology from GM with a sporty 12.7:1 or 14:1 ratio for a modern steering feel. Cars with factory power steering require a drag link adaptor. Kit includes 600 power steering box, P/S pump with pulley and brackets, hoses and rag joint and column floor mount.

- 999009** 600 Power steering complete kit, 12.7:1 .. **\$991.00**
- CPP 600** Power steering gear only, 14:1 .. **\$449.00**



HEIDTS REAR TRIANGULATED 4-LINK KIT

HEIDTS 1955-57 chevy car triangulated 4-link kit is very popular because it does not require a panhard rod. Kit includes fully adjustable, 1-1/4" X .156 tube 4-bars with 3/4" stainless adjusters and urethane bushings, angled and straight chassis brackets, upper crossmember, standard black coil-overs and springs, tabs and hardware. These kits are available in plain steel or polished stainless steel tubes, plain or polished billet shocks and chrome springs. NOTE: Intended for stock or aftermarket frames. Also available with fully welded housing, 3rd member, axles and brakes. Please call.

- RC-151** 1955-57 Chevy starting at **\$2,060.00**



FLAMING RIVER TILT STEERING COLUMNS

Bolt-in column is Made-in-the USA from all new components. Includes the correct plug for your harness, turn, tilt levers, flasher button. Available, plain steel, chrome, black powder coated, brushed aluminum, polished aluminum.

- Column for floor shift** from **\$489.00**
- Column with column shift** from **\$829.00**



ALUMINUM RADIATORS AND ASSEMBLIES

Beautifully made high-performance aluminum radiators made by Performance Rod & Custom. These custom made radiators are designed to cool big motors in extreme conditions or just cruising around. Just the radiator is available or as a complete assembly with a replacement core support, splash apron and filler panels. Lots of extras are available such as electric fans, A/C condensers and trans coolers. Please call.

- 2110055** Radiator/core support assembly, basic. . . **\$795.00**



HEIDTS 1962-67 BOLT-ON SUB-FRAME/CROSS-MEMBER ASSEMBLY

Bolts-on, no welding required. Even the motor mounts are already welded in place. Simply unbolt your complete front clip and bolt-in the Heidt's Mustang II based suspension sub-frame. Install the firewall supports, bolt on the suspension parts and you are all set. The stock radiator mount even bolts right up. Heidt's full lower A-arms must be used because the factory strut rods don't work in this application. The *complete kit includes*: front sub-frame, tubular upper & lower arms, stock spindles, 11" Rotors with single piston calipers, manual rack & pinion steering, stock shocks and springs. *Options include* narrowed and polished stainless control arms.

CX-320S 1962-67 Sub-frame/crossmember kit. . . \$1,036.00
 Complete with suspension kit \$3,200.00



HEIDTS 1962-67 PRO-G BOLT-ON SUB-FRAME

This is a fully bolt-on suspension sub-frame package with true high performance purpose designed suspension with race car geometry. Make your early Nova handle like a 600 HP slot car! It just bolts to the firewall in place of the original sub-frame with no welding. This *complete kit includes*: billet coil-over shock assemblies with chrome springs, tubular control arms, dropped spindles, 11" Wilwood disc brakes, power rack and pinion, motor mount stands, firewall support tubes and inner fender panels. *Options include* stainless steel control arms, sway bar, 12 or 13" brakes with 4 or 6 pistons, power brake booster and steering hookup kit.

MVF-320 1962-67 Nova PRO-G sub frame \$7,140.00



HEIDTS 1962-67 NOVA REAR 4-LINK KIT

This Heidts suspension kit replaces the weak mono leaves with a complete coil-over 4-bar system with sub-frame connectors to stiffen the uni-body. Available as bolt or weld-in. *Kit includes*: 4-bars, panhard rod, axle and frame brackets, sub-frame connectors, upper coil-over bracket, transmission crossmember, standard black coil-over shocks and springs. Many brake and rear end options.

RN-101 1962-67 weld-in \$2,060.00
RN-101-B 1962-67 bolt-in \$2,060.00



HEIDTS 1962-67 SUPERIDE II BOLT-ON SUB-FRAME

This is a fully bolt-on suspension sub-frame package with all suspension components. It just bolts to the firewall in place of the original sub-frame with no welding. *This assembly includes*: fully adjustable billet coil-over shock assemblies (plain or polished), chrome springs, tubular control arms, 11" disc brakes with Wilwood 4 piston calipers, manual rack and pinion steering, motor mount stands and firewall support tubes. *Options include* narrowed control arms, adjustable firewall tubes, power rack, polished stainless control arms, polished billet hubs, dropped spindles, sway bar and inner fender panels. 12" or 13" brakes with 4 or 6 pistons are also available.

BX-320 1962-67 Superide sub frame \$5,260.00

INNER FENDER PANELS

Finishes up the installation of a Heidt's sub-frame kit. These inner panels bolt directly to the fenders, firewall and core support and include hood hinge mounting plates.

CX-325 1962-65 pair \$330.00
CX-326 1966-67 pair \$330.00



Call 402.886.2275 or click: www.heinzmanstreetrods.com

1962-1974 Chevy Nova Suspension

1962-1974 Chevy Nova Suspension



1962-67 CHEVY II FRONT FRAME

Detroit Speed's front frame is a bolt-in replacement for the original stock sub-frame. DSE's unique suspension geometry greatly improves handling and ride quality. Stamped crossmembers improve structural rigidity and the upper support bars feature rigid integral hood hinge mounting and are hidden when used with DSE's Chevy II inner fenders package. *Package includes:* tubular upper and lower control arms, coil-over shocks and springs, power rack and pinion steering, splined sway bar, C6 Corvette uprights and mounting for SBC and LS engines. Powder coating optional.

- 032031** 1962-1965, SBC or LS engine \$7,276.00
- 032033** 1966-1967, SBC or LS engine \$7,276.00



1968-74 NOVA HYDROFORMED SUB-FRAME

Detroit Speed's all new front sub-frame is a bolt-in replacement for the original stock sub-frame. It improves the handling and ride quality by utilizing DSE's unique suspension geometry. DSE features OEM style hydroformed frame rails and stamped crossmembers for strength and stiffness and precise quality. *The sub-frame comes complete with:* tubular upper and lower control arms, coil-over shocks and springs, power rack and pinion steering, splined sway bar, C6 Corvette uprights and mounting for SBC, BBC, LS1, LS2, and LS7 engines. Powder coating optional.

- 032001** 450 lb/in SBC, LS. \$7,276.00
- 032002** 525 lb/in BBC, Pontiac \$7,276.00



DSE QUADRA LINK™ REAR SUSPENSION

This is a great way to upgrade 1962-74 Nova original leaf spring suspension to an adjustable 4-link system. Detroit Speed's 4-link geometry is optimized to achieve the best possible ride, handling and improved anti-squat control. The long upper links provide great pinion and u-joint angle control and an adjustable panhard rod provides precise and effective rear axle lateral location during hard cornering. The new DSE "Swivel-Link™" allows the suspension to fully articulate without binding. Tuned high durometer rubber bushings are used in place of noisy heim- joints or urethane bushings. A rear upper shock crossmember strengthens the rear body and frame section. Use DSE Deep Tubs or stock tubs (please specify). *Kit includes:* Detroit Tuned' Coil-over shocks/springs and black powder coated 4-bars, brackets, panhard bar. Note: requires a 3" axle tube.

- 041707** 1962-1967 Chevy II \$3,698.00
- 041703** 1968-1974 Nova \$3,088.00

HEIDTS 1968-72 NOVA PRO-G SUB-FRAME

This new 68-74 bolt-on front sub-frame uses Heidts new Pro-G™ suspension package for unbelievable cornering and overall handling. Simply unbolt and remove your front sheet metal, engine/trans, old sub-frame, then slide in the new complete sub-frame. All the sheet metal bolts back in place *There are many control arm, sway bar, shock and brake upgrades. Please call.*

The base kit includes: Pro-G sub-frame, Pro-G 2" dropped spindles, transmission x-member, tubular upper and lower arms, power rack and pinion steering, 11" Wilwood brakes with black calipers, billet coil-overs, single adjustable shocks with chrome springs,

CF-101-WT 1968-72 Nova (includes trans crossmember) . . \$7,039.00



HEIDT'S 68-72 NOVA SUB-FRAME CONNECTORS

Completely bolt-on, with no cutting or floor modifications. Ties the front sub-frame into the rear spring mounts

- RN-056** 1968-72 Nova sub-frame connectors . . . \$330.00



**HEIDTS
PRO-G**

HEIDTS PRO-G INDEPENDENT REAR SUSPENSION KIT FOR 1962 TO 67 NOVAS

The Heidts PRO-G IRS system will totally transform your early Nova. This is a bolt-in high-horsepower unit and includes sub-frame connectors that stiffen the body and locate the suspension. Included is a 9" Aluminum housing, posi-traction iron 3rd member, your choice of ratios, Wilwood 10.5" disc brakes, CV joint axles, billet adjustable coil-overs, crossmember and brackets, front pinion support and more. Track is 56.5". A parking brake kit is available. Please call.

- NVR-101 1962-67 Nova- plain rotors \$12,800.00**
- NVR-101-S with drilled and slotted rotors \$13,700.00**



HEIDTS 1968-72 NOVA REAR 4-LINK

Bolt-on maximum performance for your Camaro/Firebird or Nova. *The base kit includes:* chassis and axle brackets, adjustable links, full upper coil-over crossmember, panhard bar, adjustable HEIDTS coil-overs and all hardware. Completely bolt-on, with no cutting or floor modifications. Adjustable 4-link mounts allow suspension tuning. There are many brake, stainless steel and rear end housing upgrades. Please call. The driveshaft loop is optional and connects to the sub-frame connectors.

- RC-101 1968-72 Nova \$2,065.00**



DSE REAR MINI-TUB KITS

Rear Mini-Tub kit moves the leaf springs in for more tire clearance. The kit includes: DSE deep tubs, rear upper shock crossmember, rear upper shock mounts, offset shackles, rear leaf springs, adjustable leaf spring pads, lower shock plates, U-bolts, mini-tub video including templates and detailed, installation instructions. You will need special DSE shocks and a narrowed fuel tank.

- 041207 1968-1974 Nova 2" Drop \$2,026.00**



UNI-STEER RACK & PINION CONVERSION KIT

Uni-steer's Chevy II/ Nova rack and pinion will greatly improve handling and steering effort, while providing modern road feel. This kit is specifically designed for the 1962-67 and 68-74 suspension, so there is no bump steer. Best of all, these are Bolt-on kits, no chassis modifications necessary. Manual and chrome racks are also available. The 1962-67 kit includes the power steering pump, brackets and hoses.

- 8010650-01 1962-67 power rack & pinion kit \$1350.00**
- 8000930-01 1962-67 Manual rack & pinion kit \$1024.92**
- 8010540-01 1968-74 Nova power rack & pinion kit . . . \$862.92**
- 8000770-01 1968-74 Nova manual rack & pinion kit . . \$646.92**



GM-DELPHI 600 POWER STEERING GEAR

This all new steering gear replaces the common GM 800 series power steering gear used from 1964 to 1992. It uses low friction gear design and precision rack and pinion valve technology for increased steering feel. Quick ratio 12.7:1 and 6 lbs lighter than stock. Original power pitman arm may be used. A 3/4 x 30 spline rag joint and new o-ring power steering hoses are needed

- 090204 1968-74 X-Body, ready to paint \$695.00**
- 090204C 1968-74 X-Body, ceramic coated. \$780.00**



DSE CHEVY II SUB-FRAME CONNECTORS

Detroit Speed weld in sub-frame connectors are fabricated from 2" x 3" x 0.095" wall rectangular steel tubing. Laser cut brackets attach to the rear of the sub-frame and rear frame rails. DSE connectors do not interfere with seat attachment hardware or the installation and removal of the rear leaf spring pocket. Can be installed on convertibles. Note: If not used with DSE Chevy II QUADRA Link™ you will need to purchase the DSE torque boxes.

- 010104 1962-67 Chevy II \$237.00**
- 9304115 1962-67 Chevy II torque boxes. \$199.00**

Call 402.886.2275 or click: www.heinzmanstreetrods.com

1962-1974 Chevy Nova Suspension

1962-1974 Chevy Nova Suspension



HEIDTS TUBULAR UPPER & LOWER CONTROL ARMS

Beef up your suspension and tighten your handling with Heidts tubular control arms. Both upper and lower arms are available in stock width or narrowed 1" per side. They come beautifully black powder coated, and are fitted with high performance urethane bushings and factory ball joints, ready to install in your chassis. The narrowed arms allow you to run wider tires, without rubbing the fenders. Lower arms are also available for coil-over shocks

- CA-301 68-72 Nova upper control arms \$450.00
- CA-301-N 68-72 Nova upper control arms-narrowed . . \$450.00
- CA-311 68-72 Nova lower control arms \$650.00
- CA-311-N 68-72 Nova lower control arms-narrowed \$650.00
- CA-311-M 68-72 Nova coil-over lower control arms . \$650.00
- CA-311-NM 68-72 Nova coil-over lower control arms . \$650.00
- 68-72 Nova coil-over lower control arms -narrowed \$650.00
- CC-064 Narrowed tie rod ends for narrowed control arms each \$22.00

HEIDTS TALL 2" DROPPED STEEL SPINDLE

The upper ball joint is raised 1-1/2" over the factory design to yield a better camber change during suspension movement. This corrects the excessive camber change of the original design. These spindles are STEEL, the strongest ones in the industry.



- SP-110 2" Dropped spindles Pair \$490.00

QA1 COIL OVERS

Billet coil-over shocks have fully adjustable dampening. Silver powder coated full length progressive springs assure full travel and smooth ride with spring rates for small block and big block. They also fit stock lower arms using adapter kit CS-020.



- GS401 Coil-over shocks pr 629.00
- 450# 10" Coil-over springs, smal block. . . included
- 550# 10" Coil-over springs, big block included

Springs are available in 300-700 lb increments



SWAY BAR FOR STOCK NOVA SUB-FRAME

- 1-1/8" diameter stiffer sway bar for the stock sub-frame. Bolts-on.
- SB-069 1968-72 Nova sway bar \$314.00

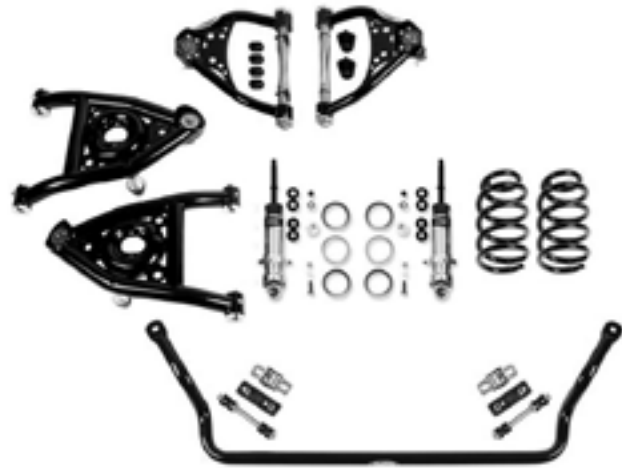

1968-74 NOVA DSE SPEED KITS

Detroit Speed's front suspension kits combine individual components into a system designed for your vehicle at three different levels. The DSE *Speed Kit 1* provides the ease of bolt-on components to improve your Nova's handling. The *Speed Kit 2* improves the handling performance to the next level and offers ride height adjustment.

Speed Kit 1: tubular upper control arms, tubular lower control arms, stock spring pocket, Koni classic front shocks, front 2" drop springs, front sway bar

Speed Kit 2: kit #1 with coil-over conversion kit, DSE tuned coil-over shocks, coil-over springs, and Torrington bearings

- 031301 1968-74 Speed kit 1 (specify SBC or LS). . . \$2,453.00
- 031350 1968-74 Speed kit 2 (specify SBC or LS). . . \$2,811.00



DSE REAR LEAF SPRING SUSPENSION KIT

This kit works great with any of the DSE front suspension systems. DSE leaf springs improve handling due to the increased spring rate and are available in either a 2" or 3" drop to lower ride height.

Kit includes: DSE rear leaf springs (2" or 3" drop), heavy duty shackle kit, Koni classic rear shocks

- 041633 Multi-Leaf spring- specify 2 or 3" drop. . \$1020.00

DSE DEEP WHEEL TUBS

These three inches wider wheel tubs will accept monster tires. They are stamped from 18 gauge steel in the USA, fit perfect, look stock and save a ton of work. The Deep Tub's can be purchased as a pair or as part of the complete mini-tub kit:



040402 Deep Tubs, 1968-1974 Nova pair \$485.00



HIGH-POWER ELECTRIC BOOSTER AND MASTER CYLINDER ASSEMBLY

This high pressure system includes an electric remote booster that can be mounted anywhere in the car. This cleans up the firewall, frees up extra valve cover clearance and solves the low vacuum problem that many high performance engines have. Good looking, light weight and easy to install. Features a 1.125" bore, Dual circuits and built in metering/proportioning valve. Only 8" x 3.6" x 3.3".

10-56 Electric power brake booster/M.C. \$1400.00

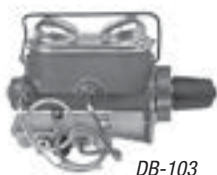

DB-103



DB-105

HEIDTS POWER BOOSTER & DUAL MASTER CYLINDER

Bolt-on kit for 1962-67. Kit includes: power booster, dual master cylinder and correct proportioning valve for disc-drum or disc-disc cars. Designed for use with our Disc Brake Kits. Fully assembled and plumbed, ready for installation.

DB-104 Power booster, master cyl, disc/drum. . . . \$330.00

DB-104-D Power booster, master cyl, disc/disc. . . . \$330.00

DB105 Manual master cylinder, disc/drum. \$175.00

DB105-D Manual master cylinder, disc/disc. \$175.00



62-74 NOVA DISC KITS FOR DRUM BRAKE SPINDLES

This ECI brake kit bolts to the stock drum brake spindle with no machine work or spindle modifications, and does not move the wheel out. The kit uses stock big piston GM calipers and 11-inch rotors on special billet hubs. Kit includes rotors, calipers with pads, bearings, seals, caliper mounting brackets, aluminum hubs and dust covers. Note: 62-63 Chevy II requires 64-67 spindles.

EC-723ACK 1968-74 Nova, \$575.00

Add \$100.00 for 13 in. rotors

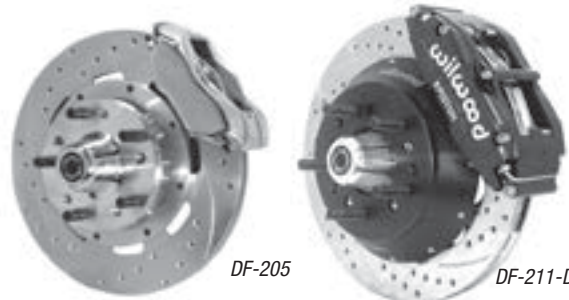

DF-205

DF-211-D

WILWOOD DISC BRAKE KITS

Four piston calipers, 11" rotors, 15" wheels, stock spindles

Wilwood's new limited offset FDL Pro-Series Front Hub Kits for 1964-1974 Chevy II/Novas offer a disc brake upgrade for the original Disc and Drum spindles. Wheels are only +.19" from original drum brake position, and -.31" from the original disc brake position. This kit provides plenty of clearance inside popular 15" wheels and can be used with either manual or power boost master cylinders. Kits come complete forged billet Dynalite calipers, rotors, hub assembly, brackets and hardware. Requires purchase of additional brake lines.

140-15272 Black anodize calipers, un-drilled rotors . . . \$795.00

140-1099L Black anodize, drilled & slotted \$1,042.97

There are many color and finish options available

Six piston calipers, 14" rotors, 18" wheels, stock spindles

The ultimate in big brakes for extreme performance and show with 6 piston calipers and stagger vaned rotors. Use with either manual or power boost master cylinders. Kits come complete with calipers, rotors, hub assembly, brackets and hardware. Requires purchase of additional brake lines.

140-10920 Black anodize calipers, slotted rotors . . \$2,603.00

140-1092D Black anodize, drilled & slotted rotors . \$2,738.00

Wilwood Discs Brakes For Heidt's Dropped Spindles

DF-205 11" drilled rotors, 4 piston polished calipers & hardware \$1,330.00

DF-205-D 11" drilled rotors w/ polished hubs, 4 piston polished calipers & hardware . . \$1,578.00

DF-210-D 12" drilled rotors w/ polished hubs, 4 piston polished calipers & hardware . . \$1,620.00

DF-211-D 13" drilled rotors w/ black hubs, 4 piston black calipers & hardware . . . \$2,896.00

1962-1974 Chevy Nova Suspension

1967-1981 Chevy Camaro Suspension



DSE HYDROFORMED SUB-FRAME

Detroit Speed's all new front sub-frame is a bolt-in replacement for the original 1967-69 and 1970-81 sub-frame. It improves the handling and ride quality by utilizing DSE's unique suspension geometry. DSE features OEM style hydroformed frame rails and stamped crossmembers for strength and stiffness and precise quality. *The sub-frame comes complete with:* tubular upper and lower control arms, coil-over shocks and springs, power rack and pinion steering, splined sway bar, C6 Corvette uprights and mounting for SBC, BBC, LS1, LS2, and LS7 engines. Powder coating optional.

032001	1967-69, 450 lb/in SBC, LS	\$7,900.00
032002	1967-69, 525 lb/in BBC, Pontiac.	\$7,900.00
032011	1970-81, 450 lb/in SBC, LS	\$9,000.00
032012	1970-81, 525 lb/in BBC, Pontiac.	\$9,000.00

DSE QUADRA-LINK™ REAR SUSPENSION

Detroit Speed's 4-link geometry is optimized to achieve the best possible ride, handling and improved anti-squat control. The long upper links provide great pinion and u-joint angle control and an adjustable panhard rod provides precise and effective rear axle lateral location during hard cornering. The new DSE "Swivel-Link™" allows the suspension to fully articulate without binding. Tuned high durometer rubber bushings are used in place of noisy heim- joints or urethane bushings. A rear upper shock crossmember strengthens the rear body and frame section. Use DSE Deep Tubs or stock tubs (please specify). *Kit includes:* Detroit Tuned' Coil-over shocks/springs and black powder coated 4-bars, brackets, panhard bar, shock mount/crossmember. Note: requires a 3" axle tube. Ford 9" housings and Chevy 12 bolt housings are available pre-welded.

041703	1967-1969 Camaro	\$3,038.00
041711	1970-81 Camaro	\$3,210.00
Please Call	Rear axle housing with brackets	\$1,450.00



DSE QUADRA-LINK™ REAR SWAY BAR

Fine tune your handling with this adjustable rear sway bar for DSE rear Quadra-Link suspensions. Includes bolt-on brackets. 1.00 or 1.125" diameter.

042203	1967-69 Camaro rear sway bar kit	\$384.95
042207	1970-81 Camaro rear sway bar kit	\$369.95

HEIDTS CAMARO PRO-G SUB-FRAME ASSEMBLY

This new 1968-74 bolt-on front sub-frame uses Heidt's new Pro-G™ suspension package for unbelievable cornering and overall handling. Simply unbolt and remove your front sheet metal, engine/trans, old sub-frame, then slide in the new complete sub-frame. All the sheet metal bolts back in place *There are many control arm, sway bar, shock and brake upgrades. Please call.*

The base kit includes: Pro-G sub-frame, Pro-G 2" dropped spindles, transmission x-member, tubular upper and lower arms, power rack and pinion steering, 11" Wilwood brakes with black calipers, billet coil-overs, single adjustable shocks with chrome springs,

CF-101	1967-69 Camaro.	\$7,029.00
CF-201	1970-81 Camaro.	\$7,039.00
SB-110	1" front sway bar	\$371.00
SB-401	1.25" Splined front sway bar	\$972.00





DSE REAR MINI-TUB KITS

Rear Mini-Tub kit moves the leaf springs in for more tire clearance. The kit includes: DSE deep tubs, rear upper shock crossmember, rear upper shock mounts, offset shackles, rear leaf springs, adjustable leaf spring pads, lower shock plates, U-bolts, mini-tub video, templates and detailed, installation instructions. You will need special DSE shocks and a narrowed fuel tank. 1970-81 kits also include special spring pockets and frame rail filler panels

041203	1967 Camaro, 2" drop	\$1,984.00
041204	1967 Camaro, 3" drop	\$1,984.00
041205	1968-69 Camaro, 2" drop	\$1,984.00
041206	1968-69 Camaro, 3" drop	\$1,984.00
041222	1967 Camaro, 2" drop	\$2,447.00
041205	1967 Camaro, 3" drop	\$2,447.00



DSE CAMARO SUB-FRAME CONNECTORS

Detroit Speed weld-in sub-frame connectors are fabricated from 2" x 3" x 0.120" wall rectangular steel tubing. Laser cut brackets attach to the rear of the sub-frame and rear frame rails. These sub-frame connectors fit tight to the floor and are barely visible from outside the car

010101	1967-69 Camaro	\$299.00
010103	1970-81 Camaro	\$299.00



HEIDTS 1968-72 CAMARO SUB-FRAME CONNECTORS

Completely bolt-on, with no cutting or floor modifications. Sub-frame connectors tie the front sub-frame into the rear spring mounts.

CF-107	1967-69 Camaro/Firebird	\$279.00
CF-110	1967-69 Camaro/Firebird convertible	\$312.00
CF-202	1970-82 Camaro/Firebird with factory suspension	\$279.00
RC-122	1970-82 Camaro/Firebird Heidt's Pro-G suspension sub-frame connectors	\$312.00



HEIDTS 1967-81 CAMARO REAR 4-LINK

Bolt-on maximum performance for your Camaro or Firebird. **The base kit includes:** chassis and axle brackets, adjustable links, full upper coil-over crossmember, panhard bar, adjustable HEIDTS coil-overs and all hardware. Completely bolt-on, with no cutting or floor modifications. Adjustable 4-link mounts allow suspension tuning. There are many brake, stainless steel and rear end housing upgrades. Please call. The driveshaft loop is optional and requires the sub-frame connectors.

RC-101	1967-69 Camaro/Firebird	\$2,060.00
RC-121	1970-81 Camaro/Firebird	\$2,060.00
RC-037	1967-69 driveshaft hoop	\$135.00
RC-125	1970-81 driveshaft hoop	\$149.00
SB-120	1967-69 rear sway bar	\$290.00
SB-170	1970-81 rear sway bar	\$290.00



HEIDTS PRO-G INDEPENDENT REAR SUSPENSION KIT FOR 1967 TO 73 CAMARO

The Heidts PRO-G IRS system will totally transform your Camaro. This is a bolt-in high-horsepower unit and includes sub-frame connectors that stiffen the body and locate the suspension. Included is a 9" Aluminum housing, posi-traction iron 3rd member, your choice of ratios, Wilwood 10.5" disc brakes, CV joint axles, billet adjustable coil-overs, crossmember and brackets, front pinion support and more. Track is 56.5". A parking brake kit is available. Please call.

IRC-101	1967-69 Camaro- plain rotors	\$12,800.00
IRC-101-S	with drilled and slotted rotors	\$13,200.00
IRC-102	1970-73 Camaro- plain rotors	\$12,800.00
IRC-102-S	with drilled and slotted rotors	\$13,200.00

Call 402.886.2275 or click: www.heinzmanstreetrods.com

1967-1981 Chevy Camaro Suspension

1967-1981 Chevy Camaro Suspension



DSE DEEP WHEEL TUBS

These three inches wider wheel tubs will accept monster tires. They are stamped from 18 gauge steel in the USA, fit perfect, look stock and save a ton of work. The Deep Tub's can be purchased as a pair or as part of the complete mini-tub kit:

- 040401 1967-69 Camaro deep tubs pair \$435.00
- 040403 1970-81 Camaro deep tubs pair \$535.00

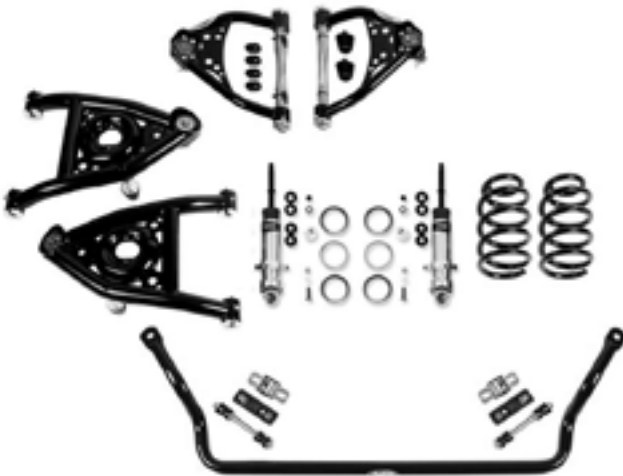

DSE CAMARO SPEED KITS

Detroit Speed's front suspension kits combine individual components into a system designed for your vehicle at three different levels. The DSE *Speed Kit 1* provides the ease of bolt-on components to improve your Nova's handling. The *Speed Kit 2* improves the handling performance to the next level and offers ride height adjustment.

Speed Kit 1: tubular upper control arms, tubular lower control arms, stock spring pocket, Koni classic front shocks, front 2" drop springs, front sway bar

Speed Kit 2: kit #1 with coil-over conversion kit, DSE tuned coil-over shocks, coil-over springs, and Torrington bearings

- 031301 1967-69 Speed kit 1 (specify SBC or LS) . . . \$2,453.00
- 031350 1967-69 Speed kit 2 (specify SBC or LS) . . . \$2,811.00
- 031307 1970-81 Speed kit 1 (specify SBC or LS) . . . \$2,508.95
- 031354 1970-81 Speed kit 2 (specify SBC or LS) . . . \$2,869.95



HEIDTS TUBULAR UPPER & LOWER CONTROL ARMS

Beef up your suspension and tighten your handling with Heidts tubular control arms. Both upper and lower arms are available in stock width or narrowed 1" per side. They come beautifully black powder coated, and are fitted with high performance urethane bushings and factory ball joints, ready to install in your chassis. The narrowed arms allow you to run wider tires, without rubbing the fenders. Lower arms are also available for coil-over shocks

- CA-301 68-72 Nova upper control arms \$650.00
- CA-301-N 68-72 Nova upper control arms-narrowed . . \$650.00
- CA-311 68-72 Nova lower control arms \$995.00
- CA-311-N 68-72 Nova lower control arms-narrowed \$995.00
- CA-311-M 68-72 Nova coil-over lower control arms . \$995.00
- CA-311-NM 68-72 Nova coil-over lower control arms . \$995.00
- 68-72 Nova coil-over lower control arms -narrowed \$995.00
- CC-064 Narrowed Tie Rod Ends for Narrowed Control Arms each \$29.95

HEIDTS TALL 2" DROPPED STEEL SPINDLE

The upper ball joint is raised 1-1/2" over the factory design to yield a better camber change during suspension movement. This corrects the excessive camber change of the original design. These spindles are steel, the strongest ones in the industry.

- SP-110 2" Dropped spindles pair \$470.00

QA1 COIL OVERS

Billet coil-over shocks have fully adjustable dampening. Silver powder coated full length progressive springs assure full travel and smooth ride with spring rates for small block and big block. They also fit stock lower arms using adapter kit CS-020.

- GS401 Coil-over shocks pr \$629.00
- 450# 10" Coil-over springs, smal block . . . included
- 550# 10" Coil-over springs, big block . . . included

Springs are available in 300-700 lb increments



SWAY BAR FOR STOCK NOVA SUB-FRAME

1-1/8" diameter stiffer sway bar for the stock sub-frame. Bolt-on.

- SB-069 1968-72 Nova, 67-69 Camaro sway bar . . \$314.00



GM-DELPHI 600 POWER STEERING GEAR

This all new steering gear replaces the common GM 800 series power steering gear used from 1964 to 1992. It uses low friction gear design and precision rack and pinion valve technology for increased steering feel. Quick ratio 12.7:1 and 6 lbs lighter than stock. Original power pitman arm may be used. A 3/4 x 30 spline rag joint and new o-ring power steering hoses are needed

- 090204 1967-1991 Camaro, ready to paint \$695.00
- 090204C 1967-1991 Camaro, Ceramic coated \$780.00
- 090205 Rag Joint, connects to stock column \$99.00
- 091202 Steering Hose Kits for 600 Gear Box. \$150.00



DSE ALUMINUM POWER STEERING PUMP

This pump is compatible with any power steering box or rack. These are new, not remanufactured pumps. They are available with a special flow control valve for Mustang II racks. Integral black plastic reservoir is included. Available polished, in cast iron, or without the reservoir for remote fill.

- 090901 Aluminum power steering pump w/res . . . \$275.00
- 090301 Aluminum power steering pump w/o res . . \$325.00
- 090801 6" V-belt PS pulley \$79.00

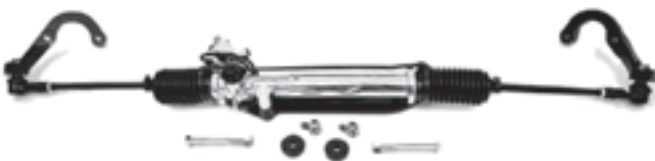

UNI-STEER RACK & PINION CONVERSION KIT

Uni-steer's Camaro rack and pinion will greatly improve handling and steering effort, while providing modern road feel. This kit is specifically designed for the Camaro's suspension, so there is no bump steer. Best of all, these are bolt-on kits, so no chassis modifications are necessary. Kit includes custom made rack & pinion mounted to bolt-on bracket, new bolt on steering arms (power rack kit only), all fittings, hardware, and complete installation instruction guide. Chrome racks are also available. Power racks work with the original PS pump.

- 8010540-01 1967-69 Camaro power rack & pinion kit . . \$890.00
- 8000770-01 1967-69 Camaro manual rack & pinion kit . \$646.92



T-56 TRANSMISSION CROSSMEMBER

This crossmember is specifically designed to mount a T-56 six-speed manual transmission in the proper location and add significant torsional stiffness to your car. The bolt in lower mount, allows easy removal of the transmission when required.

- 011201 1967-91 Camaro \$725.00
- 011202 Transmission mount \$45.00

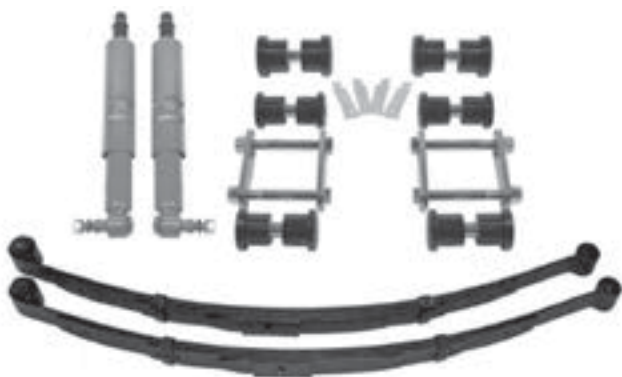

DSE REAR LEAF SPRING SUSPENSION KIT

This kit works great with any of the DSE front suspension systems. DSE leaf springs improve handling due to the increased spring rate and are available in either a 2 or 3" drop to lower ride height.

Kit includes: DSE rear leaf springs (2 or 3" drop), heavy duty shackle kit, Koni classic rear shocks. Specify 2 or 3" drop

- 041601 1967-69 Camaro multi-leaf spring \$915.00
- 041635 1970-81 Camaro multi-leaf spring \$915.00



DSE STAINLESS STEEL HEADERS

These DSE headers are designed and engineered for LS engines in the 1967-1969 Camaro/Firebird and 1968-74 Nova DSE Hydro-formed Subframe. The DSE Stainless Steel LS Headers feature a 1-7/8" primary tube diameter with 4-way merge collectors featuring V-Band clamps. Each header features a O2 sensor bung in the collector.

- 1967-1969 Camaro, 1968-1974 Nova \$2,350.00

Call 402.886.2275 or click: www.heinzmanstreetrods.com

1967-1981 Chevy Camaro Suspension

1967-1981 Chevy Camaro Suspension



62-74 CAMARO DISC KITS FOR DRUM BRAKE SPINDLES

This ECI brake kit bolts to the stock drum brake spindle with no machine work or spindle modifications, and does not move the wheels out. The kit uses stock big piston GM calipers and 11 inch GM rotors on special ECI billet hubs. Kit includes rotors, calipers with pads, bearings, seals, caliper mounting brackets, aluminum hubs and dust covers.

EC-723ACK 1967-69 Camaro \$800.00
Add \$100.00 for 13 in. rotors



HIGH-POWER ELECTRIC BOOSTER AND MASTER CYLINDER ASSEMBLY

This high pressure system includes an electric remote booster that can be mounted anywhere in the car. This cleans up the firewall, frees up extra valve cover clearance and solves the low vacuum problem that many high performance engines have. Good looking, light weight and easy to install. Features a 1.125" bore, dual circuits and built in metering/proportioning valve. Only 8" x 3.6" x 3.3".

10-56 Electric power brake booster/M.C. \$1,400.00



DB-111



DB-110

HEIDTS POWER BOOSTER & DUAL MASTER CYLINDER

Bolt-on kits for 1967-81 Camaros. *Kits include:* power booster, dual master cylinder and correct proportioning valve for disc-drum or disc-disc cars. Designed for use with our disc brake kits. Fully assembled and plumbed, ready for installation.

- DB-110 1967-69 Camaro booster and MC, disc/drum. . \$299.00**
- DB-110-D 1967-69 Camaro booster and MC, disc/disc . \$299.00**
- DB111 1967-69 Camaro manual MC, disc/drum. . . \$175.00**
- DB111-D 1967-69 Camaro manual MC, disc/disc. . . . \$175.00**
- DB-118 1970-81 Camaro booster and MC, disc/drum. . \$299.00**
- DB-118-D 1970-81 Camaro booster and MC, disc/disc. . \$299.00**

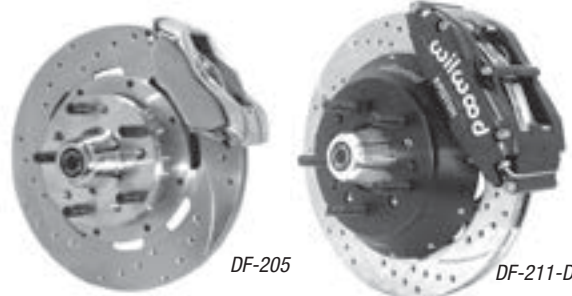

DF-205

DF-211-D

WILWOOD DISC BRAKE KITS

Four piston calipers, 11" rotors, 15" wheels, stock spindles

Wilwood's new limited offset FDL Pro-Series front hub kits for 1964-1974 Chevy II/Novas offer a disc brake upgrade for the original disc and drum spindles. Wheels are only +.19" from original drum brake position, and -.31" from the original disc brake position. This kit provides plenty of clearance inside popular 15" wheels and can be used with either manual or power boost master cylinders. Kits come complete forged billet Dynalite calipers, rotors, hub assembly, brackets and hardware. Requires purchase of additional brake lines.

- 140-15272 Black anodize calipers, un-drilled rotors . \$795.00**
- 140-10996 Black anodize, drilled & slotted \$1,042.00**

There are many color and finish options available

Six piston calipers, 14" rotors, 18" wheels, stock spindles

The ultimate in big brakes for extreme performance and show with 6 piston calipers and stagger vaned rotors. Use with either manual or power boost master cylinders. Kits come complete with calipers, rotors, hub assembly, brackets and hardware. Requires purchase of additional brake lines.

- 140-10920 Black anodize calipers, slotted rotors. . . . \$2,603.00**
- 140-10920D Black anodize, drilled & slotted rotors . . . \$2,738.00**

Wilwood Discs Brakes For Heidt's Dropped Spindles

- DF-205 11" drilled rotors, 4 piston polished calipers & hardware \$1,330.00**
- DF-205-D 11" drilled rotors w/ polished hubs, 4 piston polished calipers & hardware . . \$1,578.00**
- DF-210-D 12" drilled rotors w/ polished hubs, 4 piston polished calipers & hardware . . \$1,620.00**
- DF-211-D 13" drilled rotors w/ black hubs, 4 piston black calipers & hardware . . . \$2,896.00**



PRC ALUMINUM RADIATORS AND ASSEMBLIES

Beautifully made high-performance aluminum radiators made by Performance Rod & Custom. These custom made radiators are designed to cool big motors in extreme conditions or just cruising around. Just the radiator is available or as a complete assembly with a replacement core support and filler panels. Lots of extras are available such as electric fans, shrouds, A/C condensers and trans coolers. Please call.

- 2110067 Radiator/core support assembly, basic. . . \$695.00**

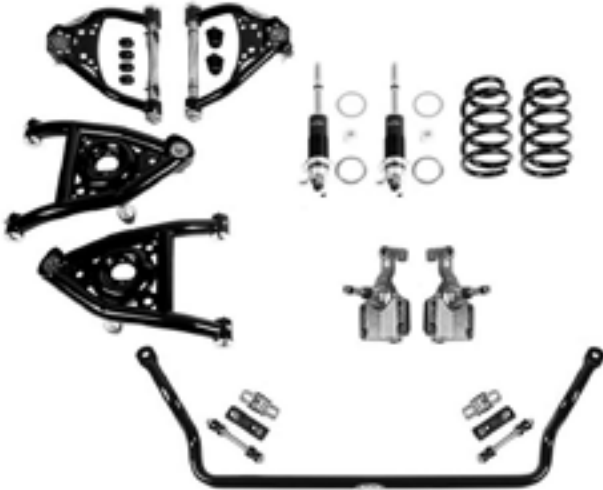

SPEED CONTROL ARM AND SPINDLE KIT

The Detroit Speed control arm and spindle kit is designed to work as an integrated system to improve handling. Detroit Speed's spindle is 1-1/2" taller than the stock spindle with 2" of drop. The taller spindle height modifies the camber curve resulting in a negative camber gain during suspension compression. The stock steer arms mount in the optimal location to minimize bump steer.

The tubular control arms provide increased strength and rigidity. They come with Delrin bushings, new ball joints and have a gloss black powder coat finish. Upper control arms are designed with additional positive caster and include the cross shaft. The lower control arms feature a robust tubular design with gussets and a cross brace.

030104	1964-66, A-Body	\$2,295.00
030105	1967-72, A-Body	\$2,295.00

DSE CHEVELLE/GM A-BODY SPEED KITS

Detroit Speed's front suspension kits combine individual components into a system designed for your vehicle at three different levels. The DSE *Speed Kit 1* provides the ease of bolt-on components to improve your A-Body's handling. The *Speed Kit 2* improves the handling performance to the next level and offers ride height adjustment.

Speed Kit 1: tubular upper control arms, tubular lower control arms with stock spring pocket, Koni classic front shocks, DSE increased spring rate springs, DSE forged 2" dropped spindle DSE tubular sway bar.

Speed Kit 2: Kit #1 with single adjustable DSE coil-over conversion kit, DSE splined tubular sway bar, shock spanner tool

031309	1964-66, Speed kit 1	\$2,922.00
031310	1967, Speed kit 1	\$2,922.00
031311	1968-72, Speed kit 1	\$2,922.00
031317	1964-66, Speed kit 2	\$3,280.00
031321	1967, Speed Kit 2	\$3,280.00
031318	1968-72, Speed kit 2	\$3,280.00

All kits: must specify, SBC or LS



A-BODY COIL SPRINGS

Give your A-Body a modern Pro-Touring stance while improving ride and handling with DSE A-Body coil spring kits. Available in either stock ride height or a 2" drop (from stock). Rear springs give a 1-1.5" drop.

031109	1964-66, Stock (specify SB, BB, LS) . . . pair	\$285.95
031111	1968-72, Stock (specify SB, BB, LS) . . . pair	\$285.95
031109	1964-66, 2" drop (specify SB, BB, LS) .. pair	\$285.95
031111	1968-72, 2" drop (specify SB, BB, LS) .. pair	\$285.95
041802	1964-66, Rear, 1.25-1.5" drop pair	\$285.95
041804	1967-72, Rear, 1" drop pair	\$285.95

A-BODY FRONT REPLACEMENT SHOCKS

These Koni Classic rebound adjustable shocks bolt-in the stock location. They use the latest in shock absorber technology to give your car a modern feel while maintaining comfortable ride characteristics.

031007	1964-72, Stock front shocks pair	\$165.95
041306	1964-72, Stock rear shocks pair	\$165.95



1964-1972 Chevy Chevelle Suspension

1964-1972 Chevelle suspension



DSE A-BODY SWAY BARS

DSE's tubular 1-3/8" front sway kit provides a dramatic improvement on cars with stock suspension and optimal improvement on cars fitted with other DSE components. Kit includes sway bar, greaseable polyurethane bushings, mounts and end links.

The splined sway bar kit is tuned to provide the ultimate in performance, ride, and handling. It uses a 1-1/2" OD hollow 4130 alloy heat-treated splined sway bar, black hard coated 6061-T6 billet aluminum pillow blocks with Delrin bushings, 3/4" thick solid steel sway bar arms, low-friction ball style end-link system. Bolt-on 1968-72 A-Bodies; 1964-66 A-Body sway bar mounting holes need to be drilled and tapped up to 3/8".

- 031403 1964-67, Tubular sway bar \$299.00
- 031402 1968-72, Tubular sway bar \$299.98
- 031404 1964-72, Splined sway bar kit \$1,036.00

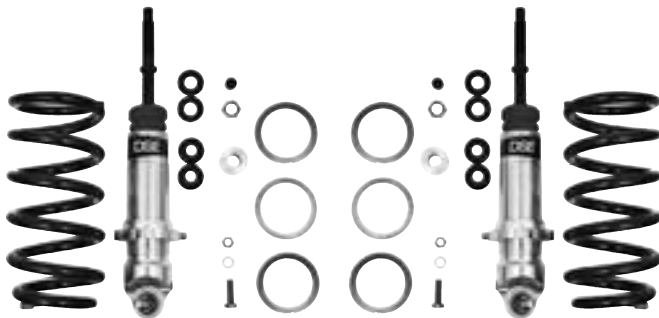

DSE FRONT COIL-OVER KIT

Now you can bolt the latest coil-over spring/shock technology to any GM A-Body. The specific DSE valving will bring your classic's handling and ride into the 21st century. The base coil-over package offers extensive ride height adjustment and special DSE valving. Optional double adjustable coil-overs offer both compression and rebound tuning. The monotube remote reservoir coil-over set is the ultimate package and offers separate fluid canisters for optimum adjustability, 1" more stroke and improved heat dissipation.

- 030306 1964-72, A-Body (specify SB, BB, LS). . . \$1,565.00
Call for pricing on shock options



HEIDTS GM A-BODY CONTROL ARMS

HEIDTS tubular upper and lower control arms for the 1964-72 Chevelle and all other GM A-body cars are state of the art in both design and fabrication. Uppers are 1-1/4" dia. tube, and the lowers are a full 1-1/2" tube. They are powder coated and completely assembled with ball joints and urethane bushings. High performance urethane bushings tighten up the suspension and allow no deflection under cornering loads for absolutely solid, positive handling. Upper arms include offset cross shafts for easier alignment and adjustment of caster settings.

- CA-401 1964-72 A-Body upper control arms \$650.00
- CA-411 1964-72 A-Body lower control arms \$995.00
- CA-411-M 1964-72 Coil-over lower control arms. . . \$995.00

Heidt's Pro-G dropped spindles (SP-110) are recommend with our control arms.

HEIDTS TALL 2" DROPPED STEEL SPINDLE

The upper ball joint is raised 1-1/2" over the factory design to yield a better camber change during suspension movement. This corrects the excessive camber change of the original design. These spindles are STEEL, the strongest ones in the industry.



- SP-110 2" Dropped Spindles pair \$470.00

QA1 COIL OVERS

Billet coil-over shocks have fully adjustable dampening. Silver powder coated full length progressive springs assure full travel and smooth ride with spring rates for small block and big block. They also fit stock lower arms using adapter kit CS-020.



- GS401 Coil-over shocks pr \$629.00
- 450# 10" Coil-over springs, smal block. . . included
- 550# 10" Coil-over springs, big block . . . included

Springs are available in 300-700 lb increments

- CQ-010 Thrust bearings for coil-over shocks \$35.00
- TA-001 Spanner wrench \$15.00



HEIDTS A-BODY SWAY BARS

Completely bolt-on with the supplied hardware.

- SB-071 1964-72 1-1/8" Chevelle front sway bar . . \$314.00
- SB-150 1964-72 1" Chevelle rear sway bar** . . . \$314.00

**Must use HEIDTS rear 4-Link package



GM-DELPHI 600 POWER STEERING GEAR

This all new steering gear replaces the common GM 800 series power steering gear used from 1964 to 1992. It uses low friction gear design and precision rack and pinion valve technology for increased steering feel. Quick ratio 12.7:1 and 6 lbs lighter than stock. Original power pitman arm may be used. A 3/4 x 30 spline rag joint and new o-ring power steering hoses are needed

- 090204** 1964-72 A-Body, ready to paint **\$695.00**
- 090204C** 1964-72 A-Body, Ceramic coated **\$780.00**
- 090205** Rag Joint, connects to stock column **\$99.00**
- 091202** Steering hose kits for 600 gear box. **\$215.00**



HEIDTS CHEVELLE REAR 4-LINKS

Tighten up the handling of your A-Body by eliminating the stock suspension flex. These upper links are adjustable, 1-1/4" dia. tube, and the lowers are a full 1-1/2" x 2" square tubing. They're powder coated black and are supplied with greaseable swivel and fixed high performance urethane bushings installed. Urethane bushings tighten up the suspension and the swivel ends allow roll deflection under cornering loads for absolutely solid, positive handling. Completely assembled and includes all new hardware.

- RC-240** 1964-66 GM A-Body rear 4-link **\$618.00**
- RC-250** 1967-72 GM A-Body rear 4-link **\$618.00**

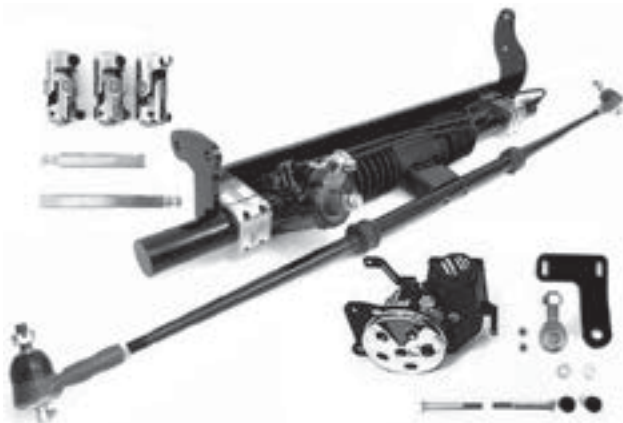

UNI-STEER POWER RACK & PINION CONVERSION

Sharpen up the lack luster steering in your classic Chevelle and A-Bodies. This rack and pinion kit greatly improves the handling and steering response, without having to chop or modify your stock frame. This kit improves the stock geometry, eliminating the bump steer found in the stock suspension. Kit is complete with pump assembly and steering shaft.

- 8010780-01** 1964-67 A-Body power rack & pinion kit . . **\$1,747.00**
- 8010740-01** 1968-72 A-Body power rack & pinion kit . . **\$1,747.00**



HEIDT'S REAR CHASSIS BRACE LINKS

These links tie the upper frame mount of the rear 4-links to the chassis crossmember to eliminate flex. They take the added stress from the new rear 4-links. Sold in pairs.

- RC-255** 1964-66 GM A-Body **\$140.00**
- RC-251** 1967-72 GM A-Body **\$140.00**

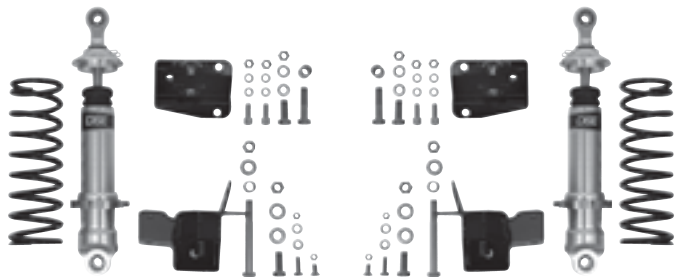

DSE REAR COIL-OVER KIT

Bolt the latest coil-over spring/shock technology to any GM A-Body. The base coil-over package offers extensive ride height adjustment and special DSE valving that will bring your classic's handling and ride into the 21st century. Optional double adjustable coil-overs offer both compression and rebound tuning. For the ultimate, use the monotube remote reservoir coil-over set with separate fluid canisters for optimum adjustability, 1" more stroke and improved heat dissipation. Kit includes, springs, shocks and brackets.

- 042410** 1964-66, A-Body. **\$1,351.95**
- 042411** 1967, A-Body. **\$1,351.95**
- 042411** 1968-72, A-Body. **\$1,351.95**

Call for pricing on shock options



DSE ALUMINUM POWER STEERING PUMP

This pump is compatible with any power steering box or rack. These are new, not remanufactured pumps. Integral black plastic reservoir is included. Available polished, in cast iron, or without the reservoir for remote fill.

- 090901** Aluminum power steering pump w/res . . . **\$276.00**
- 090301** Aluminum power steering pump w/o res . . **\$276.00**
- 090801** 6" V-belt PS pulley **\$79.00**

Call 402.886.2275 or click: www.heinzmanstreetrods.com

1964-1972 Chevelle Suspension

1964-1972 Chevelle Suspension



DSE REAR SPEED KITS

Our Speed kits are designed to provide optimum geometry and tire contact through the full range of rear suspension travel. With Swivel Links™, the rear end housing becomes fully articulated, without the use of noisy spherical heim joints. The tubular rear sway bar attaches to the chassis for a substantial improvement in cornering ability. The rear Speed Kit springs, shock absorbers and sway bars are designed to complement the front DSE Speed Kits, giving your A-Body handling and ride quality on par with the latest modern muscle cars.

Speed Kit 1: includes: patented Swivel-Link™ rear control arms and DSE chassis brace kit

Speed Kit 2: includes Kit 1, plus: DSE rear coil springs, Koni classic shock absorbers, DSE tubular rear sway bar

Speed Kit 3: includes all of the above and replaces the stock style springs and shocks with DSE specific rear coil-over shocks & springs

041603	1964-67, Speed kit 1.....	\$1,209.00
041604	1968-72, Speed kit 1	\$1,198.00
041607	1964-66, Speed kit 2.....	\$2,195.00
041609	1967, Speed Kit 2	\$2,195.00
041608	1968-72, Speed kit 2.....	\$2,195.00
041611	1964-66, Speed kit 3.....	\$2,932.00
041613	1967, Speed Kit 3	\$2,932.00
041612	1968-72, Speed kit 3.....	\$2,811.95



DSE TUBULAR REAR SWAY BAR

The DSE 1-1/8" tubular steel rear sway bar offers many advantages over the non-effective stock rear bar. DSE's bar attaches to the rear end housing and to the chassis crossmember, not the lower control arms like the OEM set-up. The DSE bar mounts to the chassis with Swivel-Links™ (Patented), eliminating binding through the range of rear suspension travel. The bar comes powder coated in a high gloss black finish and includes all necessary mounting hardware.

042201 1964-72 Rear sway bar kit..... \$403.95

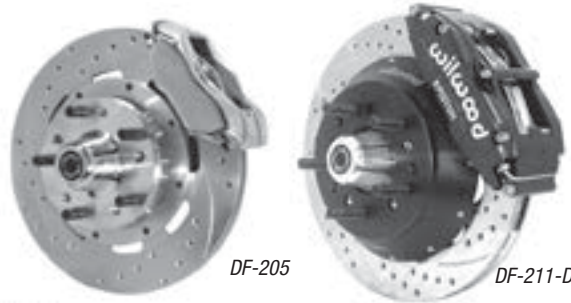

WILWOOD DISC BRAKE KITS

Four piston calipers, 11" rotors, 15" wheels, stock spindles .19" wheel offset

Use with either manual or power boost master cylinders. Kits come complete forged billet Dynalite calipers, rotors, hub assembly, brackets and hardware. Requires purchase of additional brake lines.

- 220-7056 Black anodize calipers, un-drilled rotors . \$795.00
- 220-7056 Black anodize, drilled & slotted \$1,042.00

There are many color and finish options available

Six piston calipers, 14" rotors, 18" wheels, stock spindles

The ultimate in big brakes for extreme performance and show. Manual or power boost master cylinders. Kits come complete with calipers, rotors, hub assembly, brackets and hardware.

- 140-10920-d Black anodize calipers, slotted rotors \$2,738.00
- 220-7056 Black anodize, drilled & slotted rotors . \$2,738.00

Wilwood Discs Brakes For Heidt's Dropped Spindles

- DF-205 11" drilled rotors, 4 piston polished calipers & hardware \$1,330.00
- DF-205-D 11" drilled rotors w/ polished hubs, 4 piston polished calipers & hardware .. \$1,578.00
- DF-210-D 12" drilled rotors w/ polished hubs, 4 piston polished calipers & hardware .. \$1,620.00
- DF-211-D 13" drilled rotors w/ black hubs, 4 piston black calipers & hardware . . . \$2,896.00



HEIDTS POWER BOOSTER & DUAL MASTER CYLINDER

Bolt-on kits for 1967-81 Camaros. *Kit includes:* power booster, dual master cylinder and correct proportioning valve for disc-drum or disc-disc cars. Designed for use with our Disc Brake Kits. Fully assembled and plumbed, ready for installation.

- DB-114 1964-66 A-Body booster w/mc for disc/drum . . \$299.00
- DB-114-D 1964-66 A-Body booster w/mc for disc/disc . . \$299.00
- DB-115 1967-72 A-Body manual master for disc/drum . \$175.00
- DB-115-D 1967-72 A-Body manual master for disc/disc . . \$175.00

IMPORTANT! UNIVERSAL APPLICATIONS

The customer is responsible for determining the suitability of these parts. Any needed modification to the parts or car is completely at the discretion of the owner and/or installer.



REAR SPRING MOUNTS

These frame brackets mount Chassis Engineering Slider Springs. Kit includes right and left front and rear spring hanger brackets. Requires welding

AS-0010 Rear spring mounts. \$115.00



REAR END MOUNTING KIT

This universal kit includes the above spring mounts with (4) U-bolts with nuts, specially valved shocks, shackles, lower shock mounts (upper not furnished) and Chassis Engineering Slider Springs. Fitting and welding is required.

AS-0010C Rear end mounting kit \$912.00

Options For Rear End Mounting Kit

- Please specify type of rear end used.
- Specify type of spring, "REGULAR" for normal usage or "HEAVY DUTY" for heavier loads such as sedan delivery. Add \$20.00 for heavy duty spring option.
- Kit comes with specially valved shocks, or if you prefer, gas shocks, if so then state "GAS SHOCK OPTION" and add \$18.00.



STEEL MONO LEAF SPRINGS

Meets or exceeds multi leaf specifications and is only 5/8" thick at the center. It comes with spacers so that it will fit your crossmember and "U" bolts. These spacers may be arranged in different combinations—either above or below the spring. This allows fine tuning of the height of your car in 1/8" increments up to about an inch.

1928-34 Ford Front Spring \$195.00



LEAF SPRING BUTTON SLIDERS

Make your leaf spring into a "Slider". Buttons snap into hole drilled in each spring end. Springs can be drilled by use of slow drill (100 RPM or less).

AU-2060 1-3/4" round slider each \$0.75
 AU-2061 2-1/4" round slider each \$0.75



FRONT AND REAR SWAY BARS

This is an excellent way to improve the handling and overall drive-ability of the top-heavy 30s and 40s cars. Eliminates road sway. For best results, use front and rear bars together. Linkage and mounting hardware furnished. Upper linkage mount must be fabricated. If using a Chassis Engineering rear mounting kit, specify axle housing diameter. Front kit fits many stock width Pinto/Mustang IFS kits and swaps.

SB-0037R Rear sway bar kit \$195.00
 SB-0010PM Front sway bar kit \$210.00



BULKHEAD FITTINGS

Takes the brake line thru the frame rail instead of around it. Stainless Steel with 1/8" pipe fittings on both ends.

AU-0071 Bulkhead Fittings- for 2" thick frame rail . . \$45.00



NO. 3 STAINLESS STEEL BRAKE LINES

AU-0014 12" \$18.00
 AU-0016 15" \$19.00
 AU-0018 18" \$20.00
 AU-0022 22" \$22.00

Fatman Mustang II sub-frames and suspension

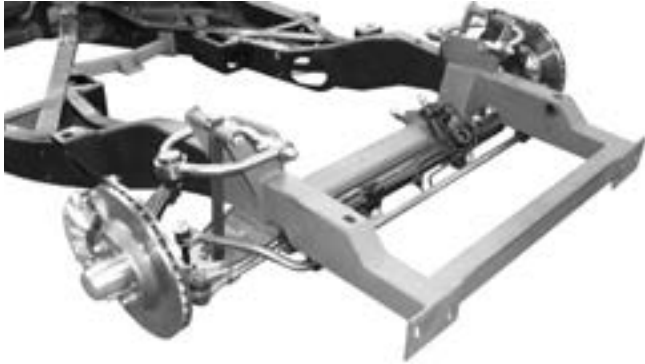

FATMAN MUSTANG II FRONT STUBS

Some cars have a frame design which doesn't allow for a simple Mustang II crossmember installation, yet are too narrow for a GM sub-frame. Fatman builds these weld-on clips which provide a 2-4" drop, and include pre-made mounts for bumpers, radiators and front sheet metal. Stock sheet metal remounts with very minor, or no trimming required. Many applications are available. Please call for details.

1934-59 Buick, 34-56 Olds, 37-58 Pontiac, 34-68 Cadillac, 37-70 Chevy, 64-72 Chevelle, 34-55 Chrysler/DeSoto, 34-56 Dodge/Plymouth, 49-63 Ford, 40-54 Hudson, 49-56 Mercury.

- Stub crossmember only starting at\$1,250.00
- Complete kit with stock springs\$3,450.00
- Complete kit with coil overs\$3,995.00



FATMAN MUSTANG II HUB-TO-HUB KITS

All needed components can be purchased in kit form as shown above. Most kits include coil-over or stock springs and shocks, sway bar, stainless steel tubular control arms, manual rack and pinion, spindles and big brake kits with bearings/seals. Can also be ordered with a Fatman crossmember. Huge selection of crossmembers for everything from Buicks to Willys.

- Crossmember with stock spring package \$2,560.00
- Crossmember with coil-over package \$2,995.00



FATMAN 1949 AND UP DROPPED UPRIGHTS

Many 1949 and up cars have an excellent original IFS that can be modified with dropped uprights and late model brakes. New dropped uprights provide a relatively simple way to lower your car while maintaining proper geometry, alignment and suspension travel. One to three inch drop. Many applications available. Sold by the pair. Please call.

- 1939-54 Chevy, 53-62 Corvette \$395.00
- 1949-53 Ford \$470.00
- 1954-56 Ford, 52-57 Lincoln, Merc. \$450.00
- 1955-57 T-Birds \$535.00
- 1965-73 Mustang and Cougar, 1963-71 Falcon and Fairlane \$580.00
- 1937-56 Buick, 39-56 Olds, 37-57 Pontiac \$395.00

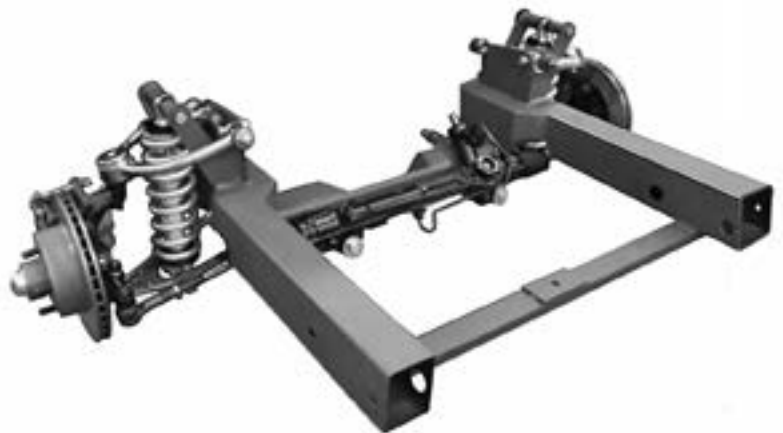

FATMAN 1949-51 FORD/MUSTANG II FRONT STUB

Just weld this complete front clip to your original frame. You'll get a 3"-5" drop with all modern suspension, steering, and brakes. Core support and bumper mounts are built in so sheet metal bolts right back up. Flatheads will not fit. All year Chevy small blocks fit well. Ford engines will need a dual sump oil pan. Both will need the transmission tunnel raised. Mustang II parts and tubular motor mounts are optional.

1949-51 Ford/Mustang II stub frame only from \$1,750.00



MUSTANG II SUSPENSION PACKAGES

Mustang II suspension packages are available in deluxe and standard versions. Deluxe comes with tubular upper and lower A-arms and standard comes with stamped OEM style A-arms. Package comes complete with upper and lower A-arms, spindles, springs, shocks, rack and pinion steering gear, tie rod ends, rotors, calipers, caliper mounts, and bearings and seals.

Deluxe, 11" brakes \$2,200.00
Add \$500.00 for crossmember kit

There are many spring/shock, control arm, brake and rack options that can be substituted for the basic parts included above. Please call for best packages.

COIL-OVER SHOCKS FOR MUSTANG II SUSPENSION

Coil-Over Shocks for Mustang II IFS Kits from QA-1. Fits stock Mustang II lower arms and Heidt's Tubular Coil-Over Lower Arms. Provides the ultimate in hi-tech appearance for the Mustang II IFS. Provides adjustable ride height as well as spring rates. Adjustable aluminum shocks, with aluminum ride height adjusters, spherical lower ends and powder coated springs included.

- MS-300 Coil-Over Shocks** pair **\$525.00**
- Coil-Over Springs** pair **\$125.00**
- Weight- less than 1350 375 lb. spring
- Weight- 1350-1525 500 lb. spring
- Weight- 1525-1700 600 lb. spring
- Weight- 1700 plus 700 lb. spring
- TA-002 Spanner Wrench** **\$20.00**



MUSTANG II 2" DROPPED SPINDLE

High quality, heat treated 1045 alloy steel. 2" drop design.

- AU-0220** pair **\$239.95**
- AU-2070 stock height** pair **\$239.95**
- Bearings and seals** ...pr **\$15.95**



TUBULAR UPPER AND LOWER A-ARMS

Heidt's tubular control arms are TIG welded and fully assembled with bushings, ball joints and cross-shafts. Available in plain steel or polished stainless. The upper arm is a direct replacement for the stock upper A-Arms.

The lower tubular control arms are designed to use the stock style coil springs and shocks. The stronger GM style "A-Arm" design does not use the original strut rod for a cleaner appearance. Includes sway bar mounts. Must be used with the correct longer sleeve and gusset.

- CA-101 Plain steel upper control arms** **\$387.00**
- CA-101-SS Polished stainless steel upper control arms** **\$845.00**
- CA-103-S Plain steel lower control arms** **\$653.00**
- CA-103-SS-S Polished stainless steel lower** **\$1,714.00**

NOTE: Narrowed upper/lower sets available



COIL-OVER LOWER ARMS

Heidt's lower A-Arms will accept any standard aftermarket coil-over shock. Available in mild steel or polished stainless steel for the ultimate in appearance. Assembled with bushings and ball joints.

- CA-103-M Plain steel** . **\$653.00**
- CA-103-SS-M Polished Stainless Steel** **\$1,714.00**

Mustang II Suspension Parts

MUSTANG II STOCK REPLACEMENT PARTS



UPPER BALL JOINT
MP-015 each \$59.00



UPPER ARM BOLT KIT
MP-001-A \$30.00



FOX BODY MUSTANG RACK AND PINION
Manual, new \$289.00 Power, Uni-steer \$710.00
Tie Rod Ends..... each \$30.00



LOWER BALL JOINT
MP-016 each \$60.00



BASIC BOLT KIT
MP-001 \$38.00
Includes bolts MP-001-A



LOWER ARM BUSHINGS
MP-014 pair \$28.00



STEERING RACK BUSHINGS
MP-012 pair \$37.00



UPPER CONTROL ARM BUSHINGS
MP-013 pair \$26.95



CALIPER BOLT KIT
MP-002 pair \$16.00



SPINDLE NUT KIT
HK-006 pair \$26.00



STRUT ROD BUSHING KIT
MP-011 pair \$35.00



REPLACEMENT COIL SPRINGS
These springs are shorter than stock.

FS-8250	250 pound ..	\$129.00
FS-8275	275 pound ..	\$129.00
FS-8300	300 pound ..	\$129.00
FS-8325	325 pound ..	\$129.00
FS-8350	350 pound ..	\$129.00
FS-8375	375 pound ..	\$129.00



TIE ROD ENDS
MP-017 each \$34.00



STABILIZER BAR BRACKET KIT
Bracket kit bolts onto existing control arms, with an easy-to-use drill template, or bolts onto Heidt's control arms. Available in plain or polished stainless steel.

SB-010	Original	\$24.95
SB-012	Heidt's	\$24.95
SB-012SS	Heidt's SS	\$24.95



OEM STYLE CONTROL ARMS
Upper and lower set . \$299.00



SPRING SPACERS
Use these 3/4" thick spacers in place of your upper spring cushions to add just a little ride height back in your ride. Sold in pairs.

MP-060 \$45.00



UPPER SPRING CUSHIONS
MP-006 pair \$28.00



ORIGINAL SHOCKS
OEM SHOCKS pair \$95.00
QA-1 Adjustable .. pair \$355.00



ECONOMY MUSTANG II DISC BRAKES
11" FORD ROTORS pair . \$130.00
GM CALIPERS/ PINS/ PADS pair \$89.95
BRACKET KIT \$100.00



ECONOMY MUSTANG II DISC BRAKES
11" FORD ROTORS pair . \$130.00
GM CALIPERS/ PINS/ PADS pair \$89.95
BRACKET KIT \$100.00

CALL FOR CURRENT PRICES



AMERICAN RACING TORQUE THRUST "D"

Series 605- chrome

14" x 6"\$320.00
15" x 6"\$320.00
15" x 7"\$330.00
15" x 8"\$350.00
16" x 8"\$370.00



AMERICAN RACING TORQUE THRUST "D"

Series105- Gun Metal -mach. lip

14" x 6"\$170.00
15" x 6"\$165.00
15" x 7"\$175.00
15" x 8"\$195.00
16" x 8"\$225.00



HALIBRAND POLISHED 5 SPOKE

15" x 6"\$220.00
15" x 7"\$229.00
15" x 8"\$242.00

Mag-Coat with polished lip also available.



WHEEL SMITH STEEL WHEELS

GENNIE

Bare steel, trim rings and hub caps not included. 15 and 16" sizes, many widths available. 15x6 & 15x7 (set 4)\$640.00

SMOOTHIE

Bare steel, trim rings and hub caps not included. 15x6 & 15x7 (set 4) ...\$550.00

STAINLESS STEEL TRIM RINGS

14", 15", 16" each \$35.00

STAINLESS STEEL HUB CAPS

..... each \$55.00



AMERICAN RACING SHELBY COBRA

Series 427 Painted w/polished rim. Special order only.

15" x 7"\$345.00
17" x 8"\$425.00
18" x 9.5"\$430.00

Also available all polished



AMERICAN RACING VINTAGE T70R

Series T70R Gun Metal w/mach. lip

15" x 5"\$220.00
15" x 7"\$235.00
15" x 8"\$245.00
17" x 8"\$275.00



HALIBRAND SPRINT

Cast- fully polished

15" x 6"\$339.00
15" x 7"\$349.00
15" x 8"\$425.00



AMERICAN RACING SALT FLAT

Series 470 Gun Metal w/polished rim. Special order only.

15" x 6"\$275.00
15" x 7"\$275.00
17" x 8"\$355.00

Also available fully polished

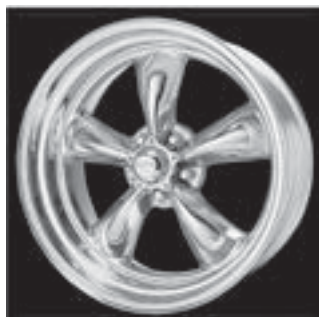

AMERICAN RACING TORQUE THRUST II

Fully Polished

15" x 6"\$235.00
15" x 7"\$250.00
16" x 8"\$270.00
17" x 8"\$325.00



AMERICAN RACING TORQUE THRUST II

Painted with polished rim

15" x 6"\$235.00
15" x 7"\$250.00
16" x 8"\$270.00
17" x 8"\$325.00



ORIGINAL FORD STYLE HUB CAPS & TRIM RINGS

For original style wheels. Polished stainless steel hub caps have all the details of the originals. Priced each.

VIN01C1130	1940 Std	
	1940-41 P.U. . .	\$55.00
VIN21A1130	1942-48 Pass	
	1956 P.U.	\$55.00
VIN6A18303	Trim Rings	
	15 inch.	\$55.00

Most wheel designs have many sizes, bolt circles, backspacing, offsets and finishes available. Please call for more info.

Call 402.886.2275 or click: www.heinzmanstreetrods.com

American Racing, Halibrand, wheel vintiques custom wheels



SUPERBELL POWER STOPPER DISC BRAKE KIT

Designed for 3000 lb. cars and heavier. Fits 1939-48 Ford passenger car or Chassis Engineering reproduction spindles and 1948-56 Ford pickup spindles. Includes: brackets, bearings, seals, hardware, backing plates, hubs, rotors, calipers. Specify bolt pattern, 4-1/2", 4-3/4", 5", or 5-1/2".

1135 1939-48 Ford car, 1948-56 Ford Pickup .. \$749.95



SUPERBELL BASIC HOT ROD DISC BRAKE KIT

Adapts a wide range of rotors and GM 1978-86 intermediate (metric) calipers to 1939-48 Ford passenger car or Chassis Engineering reproduction spindles and 1948-56 Ford pickup spindles. Includes: brackets, bearings, seals, hardware, rotors, calipers. Specify bolt pattern, 4-1/2" or 4-3/4".

**1125K 1939-48 Ford car, 1948-56 Ford Pickup
Basic Brake kit \$469.00**

1125 Basic Brake kit, brackets/bearings only .. \$195.00



LOW BUCK BRAKE KIT

Adapts most 1970-77 intermediate GM calipers and rotors to 1937-48 Ford spindles. No machining is required.

Low Buck Brake Kit. \$125.00



ECI DISC BRAKE KITS FOR STOCK SPINDLES

ECI's Disc Brake kits bolt-on to stock or reproduction spindles. Kits include: GM full size car calipers/pads (bigger than the GM intermediate calipers), Factory 11" rotors with Ford or GM bolt pattern, bearings/adapters, seals, hardware, brackets and instructions. Available as brackets, bearings and hardware only or complete with rotors and loaded calipers

1937-48 FORD CARS / 37-47 FORD P/U

EC-701 GM 4-3/4" Bolt CircleBasic Kit \$160.00

EC-701CK Complete Kit \$425.00

EC-709 FORD 4-1/2" Bolt Circle.....Basic Kit \$160.00

EC-709CK Complete Kit \$450.00

EC-730 FORD 5-1/2" Bolt Circle.Basic Kit \$160.00

EC-730CK Complete Kit \$450.00

NOTE: Aftermarket spindles require modified steering arms.

1948-56 FORD PICKUP (1/2 TON)

EC-705 GM 4-3/4" Bolt CircleBasic Kit \$160.00

EC-705CK Complete Kit \$450.00

EC-710 FORD 4-1/2" Bolt Circle.....Basic Kit \$160.00

EC-710CK Complete Kit \$450.00

EC-731 FORD 5-1/2" Bolt Circle.Basic Kit \$160.00

EC-731CK Complete Kit \$450.00

1957-64 FORD PICKUP (1/2 TON)

EC-732 FORD 5-1/2" Bolt Circle.....Basic Kit \$160.00

EC-732CK Complete Kit \$450.00

1949-53 FORD, 53-53 MERCURY

EC-721 GM 4-3/4" Bolt CircleBasic Kit \$170.00

EC-721CK Complete Kit \$425.00

EC-721F FORD 4-1/2" Bolt Circle.....Basic Kit \$230.00

EC-721FCK Complete Kit \$450.00

1954-56 FORD/MERC, 55-57 T-BIRD

EC-733 FORD 4-1/2" Bolt Circle.....Basic Kit \$275.00

EC-733CK Complete Kit \$450.00

1957-64 FORD/MERCURY

EC-734 FORD 4-1/2" Bolt Circle.....Basic Kit \$275.00

EC-734CK Complete Kit \$450.00

1965-70 MUSTANG

EC-737CK FORD 4-1/2" Bolt Circle..... Complete Kit \$575.00

1949-54 CHEVY PASSENGER CAR AND 53-62 CORVETTE

EC-702 GM 4-3/4" Bolt CircleBasic Kit \$180.00

EC-702CK Complete Kit \$450.00

1937-40 CHEVY PASSENGER CAR with original I.F.S.

EC-707 GM 4-3/4" Bolt CircleBasic Kit \$180.00

EC-707CK Complete Kit \$450.00

1941-48 CHEVY PASSENGER CAR with original I.F.S.

EC-706 GM 4-3/4" Bolt CircleBasic Kit \$180.00

EC-706CK Complete Kit \$450.00

1937-40 CHEVY PASSENGER CAR AND PICKUP with Straight Axle

EC-711S GM 4-3/4" Bolt CircleBasic Kit \$180.00

EC-711SCK Complete Kit \$450.00

1941-54 CHEVY PASSENGER CAR AND PICKUP with Straight Axle

EC-711 GM 4-3/4" Bolt CircleBasic Kit \$180.00

EC-711CK Complete Kit \$450.00

Hot Rod Front Disc Brake Kits

ECI DISC BRAKE KITS FOR STOCK SPINDLES (cont.)

- 55-58 CHEVROLET PASSENGER CARS** with stock spindles
- EC-708 GM 4-3/4" Bolt Circle Basic Kit **\$175.00**
 EC-708CK Complete Kit **\$450.00**
 EC-708ACK Alum Hub, zero offset Complete Kit **\$575.00**
- 59-64 CHEVY PASSENGER CAR**
- EC-712 GM 4-3/4" Bolt Circle Basic Kit **\$175.00**
 EC-712CK Complete Kit **\$450.00**
 EC-712ACK Alum Hub, zero offset Complete Kit **\$575.00**
- 65-68 Chevy passenger car**
- EC-729 GM 4-3/4" Bolt Circle. Basic Kit **\$175.00**
 EC-729CK Complete Kit **\$450.00**
 EC-729ACK Alum Hub, zero offset Complete Kit **\$575.00**
- 55-59 Chevy Pickup**
- EC-711X GM 4-3/4" Bolt Circle Basic Kit **\$180.00**
 EC-711XCK Complete Kit **\$450.00**



WILWOOD FRONT DISC BRAKE KITS Forged Dynalite Pro Series Front Brake Kit 4 pistons, 11" rotors

FDL Pro-Series Front Hub Kits offer complete disc brake upgrade solutions for muscle cars, street rods, and 50s cars. Based on the forged billet Dynalite caliper, these require no modifications for installation, and provide plenty of clearance inside popular 15" wheels. FDL Pro-Series kits can be used with either manual or power boost master cylinders. Black anodized calipers, solid rotors standard. Optional caliper finishes and drill/slotted rotors available.

- 140-11491 1955-57 Chevy. **\$958.00**
 140-11811 1949-1954 Chevy/ 1953-1962 Corvette ... **\$944.00**
 140-11017 1971-18 Mustang II. **\$944.00**
 140-11013 1937-48 Ford Spindle (polished optional) . **\$944.00**
 140-11099 1980-1987 GM G-Body, Malibu, Buick GN . **\$944.00**
 140-10996 1967-69 Camaro, 1964-1974 A-Body. **\$944.00**
 140-11007 1970-78 Camaro / Firebird **\$944.00**
 140-11012 1982-90 Camaro / Firebird **\$944.00**



JOHN'S INDUSTRIES REAR DRUM BRAKE KIT

These rear drum brakes are assembled and ready to install. Fits the popular "Torino" style flanges. Available in 10" x 2-1/2" and 11" x 2-1/2" with 12" backing plate. Our 10" brake kit weighs only 45 lbs! Less unsprung weight equals a better ride. This is the best street rod brake kit ever!

- 10" Ford Drum Brake Kit **\$525.00**



EC-704, 739ACK

SuperLite 6R Front Brake Kit-6 pistons, 12.88" rotors

SL6R forged billet six-piston caliper disc kits are built exclusively for 17" and larger wheels. A full range of options for caliper finishes and rotor designs are available.

- 140-10737 1955-57 Chevy (may fit some 15") **\$1,488.00**
 140-9801 1971-18 Mustang II (original disc spindles) . **\$2,176.00**
 140-10739 1937-48 Ford Spindle (may fit some 15") . **\$1,300.00**
 140-9803 1967-69 Camaro, 1964-1974 A-Body **\$2,176.00**
 140-10485 1970-78 Camaro / Firebird* ** **\$2,176.00**

*May require modifications to stock spindles. **11" rotor spindles only

1974-78 MUSTANG II/1973-80 PINTO SPINDLES

ECI kit uses stock big piston GM calipers and 11 inch GM or Ford rotors. Available as brackets, bearings and hardware only or complete with rotors and loaded calipers.

- EC-703 GM 4-3/4" Bolt Circle-3/4" OFFSET. .Basic Kit **\$150.00**
 EC-703CK Complete Kit **\$450.00**
 EC-722 GM 4-3/4" Bolt Circle- NO OFFSET. .Basic Kit **\$150.00**
 EC-722CK Complete Kit **\$450.00**
 EC-716 FORD 4-1/2" B.C. -5/16" OFFSET . .Basic Kit **\$180.00**
 EC-716CK Complete Kit **\$450.00**
- ZERO OFFSET with ALUMINUM HUBS (shown)**
- EC-704CK FORD 4-1/2" or GM 4-3/4".... Complete Kit **\$575.00**
 EC-739ACK GM 5" Bolt Circle Complete Kit **\$600.00**
 EC-739BCK FORD 5-1/2" Bolt Circle Complete Kit **\$625.00**

HEIDTS MUSTANG II DISC BRAKE CONVERSIONS

Upgrade your Mustang II spindles to 11" rotors. Use 78 and up GM calipers available as a bracket kit only or as a complete kit including calipers and rotors. Also with Wilwood calipers.



- DF-101-F Basic disc kit, Ford rotors. **\$120.00**
 DF-201-F Ford disc kit complete **\$645.00**
 DF-101-C Basic Kit, Chevy rotors **\$126.00**
 DF-201-C Chevy disc kit complete **\$645.00**
 DF-202 Kit with 4 piston Wilwood calipers* **\$812.00**

*specify bolt circle

Call 402.886.2275 or click: www.heinzmanstreetrods.com

Hot Rod Front Disc Brake Kits

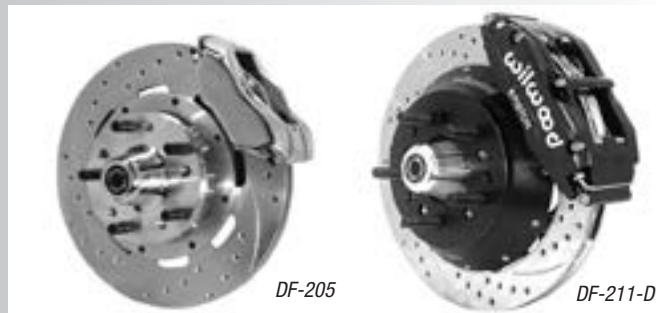

WILWOOD DISCS BRAKES FOR HEIDTS SPINDLES

Big disc brake kits designed for Heidts Mustang II and 55-57 Chevy dropped spindles. Include 4-piston Wilwood calipers with 11 or 12" plain or Zinc cross-drilled/slotted rotors or 13" rotors with 6-piston calipers. Will also work with most Mustang II spindles.

FOR HEIDTS MUSTANG II DROPPED SPINDLES

- DF-202-B 11" Smooth rotors, black calipers \$871.00
- DF-202-P 11" Smooth Rotors, polished calipers \$886.00
- DF-202-R 11" Smooth Rotors, red calipers \$966.00
- DF-202-D-B 11" Drilled rotors, black calipers \$986.00
- DF-202-D-P 11" Drilled Rotors, polished calipers \$1000.00
- DF-202-D-R 11" Drilled Rotors, red calipers \$1087.00
- DF-208-B 12" Drilled rotors, black calipers \$1,060.00
- DF-208-P 12" Drilled Rotors , polished calipers . . . \$1,065.00
- DF-208-R 12" Drilled Rotors, red calipers \$1,147.00
- DF-206-B 13" Drilled Rotors & 6 piston black cal . . \$1,970.00
- DF-206-P 13" Drilled Rotors & 6 piston polished . . \$2,069.00
- DF-206-R 13" Drilled Rotors & 6 piston red cal . . . \$2,133.00

FOR HEIDTS 1955-57 CHEVY DROPPED SPINDLES

- DF-205 11" Drilled Rotors, polished calipers \$1,330.00
- DF-205-D 11" Drilled Rotors, polished hubs/calipers . . \$1,578.00
- DF-210-D 12" Drilled Rotors, polished hubs/calipers . . \$1,620.00
- DF-211-D 13" Drilled Rotors, black hubs/calipers \$2,896.00



ECI REAR DISC BRAKE CONVERSIONS FOR GM, FORD AND CHRYSLER REAR AXLES

The ECI rear disc brake conversion kits adapts Cadillac Seville/Eldorado rear calipers and 11 inch rear rotors to 8, 8.8 and 9" Ford and GM 10 and 12 bolt GM ("C" clip type), 55-64 Chevy and 8-3/4"/Dana 60 type rear axles assemblies. Calipers utilize the OEM integral parking brake mechanism and standard GM pads. These conversions are the easiest way to upgrade to rear disc brakes with a functional OEM style parking brake.

Kits are supplied complete with rebuilt rear caliper assemblies with pads, new 11 inch diameter rotors (11-3/4" on EC-843), caliper brackets and mounting hardware. Axle bearing removal is NOT required for installation.

NOTE: Minor axle flange machining is required for rotor installation on some Ford and GM installations. Chrysler product rear axles require one piece "GREEN" axle bearings.

FORD REAR ENDS

- EC-840 8" and 9" rear axles, small flange
4-1/2" bolt circle \$575.00
- EC-841 8" and 9" rear axles, large flange
4-1/2" bolt circle \$575.00
- EC-841LV Lincoln Versailles retrofit kit \$625.00
- EC-842 8" and 9" rear axles, new style flange,
4-1/2" bolt circle \$575.00
- EC-843 9" rear axles, 5-1/2" bolt circle \$575.00
- EC-847 8.8" rear axles Ford, 5 lug axles only
4-1/2" bolt circle \$575.00

GM REAR ENDS

- EC-844 GM 10 and 12 bolt rear axles w/axle retainers only
4-3/4" bolt circle, (w/o "C" clip) \$575.00
- EC-845 GM 10 and 12 bolt rear axles with "C" clip only
4-3/4" bolt circle, \$575.00
- EC-845A same as above for big car housing ends. . \$575.00
- EC-845B same as above for 5 inch bolt circle \$575.00
- EC-846 1955-64 Chevy rear axles, 4-3/4" bolt circle . . \$575.00
- EC-848 1973-94 Chevy/GMC 1/2 ton pickup with "C" clip
axle retainers only, 5" bolt circle \$575.00

CHRYSLER REAR ENDS

- EC-849 Chrysler 8-3/4" and Dana 60 \$575.00

All Above w/13 in. dia. rotors add \$100.00

Hot Rod Front and Rear Disc Brake Kits





WILWOOD PRO SERIES REAR AXLE KITS

Internal parking brake fits 15" and up wheels

Forged billet Dynapro Low-Profile four-piston calipers, 11.00" one-piece hat and rotor assemblies, and high friction pads. The neatly hidden internal shoe system provides a clean installation with superior static holding power for parking. Black or Red powder coated calipers, solid rotors standard. Optional caliper finishes and rotor designs available.

Kits with black/red calipers w/ parking brake	\$993.00
Add for Drilled & Slotted rotors pr	\$112.00
140-11405 1955-57 Chevy / 56 Corvette, 2.34" offset	\$993.00
140-11827 1959-64 Impala / 57-62 Corvette, 2.91" offset .	\$993.00
140-11397 Olds/Pontiac, 2.81" offset	\$993.00
140-11403 Small Ford, 2.50" offset	\$993.00
140-11387 Big Ford, 2.36" offset	\$993.00
140-11402 Big Ford (New Style), 2.36" offset	\$993.00
140-11396 8.8 Mustang, 2.50" offset	\$993.00
140-11385 Chevy C10, 2.42" offset.	\$993.00
140-11395 Mopar/Dana 60, 2.36" offset	\$993.00
140-11386 Mopar/Dana60 , 2.50" offset	\$993.00
140-9140 9" Ford, 2.50" New Style), offset.	\$993.00
140-9741	\$993.00



BRAKE PEDAL KIT

Designed for use with Mustang cylinder.

AS-3240 Model A (mounts to boxed frame)	\$209.00
AS-3239 1932 Ford (mounts to boxed frame)	\$204.00
AS-2034 1934 Ford (mounts to boxed frame)	\$204.00
AS-2040 1935 to 40 Ford (mounts to stock X)	\$204.00
AS-1026 1937 to 39 Chevy	\$204.00
AS-1041 1940-48 Chevy.	\$110.00



MASTER CYLINDER ADAPTER

This kit bolts a Pinto-Mustang master cylinder to the original 1941-1948 Ford brake pedal assembly. Includes adapter, new shaft, spacers, bolts and instructions. Kit spaces pedal assembly over to clear Turbo 350. Some fitting is required.

AS-2022 Adapter kit	\$89.00
AU2036 Mustang 15/16" bore, standard	\$89.00
AU-2037 Mustang 1" bore, standard.	\$89.00



POWER BRAKE ADAPTER

Adapts Chassis Engineering Power booster or stock Pinto booster assembly to the 1939-1948 Ford pedal. This is a good fit and well worth doing.

AS-2058	\$100.00
-------------------	----------



MASTER CYLINDERS

State usage when ordering.

	7/8" bore single, manual disc/drum	\$79.00
	1" bore single, power disc/drum or disc/disc	\$79.00
AU-2036	Mustang 15/16" bore, standard or power. .	\$79.00
AU-2037	Mustang 1" bore, standard or power	\$79.00
AU-2041	Remote Fill 15/16" bore, power only	\$78.70
AU-2042	Remote Fill 1" bore, power only.	\$92.00
AU-2043	Remote Fill 1-1/8" bore, power only	\$129.00
MC1312A	Corvette 1" bore	\$85.20
260-29000	Wilwood 7/8" bore	\$249.50



POWER BRAKE BOOSTER- DUAL DIAPHRAGM

This 7 inch dual booster is an ideal size for most street rods

AS-2075	7 inch dual booster	\$145.00
8531	8 inch dual booster	\$145.00

Call 402.886.2275 or click: www.heinzmanstreetrods.com

Hot Rod Rear Disc Brake Kits and Components

Hot Rod Brake Components



ECI MASTER CYLINDER/BOOSTER PEDAL ASSEMBLIES

These are brand new 7" boosters assembled with a new Corvette 1 inch bore 4 wheel disc brake master cylinder. They are pressure and vacuum tested before being shipped to you. They can be used on a disc/drum brake combination by installing a GM factory proportioning valve with built in residual pressure valve for the drum brakes. Pedal assemblies mount under the floor and include bracket, pedal and hardware.

- EC-500** 1928-32 Ford (and universal) brake pedal/power booster mounting assembly. This mount welds to a boxed 28-32 type chassis **\$425.00**
- EC-510** 1933/34 Ford, master/booster/pedal mnt. . . **\$425.00**
- EC-520** 1935-40 Ford, master/booster/pedal mnt. . . **\$425.00**
- EC-520A** 1941-48 Ford, master/booster/pedal mnt. . . **\$425.00**
- EC-600** 1955-64 Chevrolet Passenger Car master/booster/ mounting bracket **\$295.00**
- EC-605** 1955-64 Chevy w/9" power booster **\$325.00**
- EC-610** 1962-67 Nova master/booster/mounting bracket **\$295.00**
- EC-615** 1964-66 Chevelle master/booster/mounting bracket **\$325.00**
- EC-505** 1947-54 Chevy pick-up **\$395.00**
- EC-515** 1955-59 Chevy pick-up. **\$395.00**
- EC-524** 1948-52 Ford 1/2 ton Pickup **\$425.00**
- EC-522** 1953-56 Ford 1/2 ton Pickup **\$425.00**
with standard shift, add **\$50.00**



EC-515 shown



EC-420 shown

ECI MASTER CYLINDER ADAPTER

A neat, no hassle way to update to a modern dual master cylinder. Bolts either a Mustang or Corvette master cylinder to the stock brake pedal in the stock master cylinder location. Supplied with push rod, rod end, hardware and new boot. Master cylinder not included.

- EC-410** 1939-40 Ford car **\$49.95**
- EC-415** 1941-48 Ford car **\$99.95**
- EC-450** 1949-51 Ford car **\$219.95**
- EC-410A** 1948-52 Ford pickup. **\$49.95**
- EC-420** 1953-56 Ford pickup. **\$84.95**
- EC-412** 1957-62 Ford pickup. **\$84.95**
- EC-430** 1937-39 Chevy car **\$129.95**
- EC-440** 1940-54 Chevy car (automatic only) **\$129.95**
- EC-440S** 1940-54 Chevy car (standard shift) **\$159.95**
- EC-850** 1953-62 Corvette. **\$250.00**
- EC-420** 1947-54 Chevy pickup **\$89.95**
- EC-425** 1955-59 Chevy pickup **\$110.00**



ECI POWER BRAKE BOOSTER/MASTER CYLINDER

This power brake booster/master cylinder is engineered and designed specifically for street rod applications. Small 7" diameter booster fits under the floor for out of the way installation. The ECI street rod booster is equipped with the right components to provide the right performance and sensitivity for street rod use. It provides power brake performance with dual master cylinder safety. These are brand new boosters assembled with a new Corvette 1" bore 4 wheel disc brake master cylinder. They are pressure and vacuum tested before being shipped to you. They can be used on a disc/drum brake combination by installing our GM factory proportioning valve with built in residual pressure valve for the drum brakes.

- EC-490** 7" dia. booster/master cylinder **\$225.00**
- EC-590** 8" dia. booster/master cylinder **\$225.00**
- EC-495** Remote fill master cylinder kits with fittings, lines, plastic reservoir, bracket for above . . . **\$189.95**



HIGH-POWER ELECTRIC BOOSTER AND MASTER CYLINDER ASSEMBLY

This high pressure system uses an electric remote booster that can be mounted anywhere in the car. This cleans up the firewall, frees up extra valve cover clearance and solves the low vacuum problem that many high performance engines have. Good looking, light weight and easy to install. Features a 1-3/16" bore, dual circuits and built in metering/proportioning valve. Only 8" x 3.6" x 3.3". The electric unit is only 8" x 6" x 6". System also has a hydraulic accumulator that stores pressure and provides 10-15 boosted stops if the electrical system fails. After that, you have normal manual brakes.

- 10-56** Electric power brake booster/M.C. **\$1,400.00**



REMOTE FILL TANK

Milled aluminum tank for remote filling of master cylinder. Includes adapters for cylinder. All fittings are 1/8" pipe. Can be connected with hose or braided line. A quality piece. Use with remote fill master cylinder.

- AS-2060** Remote fill tank. **\$221.00**



PROPORTIONING VALVE

For disc/drum or 4 wheel disc brake systems.

Wilwood Adjustable \$49.95



RESIDUAL PRESSURE CHECK VALVE

10 pound valve: drum brakes. \$22.00

2 pound valve: disc brakes. \$22.00



BULKHEAD FITTINGS

Takes the brake line thru the frame rail instead of around it. Stainless Steel with 1/8" pipe fittings on both ends.

AU-0071 Bulkhead Fittings- for 2" thick frame rail . . \$45.00



BRAKE HOSE KITS

Show quality braided stainless steel brake hoses. Specify type of calipers: GM, Wilwood, Mustang

Brake Hose Kits \$65.00



BRAKE LINE FITTINGS

Thru frame brake line fittings are available in stainless steel to complete your brake line hook-up. Short fittings are for frame thickness 1-1/8 to 2". Long Fittings are for frame thickness 1-1/2 to 2-3/8". Fittings have 1/8" NPT female thread on inside frame end and -3AN male fitting on outside. Weld-in fittings are plain steel with 1/8" NPT female threads on both ends, 2-1/4" long. Bulkhead fittings also available for single thickness frames with -3AN male fittings on both ends. Other adapter fittings available.

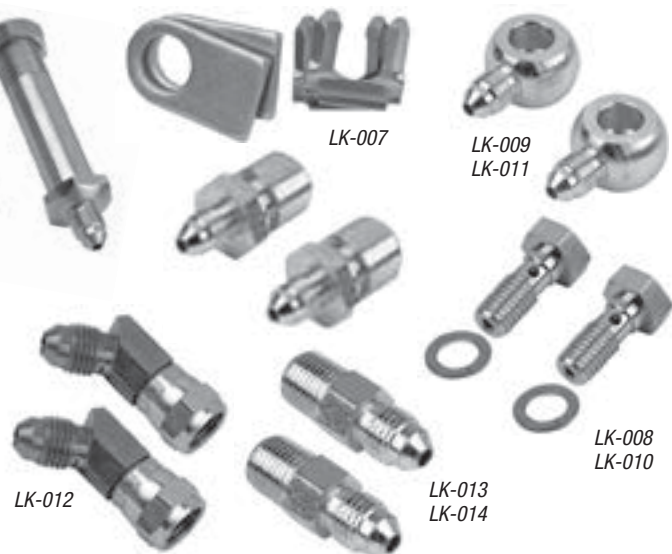

- LF-004 90 Degree Fitting, -3AN to 1/8" NPT \$13.95**
- LF-011 Weld-on Tab each \$1.95**
- LF-012 Fitting, -3 An To 3/16 Inverted Flair each \$6.90**
- LF-013 Tab Fitting Clip each \$1.00**
- LF-014 Banjo Fitting, 10 mm to -3" each \$13.00**
- LF-015-A 10 mm Banjo Fitting Bolt. each \$4.25**
- LF-015-W 10 mm Banjo Fitting Washer. Each \$0.89**
- LF-018-1 Thru Frame Fitting Weld-In Kit 1/8" NPT to 1/8" NPT (2-1/8" Long) \$12.50**
- LF-018-2 Thru Frame Fitting Weld-In Kit 1/8" NPT to 1/8" NPT (2-1/4" Long) \$12.50**
- LF-018-3 Thru Frame Fitting Weld-In Kit 1/8" NPT to 1/8" NPT (2-1/2" Long) \$12.50**
- LF-018-4 Thru Frame Fitting Weld-In Kit 1/8" NPT to 1/8" NPT (3-1/4" Long) \$12.50**
- LF-020 Inverted Flare T-Fittings (3/16") \$8.20**

- LK-001 Thru Frame Kit, short -3 AN to 1/8" NPT \$45.95**
- LK-002 Thru Frame Kit, long -3 AN to 1/8" NPT \$45.95**
- LK-003 Thru Frame Kit, short 1/8" NPT to 1/8" NPT . \$45.95**
- LK-004 Thru Frame Kit, long 1/8" NPT to 1/8" NPT . . \$45.95**
- LK-005 Thru Frame Bulkhead Kit -3 AN to -3AN" . . . \$55.95**
- LK-007 Weld-On Tab Fitting Kit, -3AN To 3/16 Inverted Flair Fittings With Tabs & Clips \$16.50**
- LK-008 Banjo Bolt Kit - Bolts & Washers (10 mm) . . . \$11.65**
- LK-009 Banjo Fittings -10 mm to -3AN \$15.95**
- LK-010 Banjo Bolt Kit -7/16-20 to -3AN \$10.95**
- LK-011 Banjo Fittings -7/16 to -3AN \$17.95**
- LK-012 Adapters -4 Male to 45 Swivel \$21.65**
- LK-013 Adapters -3AN to 1/8" NPT Male \$10.95**
- LK-014 Adapters -4AN to 1/8" NPT Male \$10.95**

Call 402.886.2275 or click: www.heinzmanstreetrods.com

Hot Rod Brake Components

WESCOTT FIBERGLASS BODIES

Westcott bodies feature hand laminated fiberglass with an internal steel support structure. Westcott does not use wood glued to the inside of the body that can show through. Bodies are made up of panels that mimic the stock steel panels to eliminate stress and expansion-contraction issues. The bodies are designed to fit original or reproduction Ford frames. The doors and deck lid are fitted and hinged and come with modern "Bear Jaw" style latches. Complete top iron kits are available for roadster and convertible bodies.

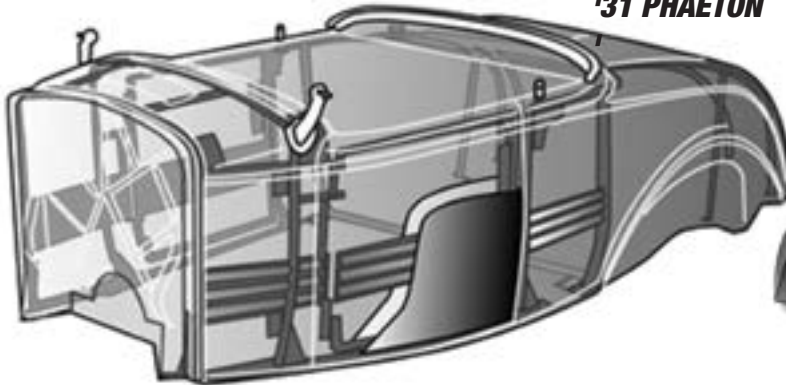

'26 "T" ROADSTER

'29 ROADSTER

'29 ROADSTER PICKUP

'29 PHAETON

'31 ROADSTER

'31 ROADSTER PICKUP

'31 PHAETON

'31 5-WINDOW COUPE

'32 ROADSTER

'32 HIBOY SPECIAL

'32 PHAETON

'32 3-WINDOW COUPE

'34 ROADSTER

'39 CONVERTIBLE

'40 CONVERTIBLE



1932 THREE-WINDOW COUPE BODY

Available with a stock height or chopped 2.5" in front and 2" rear filled top.

Please specify options when ordering.

A. Firewall: "stock" modified stock or recessed "flat" style

D. Dash: "stock," "filled," or with or without glove box

E. Cowl: working vent or filled cowl

F. Door: stock (outside) or hidden hinges

G. Deck latch: stock or remote style

1932 Roadster replica body..... \$19,500.00

Working cowl vent..... extra \$300.00

Working glove box..... extra \$300.00

1932 Fender Package \$1,900.00

includes: 1 pr front fenders • 1 pr rear fenders • 1 grille shell (Specify filled or stock grille shell) 1 front apron (specify standard or chop) 1 pair rear frame horn covers

Many more options please call

1932 ROADSTER BODY

Street rod style. Includes the lower windshield posts and top mounts for the traditional style windshield frame, and posts and top brackets for the folding top irons.

Please specify options when ordering.

A. Firewall: "stock" style or recessed "flat" style

B. Seat: stock or 2" extra seat setback

C. Deck lid: rumble or trunk lid

D. Dash: "stock," "flat," or "auburn" style

E. Cowl: working vent or filled cowl

F. Door: stock (outside or hidden hinges)

G. Deck latch: stock or remote style

1932 Roadster replica body..... \$10,000.00

Working cowl vent..... extra \$300.00

1932 Fender Package \$1,900.00

includes: 1 pair front fenders • 1 pair rear fenders • 1 grille shell (specify filled or stock grille shell) 1 front apron (specify standard or chop) 1 pair rear frame horn covers





1933-34 ROADSTER BODY

Please specify options when ordering.

- A. Firewall: "stock", Chevy V8, Ford V8, or big block
- C. Deck lid: rumble or trunk lid
- D. Dash: 1933 or 1934 body, dash with glove box lid or filled
- E. Cowl: working vent or filled cowl
- F. Door: stock outside or hidden hinges

1934 Roadster replica body	\$12,000.00
Working cowl vent	extra \$300.00
Opening glove box lid	extra \$300.00
Front fenders, 1933 or 1934 style	\$580.00
Inner fenders, 1933 or 1934 style	\$195.00
Rear fenders	\$450.00
Gas tank cover, stock or smooth	\$250.00
Fiberglass package total	\$2,000.00



1939 AND 1940 CONVERTIBLE BODY

Please specify body type.

- 1939 Deluxe convertible with rumble lid**
- 1939 Super deluxe convertible with trunk**
- 1940 Deluxe convertible with space for back seat**

Please specify options when ordering.

- A. Firewall: "stock," Chevy V8, Ford V8, or big block V8
- B. Dash: 1939 filled or 1940 filled style (both styles have opening glove box lids)
- C. Cowl: working vent or filled cowl
- D. Chop: stock height windshield or 2" chop

1939-40 Convertible replica body only	\$17,500.00
Working cowl vent	extra \$200.00
Fenders, inner fenders and hood (fiberglass) kit	\$3,500.00
Power window kit (installed)	\$1,140.00
2" chop top iron kit for 1939 (installed)	\$2,950.00
2" chop top iron kit for 1940 (installed)	\$3,950.00

Pacific Industries Steel Bodies and Parts



STEEL 32 5-WINDOW COUPE BODY

Each panel is reproduced exactly as the original and can be used to repair an original Ford body. Bodies include hung doors and decklid and includes all hardwood inner structure. Door latches and interior garnish moldings are included. Firewall and dash sold separately.

Options include original or solid roof and with or w/o cowl vent.

B20000-A	1932 Steel 5W replica body	\$28,000.00
B20089	Original firewall w/o holes	\$750.00
B20019	Complete original floor pan	\$2,380.00
B20035	Original Trunk Lid	\$695.00
B20033-34	Right and left quarter panels	\$1,200.00
B20015-16	Right and left door shells	\$1,949.00



B20000-A

ALMOST EVERY SHEETMETAL PART FOR 5 WINDOWS IS AVAILABLE INCLUDING ROOF SKINS
1932 PICK-UP CAB COMING SOON



B20033

Call 402.886.2275 or click: www.heinzmanstreetrods.com

Westcott Fiberglass Bodies and Fenders

WESCOTT FIBERGLASS FENDERS AND BODY PARTS



1928-40 FORD FRONT FENDERS-FIBERGLASS

1928-29	each	\$450.00
1930-31	each	\$450.00
1932	each	\$450.00
1933-34	each	\$450.00
1935	each	\$625.00
1936	each	\$625.00
1937	each	\$625.00
1938 Standard	each	\$625.00
1938 Deluxe/ 39 Standard	each	\$625.00
1939 Deluxe/ 40 Standard and Deluxe	each	\$625.00

1928-40 FORD REAR FENDERS-FIBERGLASS

1928-29	each	\$325.00
1930-31	each	\$325.00
1932 Coupe/Roadster	each	\$325.00
1932 Sedan	each	\$325.00
1933-34 Coupe/Roadster	each	\$325.00
1933-34 Sedan	each	\$325.00
1935 Coupe/Roadster	each	\$475.00
1935 Sedan	each	\$475.00
1936 Coupe/Roadster	each	\$475.00
1936 Sedan	each	\$475.00
1937 Coupe/Convert	each	\$475.00
1937 Slant Back Sedan	each	\$475.00
1937 Hump Back Sedan	each	\$475.00
1938 Coupe/Convert	each	\$475.00
1938 Standard Sedan	each	\$475.00
1938 Deluxe/39 Sedan/Coupe Sedan	each	\$475.00
1940 Coupe Sedan	each	\$475.00
1935-37 Pick-up	each	\$475.00
1938-41 Pick-up	each	\$525.00

1932 GRILLE SHELLS-STEEL

Steel 1932 grille shells fit original, Walker, and many other reproduction radiators. They have the proper flanges for the grille insert, rear stainless trim, and original type hood lacing. Available stock or "filled".



B8200HRS	Stock Style steel	each	\$275.00
B82000R	Filled Style steel	each	\$275.00



FIBERGLASS RUNNING BOARDS

1933-40	Smoothie fiberglass	each	\$375.00
1935-'37	Pick-up running board	each	\$375.00
1938-'39	Pick-up running board	each	\$375.00
1940-'41	Pickup running board	each	\$375.00

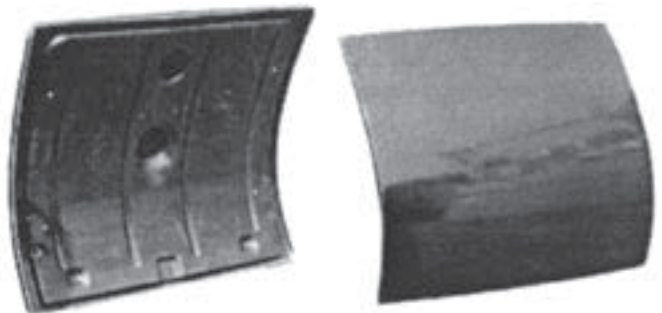

DECK LIDS

1928-29 Roadster and Coupe	\$850.00
1930-31 Roadster and Coupe	\$850.00
1932 Roadster and 5-Window Coupe	\$850.00
1932 3-Window Coupe	\$850.00
1933-34 Roadster & Coupe trunk or using remote rumble latch	\$850.00
1933-34 Roadster using outside handle rumble latch	\$850.00
1935-36 3 or 5-Window Coupe	\$850.00
1935-38 Convertible w/rumble	\$850.00
1935-37 Roadster	\$850.00
1937-38 Coupe and Club conv. w/trunk	\$850.00
1939 Convertible w/rumble	\$850.00
1939-40 Coupe trunk lid	\$1,300.00
1940 Convertible trunk lid	\$1,300.00



1933-34 FIBERGLASS GAS TANK COVERS

Stock passenger models with bumper boss	\$200.00
Smooth, passenger models	\$200.00
Sedan delivery, stock	\$200.00
Hiboy, recessed licence, tapered, use without fenders	..	\$250.00

Fiberglass Fenders and Body Parts



BOB DRAKE STEEL RUNNING BOARDS

1932-1948 FORD CAR With original style rubber covers

B-16450/1	1932 Cars and Pickup	pair	\$815.00
40-16450/1	1933-34 Cars	pair	\$1,495.00
48-16450/1	1935-36 Cars	pair	\$1,495.00
78-16450/1-BD	1937-38 Cars, 1939 Standard	pair	\$1,495.00
91-16450/1-BD	1939 Deluxe, 1940 Standard	pair	\$1,495.00



DOOR BOTTOM PATCH PANELS

1932-1936 FORD CARS AND PICKUPS

B-336	1932 5-W Coupe and 4-door	pair	\$125.00
B-436	1932 Tudor Sedan and Victoria	pair	\$125.00
FR-100	1932 3-W Coupe	pair	\$130.00
B-136	1932 Roadster	pair	\$100.00
B-836	1932-34 Pick-up	pair	\$70.00
FR-101	1933-34 5-W and 4-door	pair	\$130.00
FR-102	1933-34 2-door or 3-W Coupe	pair	\$130.00
FR-103	1933-34 5-W coupe and 4-door Inner	pair	\$95.00
FR-104	1933-34 3-W, 2-door, Victoria Inner	pair	\$75.00
FR-107	1933-34 Cabriolet	pair	\$130.00
FR-108	1933-34 Cabriolet, Inner	pair	\$95.00
68-336	1935-36 5-Window	pair	\$220.00
68-236	1935-36 3-Window	pair	\$220.00



REAR BODY PANELS BELOW TRUNK LID

1932-1937 FORD CAR

B-163	1932 Roadster or Coupe	each	\$195.00
B-263	1932 3-W	each	\$279.00
40-163	1933-34 Coupe, Roadster, Cabriolet	each	\$279.00
78-363	1937-38 Coupe	each	\$300.00
78-463	1937 Sedan-Slant Back	each	\$300.00
01A-950	1939 Deluxe, 1940 Coupe & Convertible	each	\$400.00
01A-463	1940 Sedan	each	\$300.00

RUBBER RUNNING BOARD COVERS

1932-1948 FORD CAR

Form fitting molded covers, from Vintique, "the finest available" includes glue & instructions.

18-16450/1	1932 Passenger	pair	\$295.00
40-16450/1	1933-34 Passenger	pair	\$295.00
48-16450/1	1935-36 Passenger	pair	\$295.00
78-16450/1	1937-38 Passenger, '39 Standard	pair	\$295.00
91A-16450/1	1939 Deluxe, '40 Std. & Deluxe Pass	pair	\$295.00
21A-16450/1	1942-48 Passenger	pair	\$295.00



INNER REAR WHEEL WELL

Die-stamped inner rear fender panel patches. Fits roadster, 5-window coupe & cabriolet. May also be used on 2 door Vicky with slight alteration.

B-181	1932	pair	\$150.00
40-181	1933-34	pair	\$220.00



COWL PATCH PANELS

1932-1936 FORD CAR

B-114	1932	pair	\$125.00
40-114	1933-34	pair	\$125.00
48-114	1935-36	pair	\$125.00



QUARTER PATCH PANEL

1932-1940 FORD CAR

B-150	1932 all bodies	pair	\$100.00
40-350	1933-34 all bodies	pair	\$100.00
48-350	1935-36 all bodies	pair	\$100.00
78-350	1937-40 all bodies	pair	\$230.00

REAR FRAME HORN COVERS

Die-stamped steel.

B-16399	1932 Rear frame horn covers	pair	\$225.00
---------	-----------------------------	------	----------





ROCKER PANELS

1932-1940 FORD CAR specify body type

B-7010110/1	1932.....	each	\$125.00
40-7010110/1	1933-34.....	each	\$125.00
48-7010110/1	1935-36.....	each	\$220.00
78-7010110/1	1937-40.....	each	\$125.00

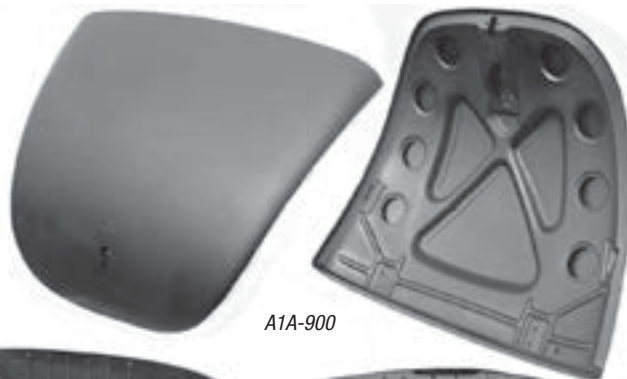

A1A-900



A1A-201



A1A-200-A

FENDER BRACES

B-16025	1932 Front	each	\$40.00
40-16025	1933-34 Front	pair	\$90.00
40-16094	1933-34 Rear Front, L or R	each	\$30.00
48-16094	1935-36 Rear Front, L or R	each	\$30.00
78-16094	1937-39 Rear Front, L or R, Standard	each	\$30.00
91A-16088/9	1939 Deluxe, 40 All Front, L or R.....	pair	\$50.00
48-16180	1935-'36 Rear, L or R	each	\$30.00
78-16180	1935-'36 Rear, L or R	each	\$30.00

DENNIS CARPENTER & BOB DRAKE 1939-40 FORD SHEET METAL

A1A-900	1939-40 Coupe trunk lid	\$1,250.00
A1A-200-A	1939-40 Original firewall	\$600.00
A1A-201	1937-40 Recessed hot rod firewall	\$600.00
01A-558-K	1937-40 Car trans cover and Toe board	\$250.00
91A-400/1	1939 Deluxe, 1940 cowl side panels	pair \$675.00
01A-950	1939 Coupe, 1940 Coupe and Convertible lower deck panel	\$450.00
01A-750-SK	1940 Coupe roof skin	\$1,200.00
01A-751/2	1939-40 Coupe rain gutter	pair \$500.00
01A-800/1	1939-40 Coupe rear quarter panels	pair \$1,500.00
01A-16082/3	1939 Deluxe, 1940 Car, 1940-41 Pickup front fender inner apron panels	pair \$220.00
01A-600	1940 Coupe complete door RH	\$1,150.00
01A-601	1940 Coupe complete door LH	\$1,150.00
01A-604	1940 Coupe door skin RH	\$800.00
01A-605	1940 Coupe door skin LH	\$800.00
01A-16005	1939 Deluxe, 1940 Car, front fender RH	\$850.00
01A-16006	1939 Deluxe, 1940 Car, front fender LH	\$850.00
01A-16312	1940 Car, rear fender RH	\$750.00
01A-16313	1940 Car, rear fender LH	\$750.00
01A-16088/9	1939 Deluxe, 1940 Standard & Deluxe 1940-41 Pickup front fender brace panels	pair \$75.00
01A-303	1940 car dash panel	\$485.00



01A-16082/3



91A-400/1



01A-800/1

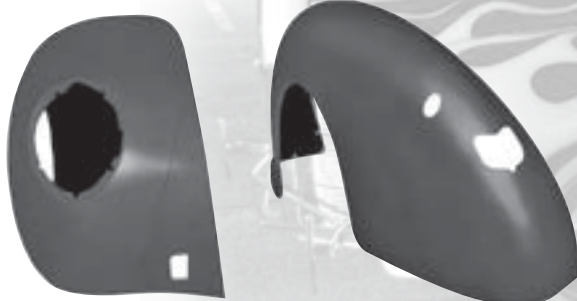

01A-16005

01A-16312

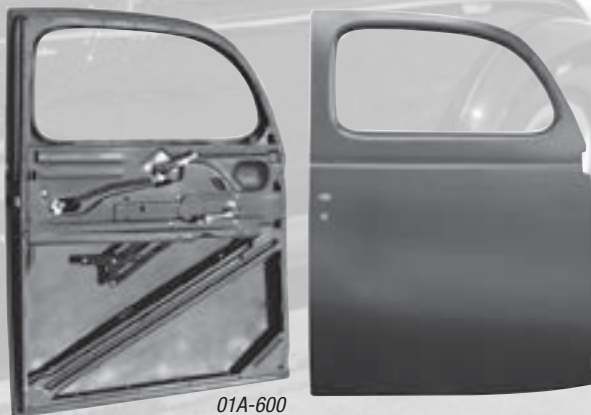

01A-600

Steel Replacement Body Panels

BITCHIN' PRODUCTS FIREWALLS AND FLOORS



1932 Ford Car



1933-34 Ford Car



1937-40 Ford Car

FIREWALLS FOR 1928-48 FORD CARS & PICKUPS

FORD CARS	small block	big block
1928-29	281000 \$390.00	
1930-'31	301005 \$395.00	301000 \$395.00
1932	321040 \$420.00	321042 \$395.00
1933-34	331051 \$420.00	331008 \$430.00
1935-36	351071 \$420.00	351010 \$430.00
1937-40	371030 \$420.00	371012 \$430.00
1941-48	421000 \$395.00	421002 \$395.00

FORD PICKUPS		
1932	321040 \$375.00	321042 \$375.00
1933-34	331000 \$380.00	no set back- flat
1935-36	351000 \$380.00	3" set back
1937	371000 \$380.00	3" set back
1940-47	401000 \$342.00	2" set back

CHEVY CARS		
1937-39	737105 \$320.00	737107 \$320.00
1940	740104 \$300.00	740106 \$300.00
1941-48	742108 \$320.00	742110 \$320.00
1949-52	749100 \$390.00	small or big block- 4.5" set back
1953-54	753100 \$390.00	small or big block- 4.5" set back

CHEVY PICKUPS		
1947-54	751000 \$370.00	small or big block- 3" set back
1955-59	752100 \$440.00	small or big block- 4" set back

TECHNICAL INFORMATION

The set back information provided is for reference only. The descriptions are intended to help you to determine which firewall kit will best fit your application. Be sure to check all measurements before ordering your kit. There are many factors which will affect your choice, engine setback, radiator core thickness, air conditioning or super chargers. If you have any questions, please call.

33-40 Small Block

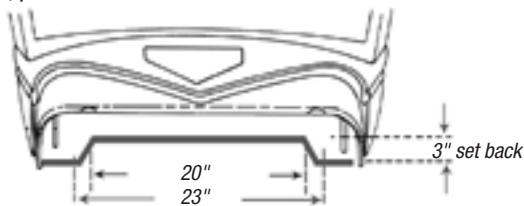

33-40 Big Block

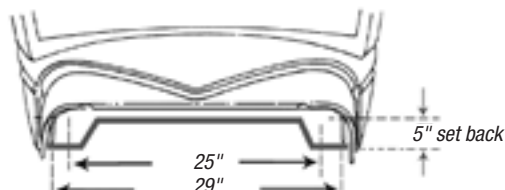

1933-34 Ford Car

BITCHIN' PRODUCTS FLOORBOARD KITS

To complete the restoration of your 1928 to 1948 Ford you will want to install one of these kits which will certainly cure those rusted out floor pan blues. All parts are made to fit with minimum trimming and will give a solid base to mount your seats. There is adequate clearance for the GM Turbo 350/400 series transmissions and kits include all sheet metal parts, hardware, instructions and body sealer needed to complete installation in a professional manner.

FORD FRONT FLOOR KITS

281005	1928-'31 Front floor	\$155.00
281006	1928-'31 Complete floor kit	\$270.00
321041	1932 Front Floor specify small or big block.	\$282.00
331053	1933-34 Front floor small, big block	\$350.00
351014	1935-36 Front floor small, big block	\$350.00
351073	1937-40 Front floor small, big block	\$350.00
421001	1941-48 Front floor small, big block	\$285.00

CHEVY FRONT FLOOR KITS

737126	1937-39 Front floor small, big block	\$288.00
740110	1940 Front floor small, big block.	\$282.00
742112	1941-48 Front floor small, big block	\$280.00
749108	1949-52 Front floor to front seat riser	\$312.00
749120	1949-52 Front floor to under front seat	\$468.00
753105	1953-54 Front floor to front seat riser	\$300.00
753110	1953-54 Front floor to rear seat riser	\$468.00

Call 402.886.2275 or click: www.heinzmanstreetrods.com

Steel Firewall and Floor Repair Panels

BITCHIN' PRODUCTS FLOORS AND ACCESSORIES

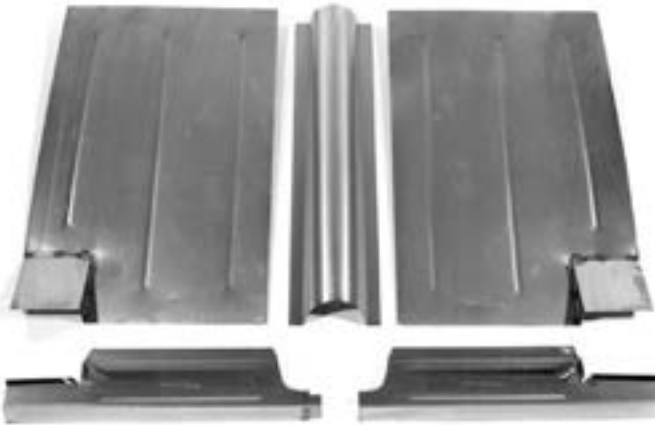

1933-34 Ford Car

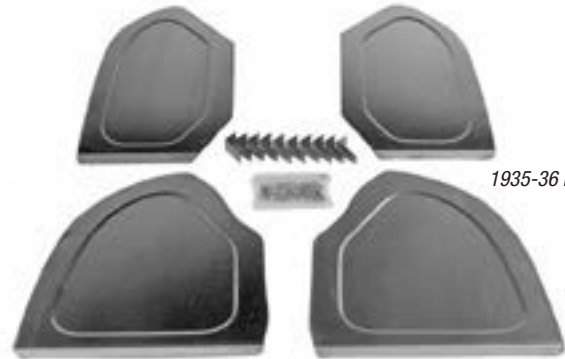

1935-36 Ford Car

BITCHIN' PRODUCTS REAR FLOORBOARD KITS

FORD REAR FLOOR KITS

281006	1928-31 Complete floor kit	\$270.00
321080	1932 3-W Rear floor kit.....	\$342.00
321085	1932 SW, Roadster rear floor kit	\$342.00
321088	1932 2-Door Sedan rear floor kit	\$342.00
321090	1932 4-Door Sedan rear floor kit	\$342.00
321112	1932 Cabriolet rear floor kit	\$342.00
331064	1933-34 Rear floor kit	\$415.00
331064	1934 Victoria rear floor kit	\$135.00
351049	1935-36 Sedan rear floor kit	\$258.00
351050	1935-36 Coupes, Cab. rear floor kit.....	\$294.00
351085	1935-36 Sedan trunk floor kit	\$270.00
351090	1935-36 Coupes, Cab. trunk floor kit.....	\$270.00
371006	1937-40 Rear floor kit	\$250.00
371062	1937-38 Cabriolet trunk floor kit	\$325.00
371055	1939 Convertible trunk floor kit	\$385.00
371050	1937-38 Standard Coupe and Sedan trunk floor kit	\$384.00
371060	1939-40 Standard and Deluxe trunk floor kit	\$545.00
371065	1939-40 Coupe & Deluxe trunk floor kit ..	\$545.00
421034	1941-48 Rear floor kit	\$330.00
421090	1941-48 Rear seat riser kit	\$325.00
421084	1941-48 Trunk floor kit	\$325.00

CHEVY REAR FLOOR KITS

	1937-39 Sedan & Coupe rear floor kit	\$Call
	1937-39 Sedan & Coupe trunk floor kit ...	\$Call
742112	1941-48 Sedan, Coupe & Convertible rear floor kit	\$Call
742112	1941-48 Sedan, Coupe & Convertible trunk floor kit	\$Call
742112	1941-48 Sedan & Coupe trunk floor kit ...	\$Call
749108	1949-52 Front floor to front seat riser.....	\$312.00
749120	1949-52 Front floor to under front seat.....	\$468.00
753105	1953-54 Front floor to front seat riser.....	\$300.00
753110	1953-54 Front floor to rear seat riser	\$468.00

BITCHIN' PRODUCTS STONE GUARD KITS

Kits complete with all parts, hardware and instructions ready to install. In addition to serving as fender braces, Bitchin' Products Stone Guards will prevent stone dents that often occur in the back section of the fenders.

351043	1935-36 Ford passenger car	\$239.00
351022	1937-38 Ford passenger car	\$239.00
391010	1939 Ford Standard passenger car	\$239.00
391003	1939 Ford Deluxe & 1940 pass. car	\$239.00



BATTERY BOX AND MOUNTS

Designed for Group 71 or Group 42 batteries with either top or side mount cables. Provides a safe, positive battery hold down, adequate ventilation and cable protection. The universal brackets can be flush floor mounted, side mounted or mounted half way thru the floor.

901006	Bitchin' Group 71 battery box kit.....	\$110.50
901020	Bitchin' Group 42 battery box kit.....	\$110.50
801020	Optima Battery Box, Billet Specialties.....	\$89.95
	Detroit Speed Optima battery mount.....	\$139.95



BITCHIN' "DESIGNER DASHES"

Available for '37 to '48 Fords and '37 to '48 Chevys. Replace your original dash with a clean, simple design that you can personalize into your own unique dashboard.

371032	1937-39 Ford	\$350.50
401015	1940 Ford	\$350.50
421078	1941- 48 Ford	\$350.50
737195	1937-39 Chevy.....	\$350.50
740118	1940 Chevy	\$350.50
742120	1941-48 Chevy.....	\$350.50

**ROOTLIEB REPRODUCTION
STEEL HOODS**



STEEL HOODS BY ROOTLIEB

Four piece hood kits tops include center hinge strip, side panels include hood handles, latch clips, and hinge rods. Three piece hood kits do not include any hardware. Hood tops are available smooth or louvered, Sides are available stock, smooth, with one or two scoops or with three or four row hot rod louver pattern. Please call.

FORD PASSENGER CAR HOODS Complete stock style four piece hood with original louvers. One piece top, many other options available

- 1928-29, '32 style center strip kit
- 1930-31, '32 style center strip kit
- 1932.....kit
- 1933-34kit
- 1935 stock side louvers not available.....kit
- 1936 sides only, plain or louvered.....kit

CHEVY PASSENGER CAR HOODS

- 1932 with stock side doors.....kit
- 1933 three piece, plain or louvered sides.....kit
- 1934-35 three piece, plain or louvered sides.....kit
- 1936 three or four piece, call.....kit
- 1937-38 sides only, plain or louvered.....kit

1932-36 MOPAR HOODS AVAILABLE TOO! PLEASE CALL.

PLEASE CALL FOR PRICES ON ALL HOODS.



WESTCOTT HOODS.

1940 FORD

One piece fiberglass with internal steel cage. Hood latch and hinges mount to steel structure.

HD39DP 1939 Deluxe & 1940 Standard Pass.. each \$1,175.00

WESTCOTT 1937 FORD HOOD

Beautiful die-stamped steel. Better than the original

- 78-100 Original \$ CALL FOR PRICE
- 78-101 Smooth \$ CALL FOR PRICE



Steel and Fiberglass Ford Hoods

1928-1956 Pickup Truck Parts



1948-52 Ford pickup

1928-56 FORD REAR FENDERS-FIBERGLASS

- 1928-29 Specify L or R each \$275.00
- 1930-31 For "narrow" 41-1/2" wide bed, L or R . . ea \$275.00
- 1930-31 For "wide" 46" wide bed, L or R each \$275.00
- 1932 Pickup, Panel station wagon, L or R . . . each \$275.00
- 1933-34 Pickup, Panel, L or R each \$275.00
- 1935-37 Pick-up, L or R each \$475.00
- 1938-41 Pick-up, L or R each \$500.00
- 1942-47 Pick-up, L or R each \$500.00
- 1948-50 Pick-up, L or R each \$500.00
- 1951-52 Pick-up, L or R each \$500.00
- 1953-56 Pick-up, Stamped steel, L or R each \$400.00



1948-50 Ford pickup

WESCOTT 1928-56 FORD PICKUP FRONT FENDERS -FIBERGLASS

- 1928-29 specify early or late style, L or R each \$390.00
- 1930-31 specify 30 or 31 style, L or R each \$390.00
- 1932 Front fender, specify L or R each \$390.00
- 1933-34 Front fender, specify L or R each \$390.00
- 1935-37 Front fender, specify L or R each \$500.00
- 1938-39 Front fender, specify L or R each \$500.00
- 1938-39 Lower grille extension, specify L or R . . . each \$500.00
- 1940-41 Front fender, specify L or R each \$500.00
- 1942-47 N/A
- 1948-50 Front fender, specify L or R each \$525.00
- 1948-50 Front fender extension, specify L or R . . each \$250.00
- 1951-52 Front fender, specify L or R each \$525.00
- 1951-52 Front fender extension, specify L or R . . each \$175.00
- 1953-56 Steel, specify L or R each \$475.00



1940-41 Ford pickup

1928-56 FORD PICKUP INNER FRONT FENDERS

- 1935-36 Inner front fender, fiberglass each \$130.00
- 1937 Inner front fender, fiberglass each \$130.00
- 1938-39 Inner front fenders, fiberglass each \$175.00
- 1940-41 Inner front fenders, pair \$325.00
- 1940-41 Inner front fenders, Bitchin Steel pair \$350.00
- 1940-41 Inner front fenders, fiberglass each \$225.00
- 1953-56 Inner front fenders, Steel each \$375.00





1938-39 Ford Pickup
Rear Fender Brace



1940-41 Ford Pickup
Front Fender Brace

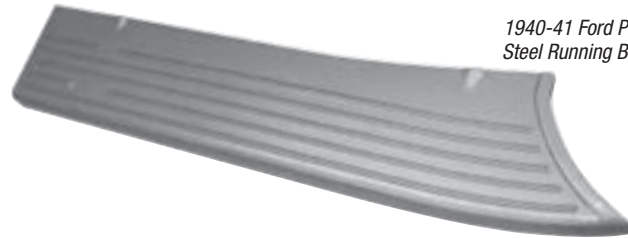

1940-41 Ford Pickup
Steel Running Boards

FENDER BRACES

B-16025	1932 Front, L or R.....each	\$45.00
40-16025	1933-34 Front,pair	\$125.00
40-16094	1933-34 Rear front, L or R.....each	\$30.00
50-16094	1935-37 Front fender skirt brace.....each	\$30.00
50-16391	1935-37 Rear fender, L or R.....each	\$30.50
81C-16094	1938-39 Front, L or R.....each	\$30.00
81C-16391	1938-41 Rear L or R.....each	\$30.00
91A-16088/9	1940-41 Front, L or R,pair	\$30.00
BAAA-16010	1953-56 Front fender, L or R.....each	\$30.00
BAAA-16148	1953-56 Front fender to cowl, L or R...each	\$30.00
BAAA-16340A	1953-56 Rear fender bracket, L or R...each	\$30.00



1933-34 Ford pickup
Splash Apron

1928-56 FORD PICKUP SPLASH APRONS

FSA2829A	1928-28 Stock style, fiberglass.....each	\$120.00
FSA3031A	1930-31 Stock style, fiberglass.....each	\$120.00
A-16527-B	1930-31 Stock style, steel.....each	\$67.50
FSA32A	1932 Stock style, fiberglass.....each	\$120.00
B-16527	1932 Stock style, steel.....each	\$40.00
FSA3334PU	1933-34 Stock style, fiberglass.....each	\$120.00
GSP35PU	1935 Grille inner apron, fiberglass....each	\$100.00
FSB36PU	1936-37 Grille lower shield, fiberglass..each	\$125.00
7C-8188	1948-50 Under grille panel, steel.....each	\$225.00
B3C-8188-A	1953 Under grille panel, fiberglass....each	\$250.00
B4C-8188-A	1954 Under grille panel, fiberglass.....each	\$250.00
B6C-8188-A	1955-56 Under grille panel, fiberglass..each	\$250.00
BAAA-8311	1953-55 Air deflector, steel, L or R....each	\$120.00
BAAA-8310	1956 Air deflector, steel, L or R.....each	\$80.00



LOWER BED SIDE PANELS

Stamped steel panel fills space between box and running boards in front of rear fenders.

10296-L/R	1935-37 Left or right.....each	\$30.00
10298-L/R	1938-41 Left or right.....each	\$26.00
10300-L/R	1942-47 Left or right.....each	\$26.00

1928-56 FORD PICKUP STEEL RUNNING BOARDS

Quality, all-steel boards with all the original details and construction. Heavy gauge, die-formed steel with underside bracing. Most are available smooth or with the exact ribbed top pattern.

A-16450-A	1928-29 Steel, with rubber cover.....pair	\$225.00
A-16450-APU	1928-29 Steel, commercial style with stamped diamond plate.....pair	\$225.00
A-16450-A	1928-29 Steel, smooth.....pair	\$199.00
5A2829A	1928-29 Running board splash aprons fiberglass, L or R.....each	\$185.00
A-16450-BO	1930 Steel, with rubber cover.....pair	\$225.00
A-16450-CM	1931 Steel, with rubber cover.....pair	\$425.00
A-16450-BPU	1930-31 Steel, commercial style with stamped diamond plate.....pair	\$225.00
A-16450-CSM	1930-31 Steel, smooth.....pair	\$199.00
5A31A	1930 Running board splash aprons stamped steel.....pair	\$345.00
5A31A	1931 Running board splash aprons fiberglass, L or R.....each	\$350.00
B-16450-S	1932 Steel, with rubber cover.....pair	\$895.00
B-16450-SM	1932 Steel, smooth.....pair	\$525.00
46-16450-S	1933-34 Steel, w/stock diamond plate..pair	\$375.00
46-16450-SM	1933-34 Steel, smooth.....pair	\$300.00
50-16450/1	1935-37 RH & LH.....pair	\$895.00
81C-16450/1	1938-39 RH & LH.....pair	\$895.00
01C-16450/1	1940-41 RH & LH.....pair	\$700.00
1C-16450-S	1948-52 steel, w/stock ribs.....pair	\$895.00
1C-16450-SM	1948-52 steel, smooth, no ribs.....pair	\$595.00
BAAA-16450-PR	1953-56 steel, w/stock ribs.....pair	\$595.00



FIBERGLASS RUNNING BOARDS

Heavy fiberglass replicas of original running boards with rubber cover detail molded in.

RB3537PU	1935-37 fiberglass, w/stock ribs, L or R..ea	\$450.00
RB3839PU	1938-39 fiberglass, w/stock ribs, L or R..ea	\$450.00
RB4041PU	1940-41 fiberglass, w/stock ribs, L or R..ea	\$450.00

1928-1956 Pickup Truck Parts

FIREWALLS AND FLOORS- BITCHIN' PRODUCTS & DIRECT SHEET METAL



1948-52 Ford Pickup



1948-52 Ford Pickup
Mid-Floor Section



1947-55 Chevy Pickup

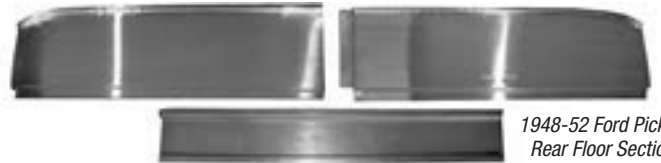

1948-52 Ford Pickup
Rear Floor Section

BITCHIN' PRODUCTS FLOORBOARD KITS

Floorboard kits are made to fit with minimum trimming and will give a solid base to mount your seats. There is adequate clearance for the GM Turbo 350/400 series transmissions and kits include all sheet metal parts, hardware, instructions and body sealer needed to complete installation in a professional manner.

FORD FRONT FLOOR KITS

281005	1928-31 Front floor kit	\$195.00
321003	1932 Front floor specify firewall	\$325.00
351002	1933-39 Front floor	\$350.00
401002	1940-47 Front floor	\$350.00
481000	1948-52 Front floor small, big block	\$350.00
531322	1953-55 Front floor stock replacement, R ea	\$100.00
531323	1953-55 Front floor stock replacement, L ea	\$100.00
531324	1956 Front floor stock replacement, R ea . . .	\$100.00
531225	1956 Front floor stock replacement, L ea . . .	\$100.00

CHEVY FRONT FLOOR KITS

751002	1947-55 Front floor for stock firewall	\$365.00
751003	1947-55 Front floor for bitchin firewall	\$365.00
752115	1955-59 Front floor	\$430.00

BITCHIN' PRODUCTS REAR FLOORBOARD KITS

FORD REAR FLOOR KITS

281056	1928-31 Closed Cab P.U. rear floor	\$270.00
481036	1948-52 Rear floor kit	\$114.00
531225	1953-56 Rear floor stock replacement ea	\$199.00

CHEVY REAR FLOOR KITS

751004	1947-55 Rear floor kit	\$210.00
--------	----------------------------------	----------

BITCHIN' PRODUCTS FIREWALLS

FORD PICKUPS	small block (set back)	big block (set back)
1928-29	281000 (4") . . . \$350.00	
1930-31	301005 (2.5") . \$350.00	301000 (4.5") . . . \$450.00
1932	321040 (2.75") \$430.00	321042 (5") \$450.00
1933-34	331000 \$430.00	t
1935-36	351000 (3") . . . \$430.00	
1937-39	371000 (3") . . . \$430.00	
1940-47	401000 (2") . . . \$350.00	
1948-52	481000 (3") . . . \$375.00	

CHEVY PICKUPS

1947-55	751000 (3") . . . \$425.00	small or big block
1955-59	752100 (4") . . . \$525.00	small or big block

TECHNICAL INFORMATION

The set back information provided is for reference only. The descriptions are intended to help you to determine which firewall kit will best fit your application. Be sure to check all measurements before ordering your kit. There are many factors which will affect your choice, engine setback, radiator core thickness, air conditioning or superchargers. If you have any questions, please call.



1948-52 Ford Pickup Front Floor Section



1955 Chevy Pickup Rear Floor Section

1928-1956 Pickup Truck Parts

1937 Ford Pickup



1934 Ford Pickup
Four Piece Hood

STEEL HOODS BY ROOTLIEB.

Sold as a complete four piece kit with stock style side panels. Two piece hood tops include center hinge strip, side panels include hood handles, latch clips, and hinge rods. Also available with a one piece top. Three piece hood panels do not include any hardware. Hood tops are available smooth or louvered, Sides are available stock, smooth, with one or two scoops or with 3 or 4 row hot rod louver pattern. Please call.

FORD PICKUP HOODS Complete stock style four piece hood with original louvers. One piece top, many other options available

- 1928-29, '32 style center strip kit
- 1930-31, '32 style center strip kit
- 1932-34kit
- 1935-37.....kit

PLEASE CALL FOR PRICES ON ALL HOODS.



WESTCOTT HOODS.

One piece fiberglass with internal steel cage. Hood latch and hinges mount to steel structure.

HD4041PU 1940-41 Ford Pickup fiberglass.....ea \$1175.00



3537FCC



4047FCBM



4852CM

COWL PATCH REPAIR PANELS

1928-56 FORD PICKUP

A-114-A	1928-29	pair	\$100.00
A-114-B	1930-31	pair	\$22.50
B-814	1932-34	pair	\$60.00
3537FCC	1935-37	pair	\$150.00
3839FCC	1938-39	pair	\$165.00
4047FCC	1940-41	pair	\$150.00
4047FCBM	1940-47 Front cab mount	pair	\$75.00
4047HP	1940-47 Lower door hinge post	pair	\$50.00
4852FCC-L	1948-52-Drivers side	each	\$55.00
4852FCC-R	1948-52-Pass. side	each	\$55.00
4852DHP	1948-52 Lower door hinge post	pair	\$50.00
4852FCM	1948-52 Cowl Inner-front cab mounts	pair	\$45.00
BAAA-8102054-PR	1953-56	pair	\$100.00

4852DHP



3537RCC



QUARTER PATCH-CAB CORNER REPAIR PANELS

1928-56 FORD PICKUP

A-1051-A	1928-29 Rear body Corner, L or R	each	\$45.50
A-870-B	1930-31 Rear body Corner, L or R	each	\$45.00
B-870	1932-34	pair	\$90.00
3537RCC	1935-37	pair	\$203.00
4047RCC	1940-41	pair	\$203.00
7C-8140302-PR	1948-52	pair	\$90.00
BAAA-8140302-PR	1953-56	pair	\$100.00



1928-1956 Pickup Truck Parts

1928-1956 Pickup Truck Parts



DOOR BOTTOM REPAIR PANELS

1928-1956 FORD PICKUP CALL FOR AVAILABILITY

281419	1928-29 pair	\$41.00
A-436-B	1930-31 6" tall. pair	\$50.00
A-436-IB	1930-31 Inner panel pair	\$50.00
B-836	1932-34 Pick-up, outer pair	\$65.00
B-836-I	1932-34 Pick-up, inner door bottoms pair	\$45.00
35370DSK	1935-37 Outer door skin pair	\$75.00
3537IDBOT	1935-37 Inner door bottoms pair	\$85.00
38470DSK	1938-47 Outer door skin pair	\$75.00
01C-836	1938-47 Outer door skin pair	\$95.00
3847IDBOT	1938-47 Inner door bottoms pair	\$95.00
BAAA-8120200	1953-56 Outer door skin pair	\$130.00
BAAA-8120120	1953-56 Inner door panels pair	\$90.00



ROCKER REPAIR PANELS

1928-1956 FORD PICKUP

3537RP	1935-37 pair	\$130.00
4047RP	1940-47 pair	\$75.00
4852RP	1948-52 pair	\$75.00
BAAA-8110110	1953-56 pair	\$100.00



LOWER REAR CAB PANELS

1928-1956 FORD PICKUP - repairs across rear bottom of cab

A-877-A	1928-29 Roadster pickup each	\$225.00
A-977-L	1928-29 Closed cab pickup each	\$225.00
A-850-B	1930-31 each	\$75.00
B-850	1932-34 each	\$75.00
3537LRCP	1935-37 each	\$80.00
4047LRCP	1940-47 each	\$80.00



TAILGATE PARTS

TM-109	1938-50 Tailgate chain	\$65.00
	Includes chain & cover, hook, bed mount bracket and latching link.		
10310	Inside latch	\$65.00



CAB MOUNTING WOOD

88033	1932-34 Oak kit	\$135.00
88034	1935-37 Hardwood kit	\$175.00
	All holes drilled. Set of two. Also sometimes used on 1938-41.		
88036	1938-41 Hardwood Cab Mounting Blocks	..	\$155.00
	Six piece set. Some cabs originally came with two long blocks and some came with these six short blocks. These work for both types.		

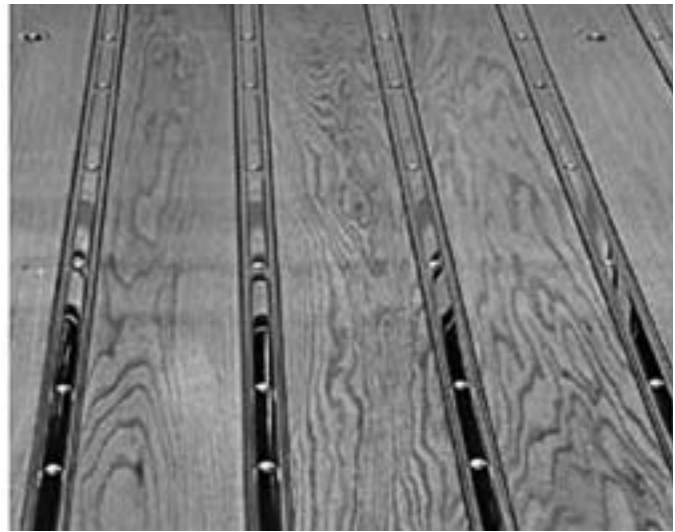

CUSTOM BED WOOD KITS

For all late 1931-50 Fords. An alternative kit to replace steel bed floor. Kit includes oak wood, steel strips, special spacers, bolts and brackets which make it appear to be factory.

Wood floor kit	\$449.00
Wood floor kit with stainless steel strips	...	\$449.00

The stainless steel strips come without mounting holes and are easily drilled and cut to length. Square punching is available at \$2.00 per strip. Please provide your hole location measurements.



TAILGATE PARTS

10315	1938-50 Tailgate end, Cast iron Primed	\$15.00
10215	Late 1931-36 Tailgate hinge	\$8.95
	Stamped steel. Primed. All holes drilled. (Three required per truck.) B78446		
10216	1937-52 Tailgate hinge	\$10.00
	Stamped Steel. All holes drilled. Primed. 81C830860		
	Stainless	\$20.00

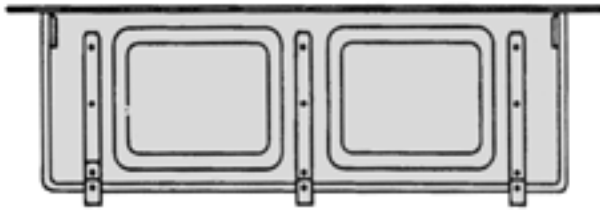

1931-34 FORD TAILGATE with Hinge Straps
46-3/4" wide- outer lip to outer lip

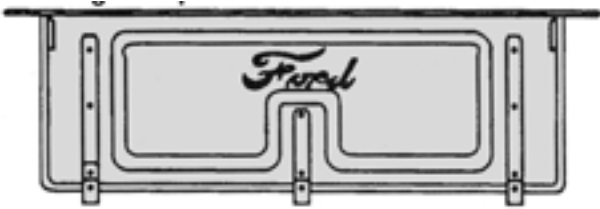

1935-36 FORD TAILGATE with Hinge Straps
46-3/4" wide- outer lip to outer lip



1937 FORD TAILGATE
46-3/4" wide- outer lip to outer lip

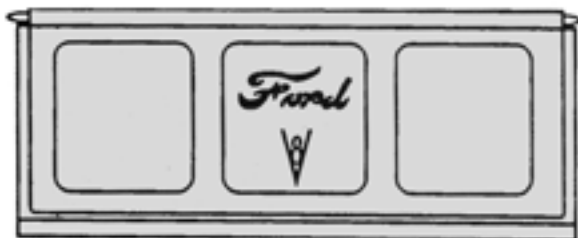

1938-40 FORD TAILGATE
46-3/4" wide- outer lip to outer lip. 81C-830700



FORD REPRODUCTION TAILGATES

Available for 1926 to 72 Ford and 1947-59 Chevy trucks. All die stamped steel with all the details of the original. Primed and ready to finish.

10137	1931-34 Ford	\$315.50
10138	1935-36 Ford	\$295.50
10139	1937 Ford	\$295.50
10140	1938-40 Ford	\$295.50
10141	1941 Ford	\$295.50
10142	1942-50 Ford	\$295.50
10143	1950-52 Ford	\$295.50
10144	1953-72 Ford	\$395.50
	1947-59 Chevy/GMC	starting at \$265.00



1941 FORD TAILGATE
46-3/4" wide- outer lip to outer lip. 11C-40700



1942-50 FORD TAILGATE
49-3/4" wide- outer lip to outer lip. 21C-8340700



1950-52 FORD TAILGATE
49-3/4" wide- outer lip to outer lip. 8C-40700



1953-72 FORD TAILGATE
50" wide- outer lip to outer lip. B7C-8340700A
(Dennis Carpenter)

1928-1956 Pickup Truck Parts

FORD 1/2 TON REPRODUCTION BED SIDES

Available for 1926 to 56 Ford trucks. All bed sides are die stamped steel with all the details of the original. Primed and ready to finish. Available with or without stake holes. Stake pockets are not included

1928-37 BED SIDES

10101	1928-31 LH (61" long)	Call for prices
10102	1928-31 RH (61" long)	Call for prices
10103	1931 Wide bed LH	\$349.00
10104	1931 Wide bed RH	\$349.00
10105	1932 LH	\$349.00
10106	1932 RH	\$349.00
10107	1932 LH short*	\$349.00
10108	1932 RH short*	\$349.00
10109	1933-34 LH	\$349.00
10110	1933-34	\$349.00
10111	1933-34 LH short*	\$349.00
10112	1933-34 RH short*	\$349.00
10113	1935-36 LH	\$349.00
10114	1935-36 RH	\$349.00
10115	1937 LH	\$349.00
10116	1937 RH	\$349.00

* 1932 Short- 55" long, 1933-34 Short- 60" long

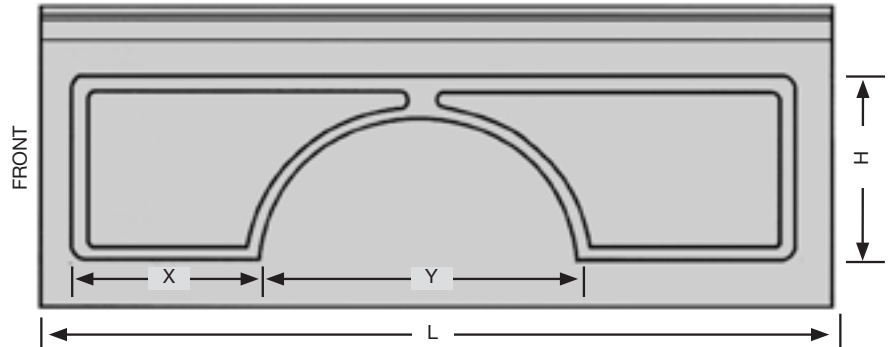

YEAR	X	Y	L	H
1928-31	4.0"	27.0"	56.5"	8.0"
1931 Wide bed	4.0"	31.0"	61.0"	12.0"
1932	4.0"	34.5"	65.5"	16.5"
1933-34	9.0"	34.5"	70.5"	16.5"
1936-36 #50-830500 16"	16.0"	37.0"	70.5"	16.5"
1937	16.0"	37.0"	74.5"	16.5"

All panels also have the correct stamped design in the wheel opening (approximately where the "Y" is located in the above drawing).

1938-50 BED SIDES

10117	1938-47 LH	\$349.00
10118	1938-47 RH	\$349.00
10121	1948-50 LH	\$349.00
10122	1948-50 LH	\$349.00

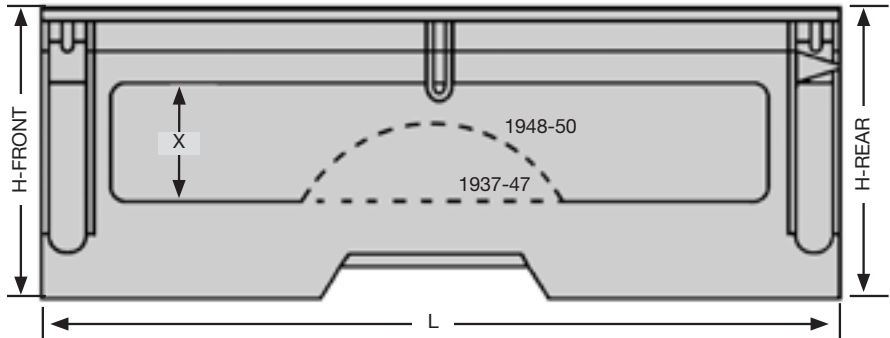

YEAR	H-FRONT	H-REAR	L	X	BOX WIDTH
1938-41 #81C830500	25.25"	25.25"	78.75"	12.0"	46.0"
1942-47 #81C830500	25.25"	25.25"	78.75"	12.0"	49.0"
1948-50	27.00"	25.25"	78.75"	12.0"	49.0"

1951-56 BED SIDES

10123	1951-52 LH	\$278.00
10124	1951-52 RH	\$278.00
10125	1953-72 LH	\$278.00
10126	1953-72 RH	\$278.00

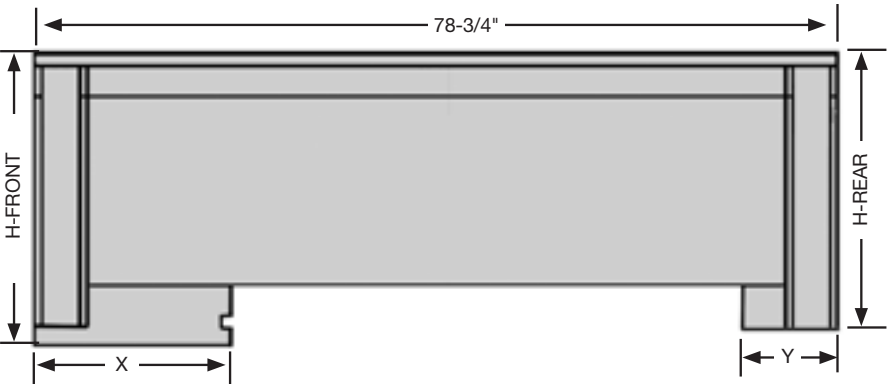

YEAR	H-FRONT	H-REAR	Y	X	BOX WIDTH
1951-52	27.75"	25.25"	5.50"	17.50"	49.0"
1953-72	27.75"	25.25"	8.25"	15.75"	49.0"

1928-1956 Pickup Truck Parts



COMPLETE UN-ASSEMBLED BED KITS-FORD

11113/1	1931 Wide bed	\$2,995.00
11115/1	1932 1/2 Ton (short version available)	\$2,995.00
11117/1	1933-34 1/2 Ton (short version available)	\$2,995.00
11119/1, 11121/1	1935-36, 1937	\$2,995.00
11123/1, 11121/1	1938-40, 1941	\$2,995.00
11127/1, 11129/1	1942-47, 1948-50	\$2,995.00
11131/1, 11133/1	1950-52, 1953-72	\$2,000.00

CHEVY/GMC

44113/3	1933-36 Smooth or Chevy tailgate	\$2,495.00
44115/3	1937-39 Smooth or Chevy tailgate	\$2,495.00
44117/3	1940 Smooth or Chevy tailgate	\$2,495.00
44119/3	1941-46 Smooth tailgate	\$2,495.00
44121/3	1947-50 Chevy or GMC tailgate	\$2,495.00
44121/3	1951-53 Chevy or GMC tailgate	\$2,495.00

Note: Chevy/GMC kits do not include bed wood.

COMPLETE PICKUP BED KITS

This is a complete kit with everything you need to assemble a new bed. Made of 16 gauge steel. Fender holes are not pre-drilled but everything is pre-fit to help assembly. Fenders are not included. Also available assembled.

Parts Included in kit -

- Front Bed Panel
- Pair of Bedside Assemblies
- Complete Sub-frame
- Tailgate - Now Available
- Pair Tailgate Chains
- Pair Tailgate Hinges
- Floor Adapter kit
- Set of Bed wood
- Set of Steel Strips
- Cap Strip for Back Edge of Floor

- Complete Bed Assembly Bolt Kit includes Fender Bolts & Rivets
- Pair of Lower Bed Extension Panels

Stainless options -

- Stainless Strips - add \$120.00
- Stainless Cap Strip - add \$25.00
- Stainless Strip Bolts - add \$35.00
- Stainless Bed Mount Kit - add \$45.00

1931-50 Ford complete assembled bed	\$3,495.00
1950-52 Ford complete assembled bed	\$3,495.00
1953-72 Ford complete assembled bed	\$3,495.00
1934-53 Chevy/GMC complete assembled bed	\$2,895.00
Crating charge for kit	\$150.00
Crating charge for assembled bed	\$200.00

1928-37 FORD PICKUP PARTS

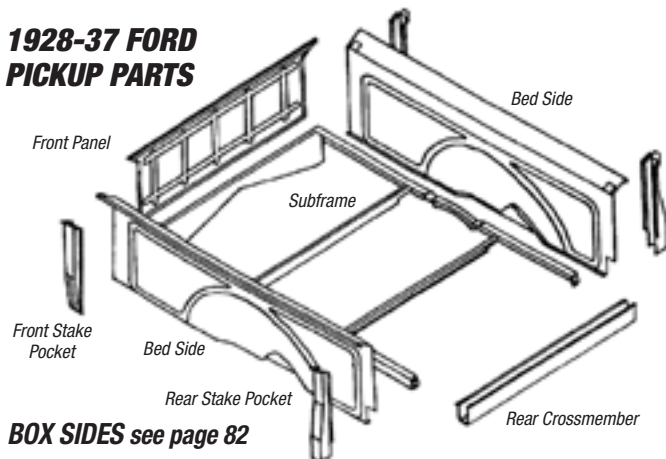

BOX SIDES see page 82

FRONT PANEL

10755	1928-31	each \$92.00
10756	1931 Wide bed	each \$215.00
10757	1932-37	each \$199.00

STAKE POCKETS

10267	1926-31 Front	each \$34.00
10268, 10269	1931-37 Front, rear	each \$34.00

CROSSMEMBERS

22001	1928-31	each \$30.00
22002	1931 Wide bed	each \$65.00
22004	1932	each \$65.00
22007	1933-34	each \$65.00

REAR CROSSMEMBER

20336	1931 Wide Bed	each \$72.00
20337	1932-37	each \$70.00

SIDE SUB-RAILS

1928-37 Left or Right	each \$125.00
-----------------------------	---------------

1938-56 FORD PICKUP PARTS

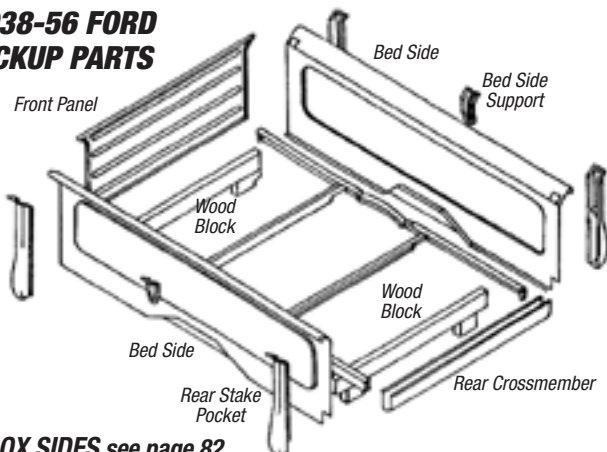

BOX SIDES see page 82

FRONT PANEL

10758	1938-41	each \$195.00
10759	1942-50	each \$150.00
10760	1950-72	each \$150.00

STAKE POCKETS

10270	1938-50 Front and rear same	each \$30.00
10271	1950-72 Front and rear same	each \$24.00

FRONT & CENTER CROSSMEMBER

22011	1935-41	each \$75.00
22015	1942-50	each \$75.00
22018	1950-72	each \$50.00

REAR CROSSMEMBER

20338	1938-41	each \$ 60.00
20339	1942-50	each \$ 80.00
20340	1951-72	each \$ 80.00

SIDE SUB-RAILS

1938-50	each \$125.00
---------------	---------------

BED SIDE SUPPORT

10304	1937-50 Left or right	each \$17.00
-------	-----------------------------	--------------

Call 402.886.2275 or click: www.heinzmanstreetrods.com

1928-1956 Pickup Truck Parts

487-1



520-1



C-Ac497-1



JOHNSON RADIATORS

Walker Cobra Radiators are made from the finest material available -- copper core, brass tanks and heavy-duty steel side brackets. Each Walker Radiator comes complete with all connections, ready to bolt in your application. They all include an oil cooler for automatic transmissions. Walker Radiators are guaranteed for a period of three years from the date of shipment.

COBRA STANDARD SERIES

Walker Cobra Standard Series Radiators are designed to cool basic stock small block engines. They are not designed for engines that have been bored or modified or expected to run hot.

COBRA STANDARD SERIES

FORD

C-481-1	17-23 'T' Shells	N/A
C-481-2	24-27 'T' Shells	N/A
C-487-1	28-29 Model A.	N/A
C-487-2	30-31 Model A.	N/A
C-491-2	32 Ford.	N/A
C-498-1	33-34 Ford.	N/A
C-488-1	35 Ford.	N/A
C-494-1	36 Ford.	N/A
Z-495-1	37-39 Standard	N/A
C-497-1	39-40 Ford.	N/A
C-496-1	41 Ford.	N/A
C-493-1	42-48 Ford.	N/A
C-489-1	42-52 Ford Pickup	N/A

CHEVY

C-512-1	32 Chevy	N/A
C-511-1	33 Standard.	N/A
C-510-1	33 Master	N/A
C-508-1	34-35 Master.	N/A
C-509-1	34-35 Standard.	N/A
C-505-1	36 Chevy	N/A
C-501-1	37 Chevy	N/A
C-502-1	38 Chevy	N/A
C-503-1	39 Chevy	N/A
C-504-1	40-41 Chevy	N/A
C-513-1	46-48 Chevy	N/A
C-567-1	55-57 Chevy	N/A
C-519-1	39-59 Chevy Pickup	N/A

COBRA Z SERIES

Walker Cobra Z Series Radiator are heavy-duty units designed to cool modified small blocks, 400 inch small block Chevys, supercharged engines, big block Chevys, big block Fords, big block Mopars, Ford Flatheads, or any engine that has been bored or modified.

COBRA Z-SERIES (substitute a "Z" for the "C" in the part number above) . . . \$1,275.00

WALKER COBRA COOL MATE AIR CONDITIONING RADIATORS

The Walker Cobra Cool Mate Series is a street rod radiator and air conditioning condenser built in one! No alterations to the grill are required. It is a simple bolt-in application and guaranteed to cool. Securely mounted for long lasting durability, it features a heavy duty A.C. condenser with over 220 sq. in. of air conditioned cooling efficiency. Includes automatic transmission cooler. Available in standard duty or Heavy-duty "Z" Series as above.

STANDARD DUTY COOLMATE (substitute a "C-AC" for "C" in the part no. above) \$929.00

HEAVY-DUTY Z LINE COOLMATE (substitute a "Z-AC" for "C" in the part no. above) . \$1,475.00

NOTE: Prices subject to change because of the fluctuating price of brass.

FAN SHROUDS

This is an excellent way to improve the air flow and over all dependability of the cooling system. Eliminates chips and debris thrown by exposed fans. Fits only cars with Walker brand radiators.

WS-40	1939-40 Ford Dlx, 1941 Ford.	\$125.00
WS-50	1933-36 Ford, 1932-41 Chevy	\$125.00
WS-55	1932 Ford 22" H x 17" W	\$125.00
WS-55A	1937-40 Chevy Pickup 22" H x 17-1/2" W	..	\$125.00
WS-60	1937-39 Ford Std 23" H x 16" W	\$125.00
WS-70	1942-48 Ford, 1946-48 Chevy & 1947-53 Chevy Pickup 19-1/4" H x 20-1/8" W	\$125.00





COMBINATION ELECTRIC FAN AND SHROUD

An air flow package designed for when engine compartment space is limited. Ultra thin design only 2-1/8" thick. Finger guard protectors and an adjustable thermostat extra.

- CC1750** High volume single 17" diameter fan
2-1/2" thick at center (21" H x 18" W) \$450.00
- CC1740** 40 Ford 25" W x 17" H. \$450.00
- CC1770** 21" W x 18" H \$450.00
- 24675VUT** Thermostat switch, manually adjustable \$40.00
- Relay kit, heavy-duty 70 amp \$65.00



PRC ALUMINUM RADIATORS

Performance Rod and Custom Radiators are made from the finest aluminum alloys available. PRC's furnace-brazed cores with two rows of one inch tubes help your car or truck run cool in extreme conditions. PRC universal side mounting brackets allow a wide range of adjustments and easy installation.

Options include: Custom aluminum shroud, Spal Electric Fans, Automatic Transmission cooler, A/C Condenser, Coolant Recovery Tanks, Complete Polished finish.

Available for:	1968-76 Torino	1967-69 Camaro
	1917-56 Ford Cars	1917-56 Ford Trucks
	1964 & up Mustangs	1932-59, 67-72 Chevy Trucks
	1955-70 Fairlanes	1929-70 Chevy
	1964-72 Chevelle	
	1959-74 Galaxie	1962-67 Nova

Prices start at \$605.00
Prices start at with transmission cooler \$675.00



STAINLESS STEEL FLEX-FAN

Optimum engine cooling from newly engineered fan. Flex blade design gives more cooling at low RPM. Blades flatten out at higher speeds.

- AT-17** 17" Diameter Flex-Fan . . \$75.00
- AT-17R** 17" Reverse fan, for serpentine drive \$75.00



RADIATOR RECOVERY TANK KIT

Polished stainless steel recovery tank from the Deuce Factory. One quart capacity fits any radiator with flanged sides, and clean stainless steel brackets makes installation a snap.

- 3367** Radiator recovery tank \$69.00



CHROME PRESSURE CAP

Custom designed to add that final touch of class! For open or closed systems.

- WC-7** 7 LB. \$22.95
- WC-15** 15 LB. \$22.95



RADIATOR SUPPORT RODS

- A-8133-SS** 1928-31, Stainless. pair \$40.00
- B-8133-C** 1932-39 Standard, stainless. pair \$40.00
- B-8130-S** Radiator mounting kit
Pads, Springs, Nuts & Bolts \$5.00

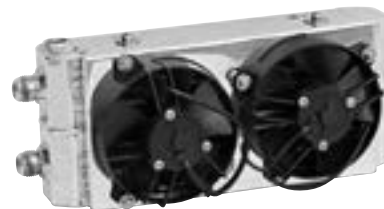

EXTREME DUTY OIL COOLER

Cools engine oil in high horsepower applications and aids overall cooling. Available with #10AN, #12AN or #16AN fittings.

- 29307** Engine oil cooler with fans \$455.00
- 29307** Engine oil cooler without fans \$289.00



BILLET PRESSURE CAP

This 16 LB. pressure cap is designed for aluminum radiators. Smooth or grooved design.

- 2613009** 16 LB. \$22.00

Call 402.886.2275 or click: www.heinzmanstreetrods.com

Radiators and Cooling System Parts



ROCK VALLEY STAINLESS STEEL FUEL TANKS

Premium quality all stainless steel replacement gas tanks made of 304 stainless steel. All tanks come fully baffled, with dual outlets and set up to accept your choice of sending unit. The Ford tanks are available in 15 or 20 gallon size and the 1932 to 34 have spill proof caps. The 1932 Ford tank comes with a fiberglass cover.

FORD

1928-31	15 gallon	\$1,045.00
1932	15 gallon	\$1,045.00
1933-34	15 gallon	\$1,045.00
1935-40	15 gallon	\$1,045.00
1941-48	Stock capacity	\$1,045.00
1949-51	Mercury stock capacity	\$1,045.00

CHEVY

1931-32	20 gallon	\$1,050.00
1933-36	18 1/2 gallon	\$1,050.00
1937-40	Sedan 18 gallon	\$1,050.00
1937-40	Coupe Stock	\$1,050.00
1941-48	Coupe 20 gallon	\$1,050.00
1955-57	Stock capacity	\$1,050.00
1953-67	Corvette stock capacity	\$900.00
	Tank vent	\$15.00
	EFI pump installed	\$325.00



"TANKS" POLYETHYLENE FUEL TANKS

A polyethylene tank that has the contours of a stock tank but the capacity has been expanded to 17 gallon. The tank is dent and condensation proof. All tanks feature a "baffle-tunnel" and accept aftermarket senders. EFI fuel pump modules available. Many of the same applications and details of the steel "Tanks" on the next page.

1933-56 Ford	\$269.00
1933-55 Ford pickups	\$269.00
1935-57 Chevy	\$269.00
Gas gauge sender	\$55.95

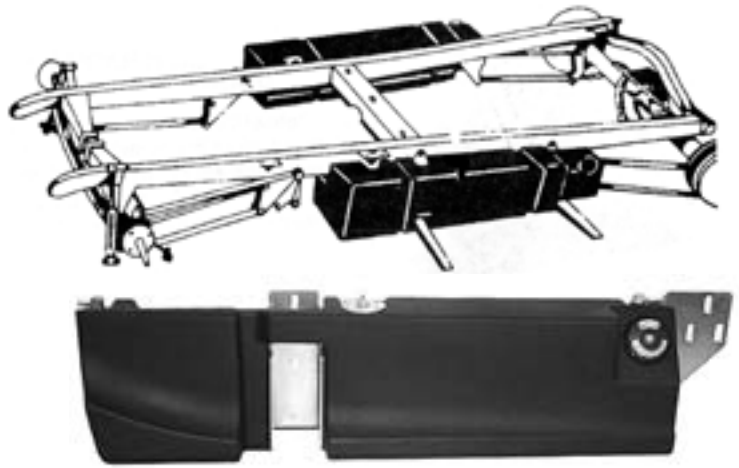

MODEL A GAS TANKS

Patented twin auxiliary saddle tanks that fit any stock or Chassis Engineering type reproduction frame using stock running board brackets. You end up with more room to install a custom dash and air conditioning. No more hazardous "back seat" tanks. Easily installed, out of sight, out of the way. Not for fuel injection Kit comes complete with:

- * Two strong, no-dent polyethylene saddle tanks with push-thru caps
- * Sturdy mounting straps
- * Changeover valve, 240-33 ohm fuel sending units
- * Gas caps, filler necks, grommet material
- * Detailed, easy-to-follow instructions

1928-29	Model A Gas Tanks 7 gallons/side	\$495.00
1930-31	Model A Gas Tanks 6.5 gallons/side	\$495.00



VINTIQUE 1932 FORD FUEL TANKS

An exact steel reproduction of the stock Ford tank. includes pickup and rollover valve. Accepts 5-hole 12 volt sending units.

VIB-9002	1932 Ford	\$450.95
----------	-----------	-------	----------

"TANKS" UNIVERSAL STEEL FUEL TANK

This fuel tank measures 36" x 10" x 14" and holds 18 gallons. Available alloy coated steel or stainless steel. Fully baffled.

Tank comes complete with: Billet Cap, Rollover valve, vent, bolt-on neck, accepts all popular senders, top mount pickup tube, EFI anti-starvation tray.

U2-A-T	Coated alloy steel	\$279.00
U2-SS-T	Stainless steel	\$395.00



Fuel Tanks and Parts



"TANKS" ALLOY COATED STEEL FUEL TANKS

Die-stamped alloy coated steel tanks look original but are 1-1.5" deeper for added capacity and have added features: top mounted pickup and vent, internal reservoir for EFI, pickup tube and return line, accepts aftermarket sending units. In-tank pumps optional.

Almost all tanks available in stainless steel, too. Please call.

32Z-S	1932 Ford stock	11 Gallon	\$365.00
32Z-D2	1932 Ford stock	14.5 Gallon	\$365.00
34G	1933-34 Ford	16 Gallon	\$279.00
34G-PT	1933-37 Ford trucks,	16 Gallon	\$279.00
35G	1935-36 Ford,	16 Gallon	\$279.00
37G	1937 Ford,	16 Gallon	\$279.00
40G	1938-40 Ford,	16 Gallon	\$279.00
48G	1941-48 Ford	17 Gallon	\$279.00
51P	1949-51 Ford	stock capacity	\$279.00
TF31C	1955-56 Ford	Original	\$279.00
F100P	1953-55 Ford Pickups,	stock capacity	\$175.00
TF28E	1964-68 Ford Mustang	Original 16 gallon	\$150.00
TF28C	1969 Ford Mustang	Original 20 gallon	\$150.00
TF28D	1970 Ford Mustang	Original 22 gallon	\$175.00
32C-A	1928-32 Chevy	15 Gallon	\$300.00
34STD-A	1934-35 Chevy Standard	15 Gallon	\$300.00
36-GG	1935-36 Chevy Master	stock 14 Gallon	\$269.00
37-GG	1937 Chevy	stock 14 Gallon (ex bus coupe)	\$269.00
38-CG	1938-39 Chevy	stock 14 Gallon (ex bus coupe)	\$269.00
48R-CG	1941-48 Chevy	stock 16 Gallon	\$175.00
48R-CGX	1941-48 Chevy	extra capacity	\$195.00
51-CGX	1949-52 Chevy	extra capacity	\$195.00
53-CGX	1953-54 Chevy	extra capacity	\$195.00
	1955-57 Chevy Stock	Capacity	\$230.00

Gas Gauge Sender **\$34.95**

GMC, Buick, Pontiac, Oldsmobile, Mopar, Mercury tanks also.



91A-9080



3207-A



Original 1932-48 Gas Cap

GAS TANK NECK GROMMET

Works well on 1933 to 40 Fords and many others.

91A-9080 Rubber gas tank grommet \$8.00

GAS CAPS FOR 1932 - 48 FORD

For stock filler neck

Stainless steel cap (vented) \$15.00

GAS CAP

3207-A Aluminum screw-on gas cap \$16.50
3208 Weld-on bung, works with 3207A \$13.50



"TANKS" GSA IN-TANK EFI PUMPS

These pumps work in "Tanks" gas tanks that have a pre-installed reservoir tray. These trays must be used to prevent fuel starvation.

Flange includes a pickup and return line and in-tank wire harness. Pumps are made in the USA and rated up to 600 horsepower.

**GPA-4 68 GPH @ 65 PSI
 thru 62 GPH @ 60PSI \$249.00**

"TANKS" PA-SERIES IN-TANK PUMPS

These EFI fuel pump modules work in most gas tanks. A hole may have be cut for the flange, but everything bolts together. An adjustable heavy-duty mounting plate and anti-fuel starvation reservoir tray are included. These trays must be used to prevent fuel starvation.

Flange include a pickup and return line, vent fitting and in-tank wire harness. Pumps are made in the USA and rated from 40 to 100 PSI. They run at the pressure required by your EFI regulator

GPA-4 68 GPH @ 65 PSI thru 62 GPH @ 60PSI \$249.00
GPA-1-TBI Throttle Body Injection \$249.00



"TANKS" UNIVERSAL STEEL FUEL TANK

This universal tank measures 27" x 17" x 9.5" and holds 14 gallons. Available with a bolt on 3" threaded filler neck or 2" neck with 6" connecting hose. This tank uses the GA-series pump with anti-starvation tray.

Tank comes complete with: Billet Cap, Rollover vent valve, accepts all popular senders, top mount pickup tube.

UT Tank with 3" threaded neck \$269.00
UT-H Tank with 2" hose connection \$269.00

GAS TANK SEALER

Designed to seal inside of gas tank and eliminate rust floating around in tank

Gas tank sealer \$35.00

Call 402.886.2275 or click: www.heinzmanstreetrods.com

SANDERSON HEADERS

There are too many applications to list here- Please call if you don't see what you need!

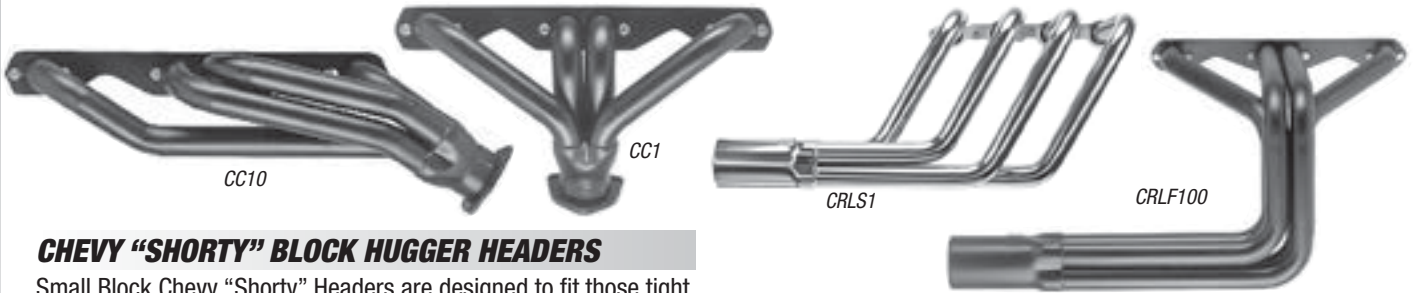

CHEVY "SHORTY" BLOCK HUGGER HEADERS

Small Block Chevy "Shorty" Headers are designed to fit those tight applications that other headers won't fit. Tucks within 1/8" of the block and collector flange exits next to the oil pan gasket. Suited for street rods, muscle cars and some late model pickups. Patented machined 3/8" flange requires no gaskets, just a bead of high-temp silicone. Prices are for plain steel.

CC1	Small Block , 1-1/2" tubes, center outlet 1927-48 Ford Cars	\$235.00
CC1-5/8	Small Block , 1-5/8" tubes, center outlet 1927-48 Ford Cars	\$265.00
CC1-3/4	Small Block , 1-3/4" tubes, center outlet 1927-48 Ford Cars, 62-67 Nova/Must II susp	\$315.00
CC10	Small Block , 1-1/2" tubes -64-up Chevelle, rear outlet	\$265.00
CC1AP	Chevy Small Block -angle plug.....	\$269.00
LS158	Chevy LS , 1-5/8" tubes, street rods, early pickups .	\$335.00
CS1LS1	Chevy LS , 1-1/2" tubes, 64-up Chevelle.....	\$335.00
CC1T	Chevy Small Block , 1-1/2" tubes extra tight for "T"s, "A"s and 40s Fat Fender rods	\$265.00
CC50	Chevy Small Block -1949-54 Chevy Cars.....	\$265.00
CC14	Chevy Small Block -1962-67 Chevy Nova	\$265.00
BB1	Chevy Big Block , 1-7/8" tubes, most street rods .	\$315.00
BB6	Chevy Big Block , 1-7/8" tubes, 55-57 Chevy.....	\$355.00
	HPC Coated	add \$200.00

CHEVY FULL LENGTH HEADERS

Full length block hugger header is designed for big horsepower small block Chevys and tight applications. Its 16 gauge tubes with tuck in extremely close to the block and have excellent ground clearance. Patented machined 3/8" flange requires no gaskets, just a bead of high-temp silicone. Gaskets, bolts and street hookups are included. Prices are for plain steel.

C3	Small Block , 1-1/2" tubes, most street rods . . .	\$375.00
C32	Small Block , 1-5/8" tubes, most street rods . . .	\$405.00
C33AP	Small Block angle plug heads , 1-3/4" tubes, most street rods	\$405.00
C56	Small Block , 1-3/4" tubes, 1955-56 Chevys . . .	\$375.00
BB5	Big Block , 1-7/8" tubes, most street rods	\$365.00
BB6	Big Block , 1-7/8" tubes, 1955-56 Chevys.....	\$365.00
C567F	Fender Well Small Block 1-3/4" tubes, 1955-56 Chevys Gasser Style	\$435.30
	HPC Coated	add \$250.00

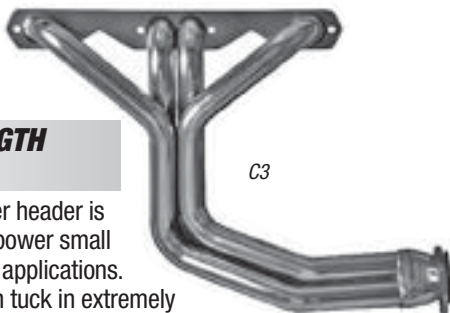

ROADSTER HEADERS

Roadster headers fits any Model T through 1934 fenderless application with plenty of front tire clearance. Ceramic coated.

CBR100	SB Chevy , 1-5/8" tubes, w/ 26" mufflers.....	\$829.00
CBR101	BB Chevy , 1-7/8" tubes, w/ 26" mufflers.....	\$879.00
CRLS1	Chevy LS-Series , 1-5/8" tubes, w/ 26" mufflers .	\$829.00

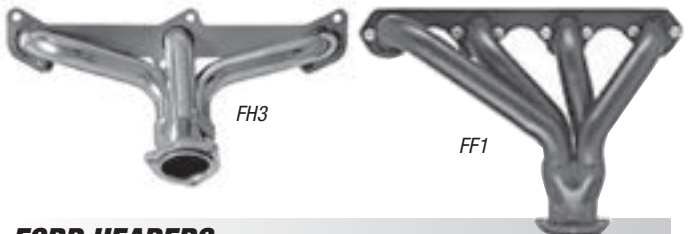

FORD HEADERS

For small block Ford Windsors (289-302, 351W). Patented machined 3/8" flange requires no gaskets, just a bead of high-temp silicone. Prices are for plain steel. Complete with street hookups, gaskets and special header bolts.

FF1	SB Ford block huggers , 1-1/2" tubes, center outlet most street rods	\$310.00
FF2	SB Ford block huggers , 1-1/2" tubes, rear outlet most street rods	\$310.00
FF3	SB Ford block huggers , 1-1/2" tubes, rear outlet 64-68 Mustang	\$310.00
F302	SB Ford full length , 1-1/2" tubes, most street rods and early pickups	\$380.00
FH3	Flathead Ford , 1-1/2" tubes, center outlet . .	\$310.00
FF4.6	Modular Ford block huggers , DOHC 1-1/2" tubes, rear outlet most street rods	\$380.00
	HPC coated	add \$200.00



CLASSIC HOT ROD ENGINES

Sanderson's patented machined 3/8" flange requires no gaskets, just a bead of high-temp silicone. Prices are for plain steel. Complete with street hookups, gaskets and special header bolts.

BNH1	Buick "Nailhead" block huggers , 1-1/2" tubes, center outlet, most street rods	\$355.00
DD3	Early Chrysler Hemi block huggers , 331-392 1-7/8" tubes, most street rods	\$355.00
	HPC coated	add \$200.00

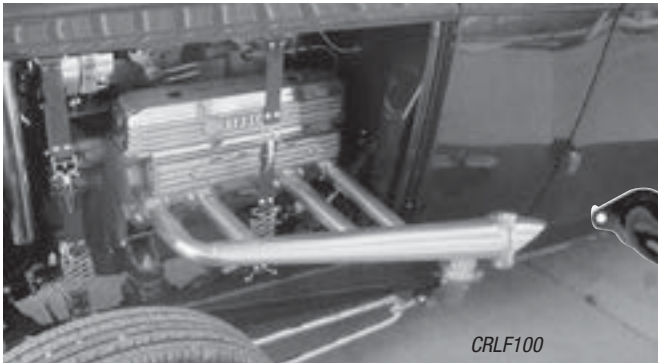

LIMEFIRE ROADSTER HEADERS

Roadster headers fits any Model T through 1934 fenderless application with plenty of front tire clearance. Ceramic coated. Headers include header bolts and standard blockoff plate.

Sanderson Features: •16-Gauge Primary and Collector Tube Thickness
• 3/8" Thick Flange •Patented Flange Design Requires NO Gaskets
• Tightest Fitting Header Available Anywhere! • Made in the USA

- CRLF100** SB Chevy, 1-5/8" tubes, "Limefire" style **\$680.00**
- CRLF101** BB Chevy, 1-7/8" tubes, "Limefire" style **\$750.00**
- LSLF101** Chevy LS Series, 1-5/8" tubes, "Limefire" style . **\$750.00**
- CRLF409** Chevy 348-409, 1-5/8" tubes, "Limefire" style .. **\$750.00**
- FRLF100** SB Ford, 1-5/8" tubes, "Limefire" style **\$750.00**
- FHLF100** Flathead Ford, 1-5/8" tubes, "Limefire" **\$750.00**
- FYLF100** Ford Y-Block, 1-5/8" tubes, "Limefire" **\$750.00**
- DRLF392** Early Hemi , 1-5/8" tubes, "Limefire" **\$750.00**

LIMEFIRE MUFFLERS

Designed for Limefire and Roadster headers

- GMP350**pair **\$65.00**



COPPER COLLECTOR GASKETS

Solves the collector leak problem for good! The soft copper material forms to the flange surface and won't blow out like fiber gaskets. Can be annealed and used over again.

- 2.5, 3.0 or 3.5" . . . pair **\$25.00**



BLOCK OFF PLATES

Perfect for capping off Sanderson roadster style headers. Polished machined cast aluminum.

- LFBP** pair **\$150.00**



SANDERSON ANGLE HEADER REDUCERS

Designed for tight fitting block hugger headers to angle the exhaust away from the oil pan for an easier installation. Plain steel.

- 2.5 or 3.0"pair **\$65.00**

LIME FIRE HEADER TURNOUTS

Gives the open header look for Sanderson roadster style headers. Works with block-off plates or leave open. 3 or 4 bolt.

- LFTO** Plain steel. .pair **\$110.00**
- Ceramic coated **\$185.00**



SANDERSON HEADERS

There are too many applications to list here- Please call if you don't see what you need!



GM LS-SERIES ENGINE HEADERS

The LS150 is designed to fit a variety of applications using GM LS-Series engines. With an all new flange and reworked tube bends for a tight fit, our LS150 header provides ample spark plug clearance to fit a variety of street rod applications. The 1½" primary tube diameter and 2½" collector are perfect for a stock to mild LS engine. Comes with all hardware necessary for installation. NOTE: For higher power output applications, this header is also available in 1-5/8" (#LS158) or 1-3/4" (LS134) primary tube diameters with a 3.0" collector.

- CC1LS1** Chevy LS, 1-1/2" tubes, "blockhugger" shorty. . . **\$595.00**
- LS150** Chevy LS, 1-1/2" tubes, "blockhugger" **\$595.00**
- LS158** Chevy LS, 1-5/8" tubes, "blockhugger" **\$595.00**
(coated headers)

LS19-158

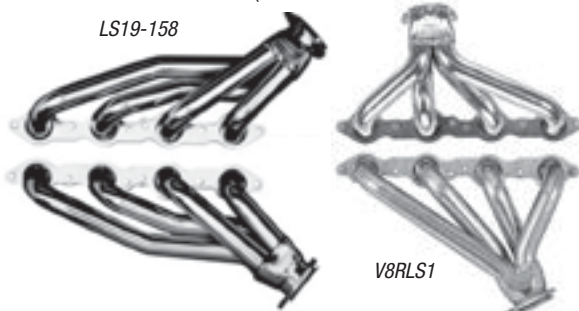

V8RLS1

- LS10-158** Chevy LS, 1-5/8" tubes, swept back design . . . **\$595.00**
- V8RLS1** Chevy LS, 1-1/2" tubes, many street rods/trucks **\$595.00**
(coated headers)



DYNATECH BLOCK HUGGER HEADERS

Dynatech's all stainless steel block hugger header is designed to fit in tight applications and still make good power. The flange is 3/8" thick, has finished welds and is machine ground for a leak-free seal. Includes 2" reducer cones and gaskets. 3/8" Flange, 1-5/8" Primaries, 2-1/2" Collector, 2" Reducer Cones

- 730-10010** Small Block Chevy polished stainless. **\$495.95**

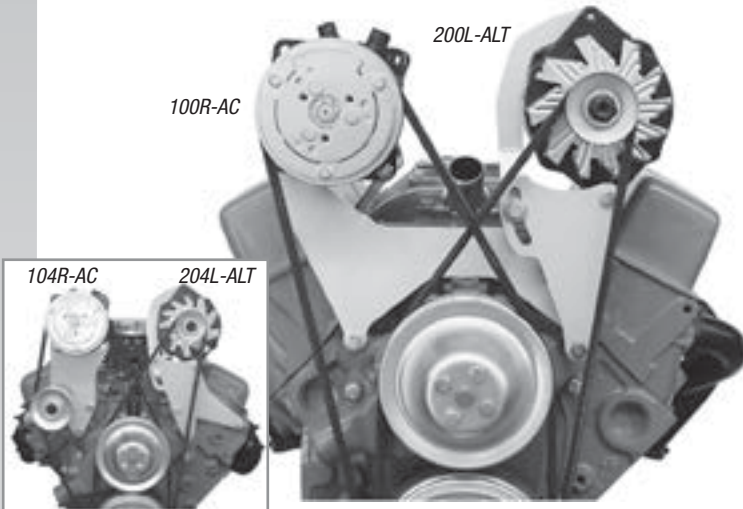

ALAN GROVE ALTERNATOR & AIR-CONDITIONING MOUNTING BRACKETS

Alan Grove brackets offer straight forward engineering and quality craftsmanship at an affordable price. All brackets are made from steel plate, T.I.G. welded and hand finished. All hardware, instructions and belt recommendations are included. Chevy kits listed are for short water pumps. Long water pump kits are also available.

A/C AND ALTERNATOR BRACKETS

SMALL BLOCK CHEVY bolts to top water pump and intake bolts

100R-AC	A/C bracket, Right	\$105.00
100L-AC	A/C bracket, Left	\$105.00
200R-ALT	Alternator bracket, Right	\$95.00
200L-ALT	Alternator bracket, Left	\$95.00
	Combination alternator-A/C Brackets	\$195.00
	Extra clearance brackets	\$195.00

BIG BLOCK CHEVY bolts to heads and top water pump bolts

104R-AC	A/C bracket right	\$105.00
204L-ALT	Alternator bracket left	\$90.00

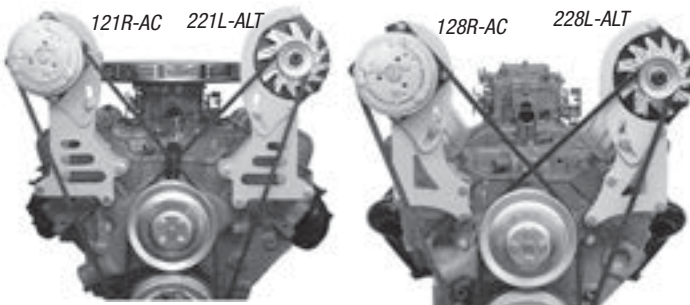

HEAD MOUNT A/C AND ALTERNATOR BRACKETS

Bolts to heads and top water pump bolts instead of intake manifold.

SMALL BLOCK

128R-AC	A/C bracket 1969 and newer, GM aluminum	\$99.00
129R-AC	A/C bracket 87-up iron & Vorteck	\$99.00
228L-ALT	Alternator Bracket	\$99.00

BIG BLOCK extra clearance

121R-AC	A/C bracket	\$99.00
221L-ALT	Alternator bracket	\$99.00

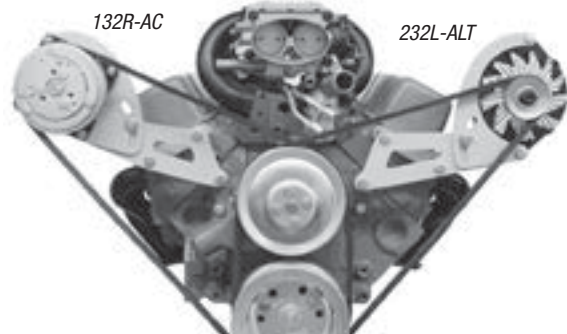

LOW HOOD CLEARANCE A/C AND ALTERNATOR BRACKETS

Designed for cars with a wide engine compartment and low hood clearance, Vettes, Camaros, Trucks, 50 - 60's cars, etc. The alternator bracket will fit all 1969 and newer heads. The small block A.C. Compressor bracket fits all G.M. aluminum heads including the fast-burn aluminum heads and may be used on 1969 thru 1986 cast iron heads by drilling and tapping one hole for the upper mounting point.

SMALL BLOCK These brackets bolt to the head and top water pump bolt holes.

132R-AC	A/C bracket	\$104.00
232L-ALT	Alternator brkt all 1969 and newer heads	\$104.00
133R-AC	A/C bracket 87-up iron & Vorteck	\$104.00

BIG BLOCK These brackets bolt to the head and top water pump bolt holes.

118R-AC	A/C bracket	\$104.00
218L-ALT	Alternator bracket	\$104.00

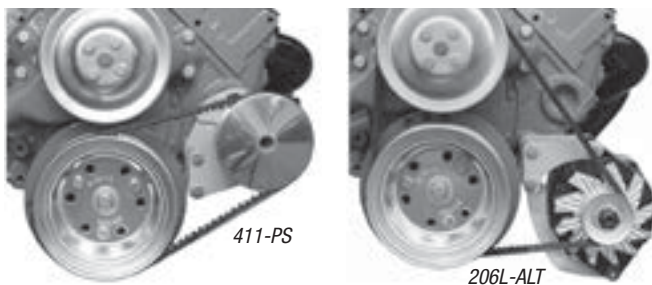

LOWER ALTERNATOR AND POWER STEERING BRACKETS

SMALL BLOCK

206L-ALT	Low alternator mount, left	\$75.00
206L-ALT	Low alternator mount -lower and tighter	\$80.00
209L-ALT	Low alternator mount for GM-CS130 Alt.	\$80.00
400L-PS	Power steering bracket, left	\$80.00
409L-PS	Power steering bracket, left, Type II pump	\$80.00

BIG BLOCK

208L-ALT	Low alternator mount, left	\$75.00
210L-ALT	Low alternator mount for GM-CS130 Alt.	\$80.00
430L-PS	Power steering bracket, left	\$80.00
415L-PS	Power steering bracket, left, Type II pump	\$80.00



SMALL BLOCK FORD A/C BRACKET

Brackets bolt to 289, 302, 351 Windsor heads and adjusts front to rear for different timing cover and pulley combos.

105L-AC	\$110.00
105R-AC	\$110.00



CONCEPT ONE "VICTORY SERIES" PULLEY SYSTEM

Victory Series serpentine pulley system is designed to keep the A/C compressor, alternator and power steering pump tucked within the boundary of the engine block. These kits are intended to fit a wide variety of applications from street rods to late model trucks as long as there is sufficient room between the engine and the radiator.

Kits include • Polished Sanden A/C compressor • New Delphi PS pump with billet reservoir • Edelbrock water pump • 105 amp polished alternator • billet crank, water pump, PS pulleys • billet brackets • alternator fan and pulley cover • compressor cover • belt and tensioner • chrome hardware. Available polished, machined finish or anodized clear or black.

SCV01P	Chevy SB w/PS, Polished or anodized	\$2,495.00
SCV01M	Chevy SB w/PS, Machined.	\$2,145.00
SCV02P	Chevy SB w/o PS, Polished or anodized.	\$1,995.00
SCV02M	Chevy SB w/o PS, Machined	\$1,745.00
BCV01P	Chevy BB w/PS, Polished or anodized	\$2,245.00
BCV01M	Chevy BB w/PS, Machined	\$2,045.00
SCV02P	Chevy BB w/o PS, Polished or anodized	\$1,895.00
SCV02M	Chevy BB w/o PS, Machined	\$1,745.00
LSV01P	Chevy LS w/PS, Polished or anodized	\$2,645.00
LSV01M	Chevy LS w/PS, Machined.	\$2,375.00
LSV02P	Chevy LS w/o PS, Polished or anodized.	\$2,295.00
LSV02M	Chevy LS w/o PS, Machined	\$2,045.00

CHEVY ENGINE PULLEYS

Factory GM black steel pulleys. Small block and big block with short water pump. Serpentine pulley sets are for long water pumps.

500	2 groove water pump, Small/Big Block	\$50.00
501	2 groove crank, Small Block	\$45.00
501B	2 groove crank, Big Block.	\$55.00
502	1 groove crankshaft power steering Small/Big Block	\$40.00
506	2 groove Power steering, bolt-on.	\$40.00
509	2 groove Power steering, press-on.	\$47.00
510	Serpentine set, Small Block water pump, crankshaft power steering and alternator.	\$135.00
511	Serpentine set, Small Block water pump, crankshaft and alternator	\$100.00



"Please call for dimensions and details on any of these kits."

CONCEPT ONE "STREET ROD" PULLEY SYSTEM

Street Rod Kits are one belt serpentine kits designed for street rods and other vehicles with tight engine compartments. These compact setups keep the A/C compressor and alternator in close to the engine and set back as far as possible to allow clearance for radiators and electric fans. Reverse flow water pumps are used for improved cooling. Kits are available for standard small block cast iron and aluminum heads, as well as Vortec heads.

Kits include • New Delphi PS pump with billet reservoir • Edelbrock water pump • billet crank, water pump, PS pulleys • billet brackets • alternator fan and pulley cover • compressor cover • belt • chrome hardware. Available polished or machined.

SCR01P	Chevy SB w/PS, Polished.	\$1,295.00
SCR01M	Chevy SB w/PS, Machined.	\$1,150.00
SCRV01P	Chevy SB Vortech w/PS, Polished.	\$1,295.00
SCRV01M	Chevy SB Vortech w/PS, Machined.	\$1,150.00
SCR02P	Chevy SB w/o PS, Polished	\$895.00
SCR02M	Chevy SB w/o PS, Machined	\$750.00
SCR02P	Chevy SB Vortech w/o PS, Polished	\$895.00
SCR02M	Chevy SB Vortech w/o PS, Machined	\$750.00
BCR01P	Chevy BB w/PS, Polished.	\$1,295.00
BCR01M	Chevy BB w/PS, Machined	\$1,150.00
SCR02P	Chevy BB w/o PS, Polished	\$895.00
SCR02M	Chevy BB w/o PS, Machined	\$750.00

CONCEPT ONE SMALL BLOCK FORD PULLEY SYSTEM

These one belt systems fit a wide variety of applications including street rods, trucks, Mustangs and practically anything else a small block Ford will fit into. **Versions for short and long water pump and without power steering and/or AC.**

Kits include • Polished Sanden A/C compressor • New Delphi PS pump with billet reservoir • 105 amp polished alternator • billet crank, water pump,



PS pulleys • billet brackets • alternator fan and pulley cover • belt • compressor cover • chrome hardware. Available polished or machined. **Specify 289/302 or 351 Windsor. Also available for Cleveland, FE and 429/460 Big Blocks.**

SFL01P	Ford SB w/PS, long WP Polished.	\$2,195.00
SFL01M	Ford SB w/PS, long WP Machined	\$1,995.00
SFM01P	Ford SB w/PS, short WP Polished	\$2,195.00
SFM01M	Ford SB w/PS, short WP Machined.	\$1,995.00
SFL02P	Ford SB w/o PS, long WP Polished	\$1,795.00
SFL02M	Ford SB w/o PS, long WP Machined	\$1,595.00
SFM02P	Ford SB wo /PS, short WP Polished	\$1,795.00
SFM02M	Ford SB w/o PS, short WP Machined	\$1,595.00

Call 402.886.2275 or click: www.heinzmanstreetrods.com

Engine Accessory Drives and Pulleys

THE VINTAGE AIR FRONT RUNNER SERPENTINE DRIVE SYSTEM

FOR ANY HOT ROD, CUSTOM, OR CLASSIC TRUCK.

Vintage Air's Front Runner Drive System was engineered to convert any small block and big block Chevrolet and small block Ford engine to the popular and more dependable serpentine belt design. The modular design, based on the latest CAD/CAM architecture, places all driven components in the tightest possible configuration. Systems are available in a short or long pump style and with or without power steering.



CHEVY LS FRONT RUNNER DRIVE SYSTEM

The LS Front Runner™ features the smallest component package available for easier engine swaps into older vehicles. *LS kits include* • Vintage Air's exclusive machined truss-type mounting bracket • Stewart high performance water pump • power steering pump • SD7 compressor • 140 amp alternator • aluminum pulleys • ATI harmonic balancer • ARP polished stainless bolt kit • Dayco serpentine belt. For all 5.3L, 5.7L, 6.0L, 6.2L and 7.0L GM LS Series engines.

174014	With power steering, bright finish	\$2,950.00
175015	Non power steering, bright finish	\$2,695.00
174011	With power steering, black hard coat	\$2,795.00
175011	Non power steering, black hard coat	\$2,575.00



CHEVY SMALL BLOCK AND BIG BLOCK FRONT RUNNER DRIVE SYSTEMS

The exclusive truss bracket bolts to the block instead of the head or intake manifold solving the problem of various small block Chevy head and intake configurations.

Kits include • machined truss-type mounting bracket • Stewart high performance water pump • power steering

pump and bracket • SD7 compressor with formed hardlines and clutch cover • 140 amp alternator • aluminum pulleys • OEM belt tensioner with cover • ARP polished stainless bolt kit • Dayco serpentine belt • extended heater hose nipple. Note: Not for LT1 engines.

SMALL BLOCK

174015	With power steering, bright finish	\$2,265.00
174008	With power steering, black hard coat	\$2,215.00
175020-SCA	Non power steering, bright finish	\$2,075.00
175010-SCA	Non power steering, black hard coat	\$2,075.00

BIG BLOCK

174058	With power steering, bright finish	\$2,380.00
174048	With power steering, black hard coat	\$2,330.00
175060-BCA	Non power steering, bright finish	\$2,190.00
175050-BCA	Non power steering, black hard coat	\$2,140.00



SMALL BLOCK FORD FRONT RUNNER DRIVE SYSTEM

174100	w/ PS, bright	\$2,640.00
174101	w/ PS, black	\$2,615.00
175103-SFA	w/o PS, bright	\$2,350.00
175102-SFA	w/o PS, black	\$2,375.00

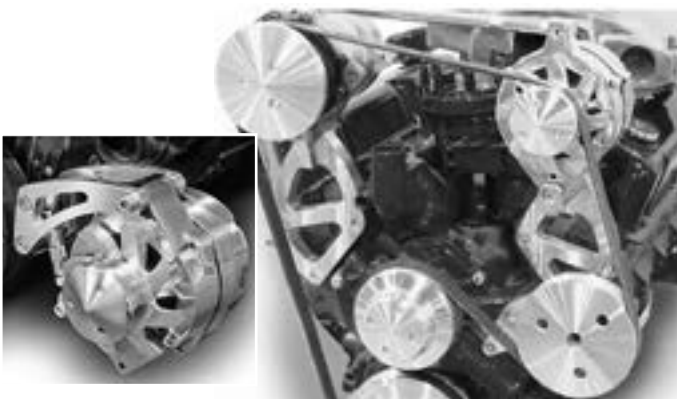

MARCH PERFORMANCE PULLEYS AND BRACKETS

March has a huge selection of complete drive systems, Brackets and pulleys. Way to many to list here. We can set you up with whatever you need so give us a call.

They have kits for: • Chevy Small Block • Chevy Big Block • Chevy LS • Chevy LT1 • Ford Small blocks, Clevalands and Windsors • Ford Flatheads • Buick • Olds • Chrysler Wedge and Hemis





GEN-IV MAGNUM AIR CONDITIONING UNIT

Now you can enjoy true bi-level, infinitely adjustable comfort in your classic car. This large system can handle even the largest sedan or wagon.

GEN-IV™ SYSTEMS include • Evaporator and Mounting Brackets
• Wiring Harness • Electric Solenoid Heater Control Valve • A/C Duct Hoses • Drain Kit • Defrost Kit Includes Hoses and Ducts

Gen IV System features:

- Fully electronic operation, No cables or vacuum controls
- Micro-processor controlled coil temperature monitor. No capillary tube to install!
- Separate high capacity heat and cool coils
- Aluminum plate/fin A/C coil
- Copper/brass Cuprobraze™ parallel flow heater coil
- In full A/C mode air by passes heater core resulting in less restriction and increased airflow.
- Blend air door for instant temperature adjustment
- Infinite dash/floor air blend
- Infinite defrost /floor air blend with dedicated defrost
- Variable speed blower motor
- Positive shut off solenoid operated heater control valve in max A/C
- Multiple control panel options

Dimensions: 26" long, 10.5" deep, 10.5" high

Controls and vents must be purchased separately.

671400-VUZ GEN-IV Magnum - Heat, Cool & Defrost . . . \$850.00



BASIC GEN-IV CONTROL PANELS

Streamline 3 knob panel is available for the Gen-IV Magnum. Features soft white LED lighting through the knobs.

- | | | |
|------------|------------------------------------|----------|
| 491210-RUA | Polished horizontal | \$220.00 |
| 491214-RVA | Polished vertical | \$210.00 |
| 491223-RUA | Black anodized horizontal. | \$230.00 |
| 491226-RVA | Black anodized vertical. | \$230.00 |



GEN II HEATER WITH DEFROST

The ideal system for trucks and smaller hot rods. Servo motor controlled air door and heater coolant control valve. Controls operate temp, fan speed and heat/defrost balance. Order ducts and vents separately. Dimensions: 9.250" long, 5.5" deep, 10" high

- | | | |
|-----------|--|----------|
| 506101 | Heater with defrost | \$229.00 |
| 50616-VUZ | Bi-Level Heater with defrost | \$249.00 |



Super Cooler
61005 Series



Compac 68000 Series

Mini 66005 Series

GEN-II AIR CONDITIONING UNITS

GEN-II Vintage Air units use servo motor control technology. They feature true bi-level operation in cool and heat modes and a more powerful dedicated dehumidified defroster mode.

GEN II™ SYSTEMS include • Evaporator and Mounting Brackets
• Wiring Harness • Electric Solenoid Heater Control Valve
• A/C Duct Hoses • Drain Kit • Defrost Kit Includes Hoses and Ducts

Controls and vents must be purchased separately.

GEN II SUPER COOLER 61005 SERIES

Amazing performance is achieved with the GEN II Super's "D" shaped air outlets. As an added benefit, you can position all 4 louvers wherever you need them. The ideal system for the largest sedans and wagons.

Dimensions: 24" long, 8.5" deep, 8.5" high

- | | | |
|-------------|---|----------|
| 61005-VUX-A | GEN II Super -heat & cool | \$530.00 |
| 61005-VUZ-A | GEN II Super - heat, cool & defrost | \$600.00 |

GEN II COMPAC 68000 SERIES

Excellent performance with three 2-1/2" vents allowing you to position louvers wherever you need them. Ideal for coupes and smaller sedans.

Dimensions: 20.5" long, 7.5" deep, 9" high

- | | | |
|-------------|--|----------|
| 68000-VUX-A | GEN II Compac -heat & cool | \$595.00 |
| 68000-VUZ-A | GEN II Compac - heat, cool & defrost | \$570.00 |

GEN II MINI 66005 SERIES

The ideal system for trucks and smaller hot rods.

Dimensions: 19" long, 7.3" deep, 9" high

- | | | |
|-------------|--|----------|
| 66005-VUX-A | GEN II Mini - heat & cool | \$505.00 |
| 66005-VUZ-A | GEN II Mini - heat, cool & defrost | \$570.00 |



BASIC GEN-II CONTROL PANELS

These are basic control panels for GEN-II units. They offer OEM style operation and work with the electronic servo controls. Plug-in connections. No vacuum lines or cables. Cool soft internal lighting.

- | | | |
|-----------|--|---------|
| 49110-SHQ | 4-Lever fingertip horizontal panel | \$75.00 |
| 49110-SVQ | 4-Lever fingertip vertical panel | \$75.00 |
| 49200-RHA | 4-Knob horizontal, black. | \$60.00 |

Call 402.886.2275 or click: www.heinzmanstreetrods.com



SureFit kits are available for:

- 1955-57 Chevrolets
- 1958-67 Corvettes
- 1968-76 Corvettes
- 1967-78 Camaros/Firebirds
- 1964-69 Chevelle/El Camino
- 1964-67 GTO
- 1966-69 Nova
- 1959-64 Chevy
- 1964-70 Mustang
- 1970-74 Barracuda/Challenger
- 1966-77 Bronco
- 1953-56 Ford F-100
- 1947-55 Chevy/GMC trucks
- 1955-86 Chevy trucks

VINTAGE AIR GEN IV SUREFIT SYSTEMS

Vintage Air Gen IV SureFit air conditioning, heating and defrost kits retrofit popular 50s, 60s and 70s cars and trucks with modern climate control systems. The Gen IV systems feature all electronic controls requiring no cables, capillary tube or vacuum connections. They are truly "fly-by-wire". These Gen IV systems use separate heating and cooling coils for superior performance. The internal air control doors are servo operated to provide infinite dash, floor and defrost blending. SureFit kits are designed to install with minimal drilling and no fabrication required. Some kits include replacement control panels or modifications to existing controls.

Most complete kits include • Air conditioning, heating and defrost combination designed specifically for your vehicle complete with all mounting brackets, hardware, louvers, duct hose, controls, wiring harness and installation instructions. • SuperFlow™ condenser, mounting brackets • standard drier • safety switch • pre-formed aluminum lines • firewall cover plate • all mounting hardware.

Evaporator kits are also available that includes only what is required under the dash • Air conditioning, heating and defrost combination designed specifically for your vehicle complete with all mounting brackets, hardware, louvers, duct hose, controls, wiring harness and installation instructions, all mounting hardware.

NOTE: Some installations may require additional engine pulleys not included with kits. You must provide pulleys, v-belts and refrigerant.

Most complete kits \$1,800.00
Most evaporator kits \$850.00



GEN-II UPGRADE CONTROL PANELS

These are basic control panels for GEN-II units. They offer OEM style operation and work with the electronic servo controls. Plug-in connections. No vacuum lines or cables. Cool soft internal lighting.

- 49110-SHQ 4-Lever machined horizontal panel \$75.00
- 49110-SVQ 4-Lever machined vertical Panel \$75.00
- 491200-RUA 4-Knob horizontal, polished aluminum ... \$175.00
- 491229 4-Knob horizontal, black aluminum. \$175.00
- 48104-RUQ 3-Knob w/lever oval, polished aluminum . \$175.00
- 481005 3-Knob w/lever oval, black aluminum. . . \$175.00

DASH LOUVERS

In-dash and under-dash louvers.

- 49051 Rectangular kick Panel \$18.00
- 49054-VUL Round under-dash \$18.00
- 49050-VUL Rectangular under-dash \$18.00
- 49215 Round Slider series- machined aluminum .. \$105.00
- 491902 Oval aluminum. \$99.00
- 49062-VUQ Streamline- polished aluminum trim \$55.00
- 49053-VUQ Round- billet aluminum \$28.00

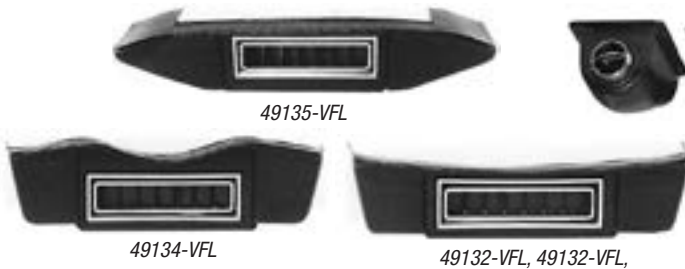

UNDER-DASH LOUVER PODS

Use these black plastic pods to easily mount louvers to the bottom of the dash panel. Control knobs can also be inserted in the face. With chrome trim louver.

49132-VFL	1928-32 Ford underdash	\$20.00
49137-VFL	1937 Ford, 1930-35 Chevy underdash . . .	\$20.00
49134-VFL	1933-34 Ford underdash	\$20.00
49135-VFL	1935-36 Ford underdash	\$20.00
492000-VUA	Univ. flat underdash- 32" long, 2 piece . .	\$69.95
49100-VFL	Universal flat underdash	\$20.00



134a BARRIER TYPE REFRIGERANT HOSE KIT

Use barrier type refrigerant line for use with HFC-134a and R-12 refrigerants. Includes adequate hose length to connect complete system, all O-ring fittings, fittings with service ports and crimp ferrules. Includes: 6 ft. of #6, 4 ft. of #8, 5 ft. of #10 barrier hose. Standard or extra length kits available.

- 31700-VBD Beadlock fitting hose kit with black drier. \$138.00
- 31703-VBD Beadlock fitting hose kit w/o drier \$129.00

STANDARD HEATER HOSE KITS

Includes: 10 feet of 5/8" heater hose, 2 standard male O-ring 90 degree or straight bulkhead fittings, 2 female O-ring 90 degree fittings and 8 hose clamps.

- 31400-VUD 90° bulkhead fitting heater hose kit \$49.00
- 31401-VUD Straight bulkhead fitting heater hose kit . . \$49.00



A/C AND HEATER FITTINGS

We have a large selection of barbed and beadlock O-ring fittings for heating and A/C in #6, #8 and #10 sizes.

Call with your requirements each \$7.00



A/C AND HEATER BULKHEAD FITTINGS

An easy way to run the A/C and heater lines thru the firewall. Just drill four individual holes. Gives a weather tight seal and professional look to your installation. Accepts O-ring fittings.

FOUR WAY SQUARE- 3.0 X 3.0"

384600-MBA	A/C-heater (#6-10 male) polished alum. . .	\$65.00
384800-MBA	A/C-heater (#8-10 male) polished alum. . .	\$65.00
389600	A/C-heater (6-10 male) black anodized . . .	\$69.00
389800	A/C-heater (8-10 male) black anodized . . .	\$69.00

FOUR WAY IN-LINE- 1.25 X 5.75"

386600-MBA	A/C-heater (#6-10 male) polished alum. . .	\$65.00
389804	A/C-heater (#6-10 male) black anodized . .	\$69.00

TWO WAY- 1.25 X 2.75"

382600-MBA	A/C (#6-10 male) polished alum	\$45.00
382800-MBA	A/C (#8-10 male) polished alum	\$45.00
382680-MBA	A/C (#6-8 male) polished alum	\$45.00
382000-MBA	heater (10-10 male) polished alum.	\$41.00
389602 2-way	A/C (#6-10 male) black anodized	\$44.00
389802 2-way	A/C (#8-10 male) black anodized	\$44.00
389603 2-way	A/C (#6-8 male) black anodized.	\$44.00
389803 2-way	heater (#10-10 male) black anodized . . .	\$44.00



CHROME DRIER

Features a built in mounting bracket and compact size. 2.5" x 6"

- 07310-VUQ Chrome drier with bracket \$69.00
- 01311-VUQ Replacement chrome canister \$39.00
- 07308-VUQ Chrome drier w/binary switch \$75.00
- 07309-VUQ Chrome drier w/trinary switch. \$94.00

TRINARY SWITCH KIT

Low pressure and high pressure compressor clutch cut off functions PLUS electric fan engagement signal at 254 psi. 30 psi low pressure cut off. 406 psi high pressure cut off. Recommended for all electric fan installations.

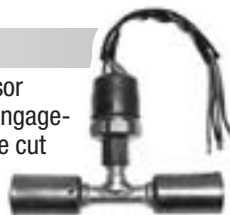

- 24676-VUS Trinary switch kit for barb crimp \$51.00
- 24678-VUS Trinary switch kit for beadlock crimp. \$51.00
- 11076-VUS Male thread trinary switch only \$35.50

Call 402.886.2275 or click: www.heinzmanstreetrods.com

Air Conditioning and Heating Parts



SANDEN SD-508 A/C COMPRESSOR

This compressor is recommended for any Vintage Air system. It pumps 8.4 cubic inches per revolution with a maximum 6000 sustained RPM range. Available in standard finish or polished. Available for V-groove, 7 or 8-rib serpentine or 3/4" single belt.

- 04808-VUA** Double V groove pulley-standard finish \$199.00
- 04808-VUQ** Double V groove pulley-polished finish \$249.00
- 048085** Double V groove pulley-chrome finish. \$309.00
- 04808-VMA** 7- Groove serpentine pulley-standard finish . . . \$199.00
- 04808-VMQ** 7- Groove serpentine pulley-polished finish . . . \$249.00



03332-VUC

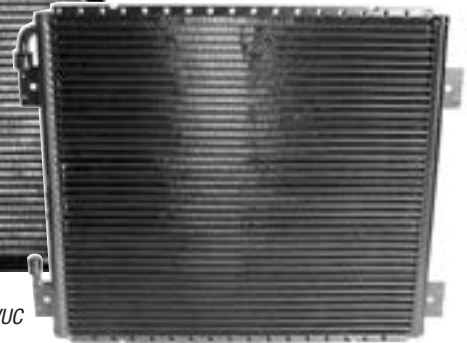

03769-VUC

VINTAGE AIR SUPERFLOW™ CONDENSERS

These condensers are designed for street rods, fifties cars and trucks and most late model cars. They are sized to fit in tight spots and still deliver big condenser performance! Vintage Air Designed SuperFlow™ Micro Tube condensers provide increased refrigerant contact with the micro tube walls and multiple passes per circuit. The low restriction pathway has up to 40% more capacity than a comparably sized tube and fin condenser. All condensers include a universal mounting bracket kit. Male O-ring fittings- #8 fitting at top and #6 at bottom.

VERTICAL SUPERFLOW™ CONDENSER

- 03332-VUC** 1932 Ford condenser, 20.75 H x 14 W x .75" \$139.00
- 03032-OFV** 1932 Ford condenser kit- includes condenser, hardlines, brackets. . . . \$165.00
- 03769-VUC** 1939-40 Ford, 55-57 Chevy condenser 17 H x 19 W x .75" \$149.00
- 03040-VFC** 1939-40 Ford, 55-57 Chevy condenser kit- includes condenser, hardlines, dryer \$179.00

HORIZONTAL SUPERFLOW™ CONDENSER

- 03701-OVA** 12 H x 20 W x .83" Thick w/brackets. . . . \$117.00
- 03704-OVA** 12 H x 24 W x .83" Thick w/brackets. . . . \$149.00
- 03260-VUC** 14 H x 18 W x .83" Thick w/brackets. . . . \$139.00
- 03261-VUC** 14 H x 20 W x .83" Thick w/brackets. . . . \$139.00
- 03262-VUC** 14 H x 22 W x .83" Thick w/brackets \$149.00
- 03263-VUC** 14 H x 24 W x .83" Thick w/brackets. . . . \$149.00
- 03770-VUC** 14 H x 25.5 W x .83" Thick w/o brackets. . \$139.00
- 037030-OVR** 16 H x 28.5 W x 1.0" Thick w/brackets . . \$179.00



35136-VUG



35135-VUG

A/C COMPRESSOR HARDLINES

These pre-bent lines give you compact and professional line routing. Designed for Vintage Air brackets, but may work with others.

- 35135-VUG-A** for pre-'35 cars, 134a, polished \$69.00
- 35136-VUG-A** for '35-up cars, 134a, polished \$69.00

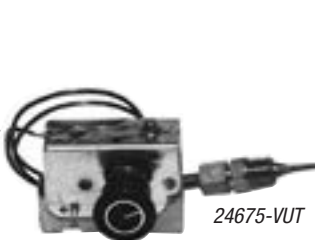

24675-VUT

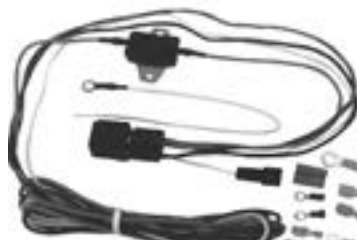

44505-VUJ

ADJUSTABLE FAN THERMOSTAT

Automatic fan control at your desired temperature setting (180-240 degrees). Probe installs into radiator drain with included pos-a-seal fitting. Use separately or with A/C trinary function safety switch. Fan wiring kit recommended.

- 24675-VUT** Adjustable thermostat \$39.95
- 23101-VUW** Thermostat wiring kit \$35.00

HEAVY DUTY ELECTRIC FAN WIRING KIT

This fan wiring kit is recommended for all electric fan installations. Allows direct current to fan without placing load on your fan switch. Prevents current feedback when fan is not engaged.

- 23102-VUW H.D. wiring kit** \$69.95

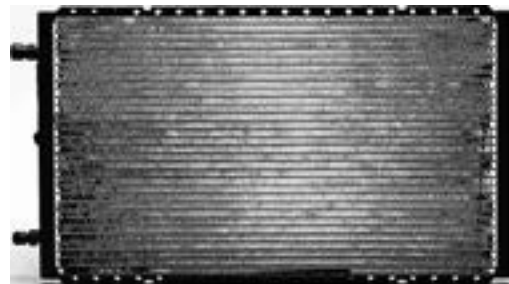

03701-OVA

Air Conditioning System Parts



POWERMASTER ALTERNATORS

Show chrome plated rebuilt GM alternators with internal regulator, heavy duty diodes and oversized bearings, chrome fan and v-belt pulley, proof of performance tag and gold battery post for better conductivity. 140 amp is recommended for EFI, A/C and electric fans.

17294	GM 100 amp (7" case)	\$149.99
378021	GM 140 amp (7" case)	\$229.99
8-37100	Ford 100 amp polished one-wire	\$194.99

THE DETAIL ZONE -FUEL INJECTION WIRING

This system uses a junction panel as a link between the engine sensors and factory computer. The Telorvek panel allows the adjustment of wire lengths to create an exceptionally neat installation along with the advantages of superior troubleshooting plus you can mount the computer anywhere inside the vehicle.



Detail Zone fuel Injection systems include necessary connectors for that particular application, including single or dual fans when required. These systems are complete and operate the engine in closed loop, which allows the engine to RUN LIKE FACTORY. Diagnostic Scan Tool connections and Malfunction Indicator Lamp Circuits (MIL) are supplied for each application, allowing the system to be scanned at any OEM dealer or repair facility.

Typically no special prom changes, computer reprogramming or trick parts are necessary. Everything is available from your local dealership. Kits include new GM or Ford connectors with crosslink, fire resistant wire printed every 10 inches with the sensor and terminal it connects to. The kits come with 20 feet of wire for each sensor that is simply trimmed to length, terminals installed and connected to the Telorvek panel. Some panel models contain fuel pump and cooling fan relays in the panel cover as required.

Kits are available for GM TPI, GM LT1, GM Ram Jet, Buick Turbo V6, GM Northstar/Aurora, Ford 5.0, Ford 4.6, 5.8, 7.5 3.8 V6 priced from \$385.00



GM-65 GM Small 95 Ford

STREET & PERFORMANCE ALTERNATORS

Street & Performance alternators are rebuilt in-house to the same standards as all S&P products. All are available, natural, polished and chrome. Prices below are for chrome. All are sold w/o fans and pulleys. Small late model GM are available clocked 10, 12 and 2.

GM 65 Amp internal regulated	\$134.95
100 Amp internal regulated.	\$161.95
GM Small 95/105 Amp internal regulated (core charge).	\$226.95
Ford New Style 90 Amp internal reg (Internal Fan)	\$367.95

RON FRANCIS COMPONENT PANEL WIRING KITS

RON FRANCIS BARE BONZ BASIC WIRING KITS

The Bare Bonz kit has everything you need for a basic electrical system. This kit has 8 fuses and 10 circuits and plenty of wire to take care of your basic engine, dash and lighting, gauges and some accessories yet will still work with electronic fuel injection. Only 7-1/2" L x 3-1/8" W x 2-7/8" H.



BB-99 BARE BONZ wiring kit GM engines	\$415.00
BB-78 BARE BONZ wiring kit Ford engines	\$415.00
BB-68 BARE BONZ wiring kit Mopar engines	\$415.00

RON FRANCIS EXPRESS WIRING KITS

These kits are designed for each application. Wiring is included for the complete car, including starter, alternator, most stock GM, ididit, Flaming River and other brands of steering columns. It will wire full gauge sets including tach; address HEI, points and after-market distributors, neutral safety switches, most safety inspections including high and low beams, indicator lights, parking, turn signal, brake and third brake light. The panel readily accepts fuel injection. A multi-connection battery junction block reduces the number of wires going to the starter. Kits use high temperature fire resistant, color-coded wire with the circuit clearly printed on each wire. Kits also include a headlight switch with wiring, a isolated cooling fan relay and color coded instructions.

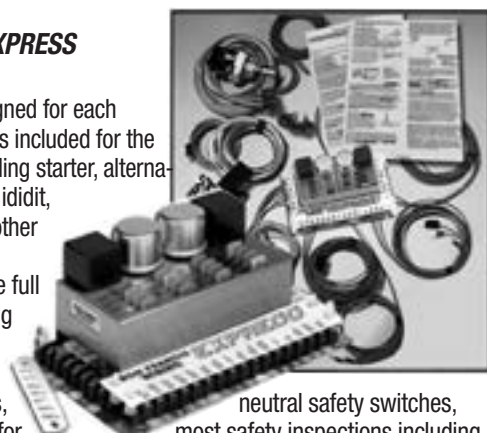

XP-66 EXPRESS wiring kit GM engines	\$525.00
XP-67 EXPRESS wiring kit Ford engines	\$525.00
XP-68 EXPRESS wiring kit Mopar engines	\$525.00

Wiring and Electrical Components

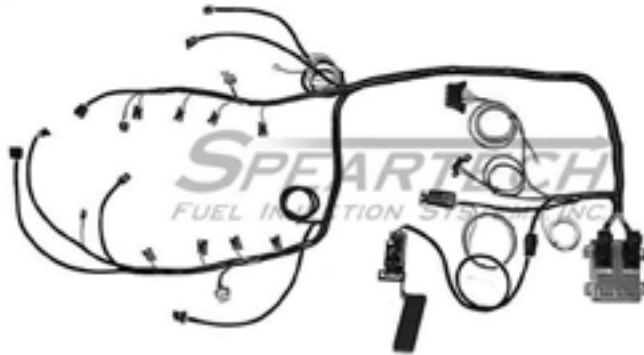

SPEARTECH EFI WIRING HARNESSES

Speartech offers custom stand alone wiring harness packages for all of the popular LS engines. Cable throttle, drive by wire, 4L60E, 4L80E, T56, whatever your combo, Speartech has you covered!

Speartech uses O.E.M. style Packard® terminals, connectors and wire in a smooth flowing, attractive layout. Harnesses are covered in black split loom tubing for a clean look.

Harnesses are built as full function, closed loop systems without the add-on emissions equipment. Custom harness lengths are available for your convenience. All harnesses include a fuse block to protect the engine/transmission circuits, a PCM controlled fuel pump relay, control wires for the cooling fan relay, and an OBD-2 diagnostic port/check engine light combo for future diagnostic troubleshooting should there ever be a problem. All harnesses are manufactured using OEM style Packard® XLP wire and connectors and feature a check engine light, diagnostic connector, fuel pump relay, and EASY hookup. All harness are test run on an engine before shipping.

- TPI with 700R4 or T5** includes ECM and custom chip. . . . \$750.00
- LT1 with 4L60E or T56** (94-97 style)..... \$650.00
- 4.8, 5.3, 6.0 with 4L60E or 4L80E** \$750.00
- LS1/LS6 with 4L60E or T56** \$750.00
- LS1/LS6, 4.8, 5.3, 6.0 ETC** with electronic throttle control, includes pedal-to-module harness..... \$800.00
- Vortec 8100 with 4L80E**..... \$900.00
- LS2, LS3, LS7, LS9 and related truck engines (2006-present)** Includes custom-length wiring harness, fully programmed ECM, electronic throttle pedal and throttle pedal harness.

- Manual transmission harness package**.....\$1,595.00
- Automatic transmission harness package** includes transmission control module \$1,898.00



510625

AMERICAN AUTOWIRE WIRING HARNESSES

American Autowire Wiring Harnesses are OEM quality made in the USA and use only the highest quality wire, terminals and components. Harness wires are labeled and use ATO style fuse panels. All kits include color wiring diagrams and complete instructions/

- 510008 Power Plus 20 Kit**, factory style pre-wired fuse box. 20 circuits, includes headlights and dimmer switch \$399.00
- 510625 Route 9 Universal Wiring System**, factory style pre-wired compact fuse box. 9 basic circuits for roadsters, rat rods. . \$329.00



510625

- 510006 Builder 19 Wiring System**, sealed ATO style fuse box. Harness is laid out for almost all aftermarket accessories like gauge packages, power windows, Heating/AC, electric fans, etc.. \$569.00
- 500695 Highway 22 Wiring Kit**, Our most versitle and powerful system. 22 curcuit Fuse panel can be mounted anywhere and is protected by a 175 amp Mega-Fuse. GLX labeled wire, dedicated EFI , all aftermarket accessories like gauge packages, power windows, heating/AC, electric fans, etc..... \$619.00

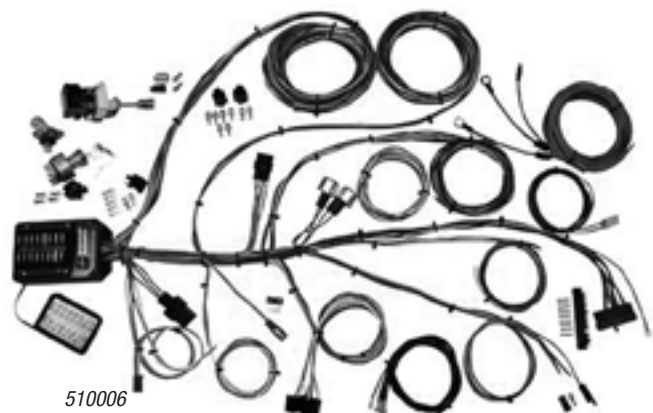

510006

EFI Wiring Harnesses



AUTOMETER GAUGE KITS

STREET ROD SERIES with vintage style dome lens

These gauge sets use "around-the-dial" lighting with either red or green tinted bulbs. Includes 3-1/8" electronic or mechanical speedometer and 2-1/16" oil pressure, water temperature, voltmeter, & fuel gauges. All necessary sending units are included. Fuel sender may not work with all stock fuel tanks. Electronic speedometer sender sold separately.

- 1300 Arctic White mechanical speedometer, chrome bezels, white face, red needles **\$395.00**
- 1302 Arctic White electronic speedometer, chrome bezels, white face, red needles **\$505.99**
- 1808 Antique Beige mechanical speedometer, chrome bezels, light tan face, red needles **\$395.00**
- 1809 Antique Beige electronic speedometer, chrome bezels, light tan face, red needles **\$505.00**
- Matching Tach. **\$179.95**
- 5291 Hall Effect Speedometer Sender Most GM/Chry. . . **\$94.95**
- 5292 Hall Effect Speedometer Sender Ford Plug-in . . . **\$94.95**



STREET ROD SERIES with vintage style dome lens (cont)

- 1601 Old Tyme White mechanical speedometer, chrome bezels, tan face, black needles **\$381.00**
- 1602 Old Tyme White electronic speedometer, gold bezels, tan face, black needles **\$499.00**



STREET ROD FIVE INCH QUAD SERIES

- 1303 Arctic White electronic quad/speed set, 5" . . . **\$525.99**
- 1399 Arctic White tachometer, 5" **\$195.00**
- 1403 Designer Black electronic quad/speed set, 5" . **\$525.99**
- 1499 Designer Black tachometer, 5" **\$189.00**

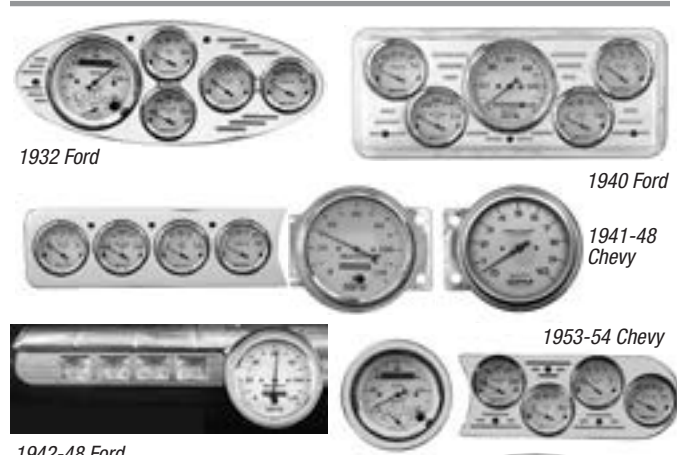

BOESE GAUGE PANELS

Machined aluminum panel. Gauges and factory chrome trim not included.

1955-56 Chevy



- 1932-40 Ford **\$124.95**
- 1942-48 Ford gauge panel **\$89.95**
- 1942-48 Ford speedometer, 5" trim ring **\$89.95**
- 1934-50, 1953-55 Ford pick-up **\$124.95**
- 1951-52 Ford pick-up **\$99.95**
- 1936 Chevy for 3-3/8" quads **\$124.95**
- 1937-39 Chevy **\$99.95**
- 1937-38 Chevy glove box **\$99.95**
- 1940 Chevy **\$145.95**
- 1941-48 Chevy 4 gauge panel. **\$85.95**
- 1941-48 Chevy 5" speedometer insert. **\$99.95**
- 1941-48 Chevy 5" tach insert **\$99.95**
- 1947-53 Chevy pickup 5" quads. **\$99.95**
- 1951-52 Chevy 5" quads. **\$124.95**
- 1953-54 Chevy **\$124.95**
- 1955-56 Chevy, for 3-3/8" quads **\$124.95**
- 1957 Chevy **\$139.95**

Gauges and Dash Panels

Gauges, Dash Panels, Power Windows



Velocity Series
VS01WBLF

Hot Rod Series
HR01SLF



Vintage Series
VT02SLC



All-American Series
AN51SLC

CLASSIC INSTRUMENTS GAUGE SETS

Classic Industries uses the latest in technology for smooth action, reliability, accuracy and good looks. Choose from a variety of face styles, colors, sizes, and sweeps to match your car's style. Includes 3-3/8" electronic speedometers and tachometers and 2-1/8" oil pressure, water temperature, voltmeter, & fuel gauges. All necessary sending units are included.

- HR01SLF Hot Rod Series**, chrome bezels, black face, white pointers **\$607.00**
- VS01WBLF Velocity Series**, black bezels, black or white face, orange needles..... **\$628.00**
- VT02SL Vintage Series**, polished bezels, cream face, red needles..... **\$481.00**
- AN51SLC All-American Nickel Series**, polished nickel bezels, nickel face, red needles, 5" speedo/tach, 2" . **\$913.00**

Many sizes, colors and colors of each series available.

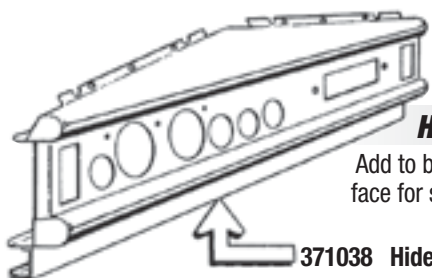

HIDE-A-SWITCH PANEL

Add to bottom of dash with 2" or 3" face for switch or other accessories. 47" and 60" for wider cars.

371038 Hide-a-switch **\$65.00**



POWER WINDOW SWITCH RELAY

If you want to use your original power window switches with these conversion kits, the polarity of the switches must be reversed. These Nu-Relic relays make it easy.

PW relay **\$35.00**



1934 Ford
Front Window



1949-51 Ford Front Window



Nostalgic
Switches

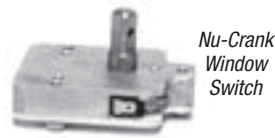

Nu-Crank
Window
Switch

NU-RELICS POWER WINDOW KITS

These kits are car specific and bolt to the original mounting holes and use the stock channels • Many have the option to remove the vent window • New American made Delco OEM Motors • Made of 1018 cold roll steel • Brass oilite thrust bearings at pivots • Gear plate teeth are hardened with cryogenics for longer life • Kits include standard chrome or black switches/wire harness and conduit • Nostalgic or Nu-Crank switches available • Lifetime warranty

Model A, 1932 Ford Coupes and Sedans, 1933-34 Ford Coupes and Sedans, 1936-40 Ford Coupe, Sedan and Convert., 1941-48 Ford Coupe and Sedan, 1949-66 Ford HTs and Converts. 1964-70 Mustang, 1928-79 Ford Trucks, 1930-48 Chevy Coupes & Sedans, 1949-57 Chevy HTs, Sedans, Convertibles, 1958-76 Impala, Camaro, Chevelle, Nova, 1936-87 Chevy Trucks

Also available for Corvettes, T-Birds, Mopar, Studebakers

Most two door window conversions start at..... \$495.00

Most four door window conversions start at..... \$895.00

Specify chrome or black switches

Nostalgic chrome switches- 2 window w/harness..... \$225.00

Nu-crank switches- pair, add \$30 for harness..... \$178.00

SPECIALTY POWER WINDOWS

Specialty Power Window conversions include full printed and video instructions, hardware, and necessary templates, as well as GM switches and a full wiring harness. We use only brand new GM cable drive motors, switches and components.

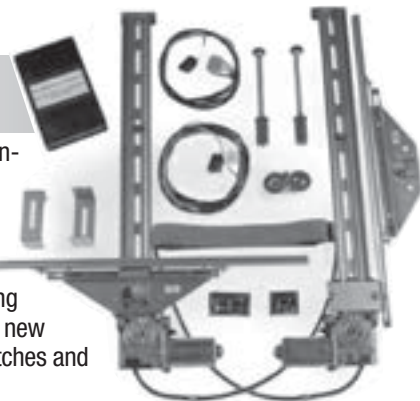

Tall T & Model A two door conversions start at..... \$475.00

Street rod/universal two door conversions start at.... \$475.00

Most four door window conversions start at..... \$895.00

1955-57 Chevy HT 4 window Conversions..... \$895.00

1955-57 Chevy two door conversions..... \$475.00

1967-69 Camaro coupe 4 window conversions..... \$895.00

1964-72 Mid-size GM HT 4 window conversions..... \$895.00



SPECIALTY POWER WIPER KITS

Specialty Power Windows universal Dual-Wiper Drive Kit has two wiper shafts that will accept 1/2 inch fine spline knurl or 1/4 inch wiper arms . The output shafts are cable driven by a remote mounted commercial duty 300 in. lbs. stall torque 2 speed wiper motor. The sweep is adjustable from 90 degrees to 160 degrees in 10 degree increments. Kits are available with an adjustable delay 2-speed intermittent self park switch with or a 2-speed self park switch (rotary knob or black rocker). These dual wiper kits are best suited for cars under construction. Motors can be mounted in kick panels or under dash. Wipers can be over or below windshield Some applications will require modifications to the original holes. All universal kits come with written and video instructions. (Kits Do Not Include Arms and Blades) Standard kits come with a 72" drive cable. A 144" Drive Cable and Tubing is optional.

- Universal wiper kit w/2 spd rotary or rocker switch, 72" . . . \$289.00**
- Universal wiper kit w/2 spd intermittent switch, 72" \$314.00**
- Universal wiper kit w/2 spd rotary or rocker switch, 144" .. \$290.00**
- Universal wiper kit w/2 spd intermittent switch, 144" \$324.00**
- 1947-59 Chevy PU w/2 spd rotary or rocker switch \$325.00**
- 1947-59 Chevy PU w/2 spd intermittent switch \$359.00**
- 1955-57 Chevy cars w/2 spd rotary or rocker switch \$350.00**
- 1955-57 Chevy cars w/2 spd intermittent switch \$384.00**

Most kits are also available without wiring or switches

ELECTRIC WIPER MOTORS

Brackets are designed to bolt-in and work with original linkage. Includes bracket, 12V motor, two-speed switch, wiring. Does not work with factory radio.

- A-17508HD12 1940 Ford electric wiper kit \$269.95**
- 11A-17508 1941-42 Ford electric wiper kit \$269.95**
- 51A-17508 1946-48 Ford electric wiper kit \$269.95**
- 1937-40 Chevy electric wiper kit. \$269.95**
- 1941-48 Chevy electric wiper kit. \$269.95**
- 1947-53 Chevy PU electric wiper kit . . . \$269.95**

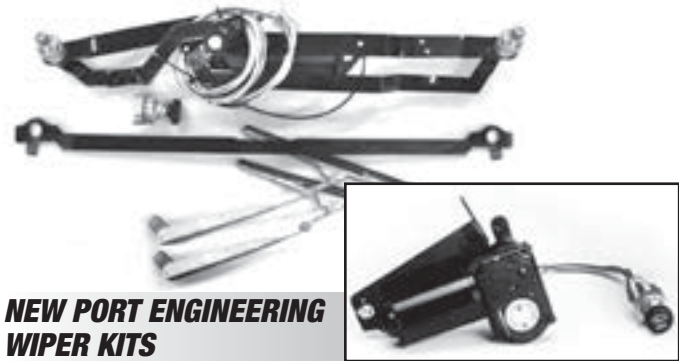

NEW PORT ENGINEERING WIPER KITS

New Port Engineering **Clean Wipe Wiper Drive kits** are designed to work with the original wiper linkage and brackets. They are not universal kits. Each is designed for a specific car or truck and include a two speed switch and nylon bushings for the linkage arms.

The **Clean Sweep Wiper Systems** include a complete bracket and linkage assembly to replace the original parts. These kits include everything you need, heavy duty 2-speed motor, all mounting brackets, bronze oilite bushed transmissions, linkage, wiring harness, switch, and polished stainless steel wiper arms and blades. It also includes a drill jig to perfectly locate both holes in your header. 3 year warranty.

- 1926-27 Ford T Coupe & Sedan, Clean Sweep System . . . \$459.00**
- 1928-29 Ford A Coupe & Sedan, Clean Sweep System . . . \$459.00**
- 1930-31 Ford A Coupe & Sedan, Clean Sweep System . . . \$459.00**
- 1932 Ford 3-W Coupe & Sedan, Clean Sweep System . . . \$459.00**
- 1935-38 Ford Coupe & Sedan, Clean Sweep System. . . . \$459.00**
- 1937-39 Ford Cabriolet, Convertible, Woody \$269.95**
- 1939-48, 49-61 Ford Coupe & Sedan \$269.95**
- 1928-31 Ford Pickup, Clean Sweep System. \$389.00**
- 1932-34 Ford Pickup, Clean Sweep System. \$459.00**
- 1940-47 Ford Pickup, Clean Sweep System. \$459.00**
- 1948-60 Ford Pickup \$269.95**
- 1935-66 Chevy \$269.95**
- 1962-67 Chevy Nova \$269.95**
- 1967-69 Chevy Camaro \$269.95**
- 1968-72 Chevy Chevelle \$269.95**
- 1939-46 Chevy Pickup, Clean Sweep System \$459.00**
- 1947-72 Chevy/GMC Pickup \$259.95**

Some kits may require an extension for the included switch shaft to use in the stock switch location. Available separately.

UNIVERSAL ELECTRIC WIPER MOTORS

Universal electric wiper motor and arm. Works well on 1939 and earlier Ford coupes and sedans.

- A-17508-E12 \$65.00**



Power Windows and Wipers



Sport Split Back Bench



Split Back Bench



Bench Seat



Universal Bucket Seat

REPRODUCTION SEATS FROM GLIDE ENGINEERING

- All steel construction • On some models, the seat bottom lifts with gas spring support • Back flips forward • Non-sag springs • Lumbar support
- Powder coated finish • Ready to upholster • Seat back reclines
- Frames available for chopped top cars. **Most seats include brackets and sliders or bolt to factory risers, side skirts where needed**
- OPTIONS: Contoured foam, Fold down center arm rest, Tapered seat backs, Vinyl or leather seat covers available for most seats

BENCH SEAT

10-20-50-60	1928-34 Ford	\$782.00
	1928-34 Foam Kit	\$220.00
S-30	1928-34 Ford Seat Sliders	\$120.00

PICK-UP BENCH SEATS

7032	1932 Ford bolts to factory Riser	\$782.00
8034	1933-34 Ford bolts to factory Riser	\$782.00
9036	1935-36 Ford bolts to factory Riser	\$842.00
9141	1937-47 Ford bolts to factory Riser	\$842.00
9248	1948-52 Ford Split Back Rest, w/sliders...	\$966.00
9356	1953-56 Ford Split Back Rest.....	\$966.00
9254	1947-54 Chevy Split Back Rest	\$966.00
9459	1955-66 Chevy Split Back Rest	\$998.00
	Foam Kits For Pick-Ups	\$195-225.00

SPLIT BACK REST BENCH SEATS

SP-50	1931-34 Ford with arm rest w/o sliders...	\$850.00
SP-39	1935-40 Ford with arm rest, side skirts...	\$995.00
SP-47	1941-48 Ford with arm rest, side skirts...	\$995.00
	Foam Kit.....	\$275.00
SP-56	1955-56 Chevy, front, coupe, sedan.....	\$995.00
SP-57	1957 Chevy, front, coupe, sedan, convert..	\$995.00
	Chevy Foam Kit	\$300.00

SPORT BENCH SEAT with split tapered back and arm rest will also fit Chevys and other makes

SP-41	1935-40 Ford	\$995.00
F-41	1935-40 Ford foam kit	\$285.00
SP-42	1941-48 Ford	\$995.00
SP-42	1942-48 Ford foam kit	\$300.00

SPORT BENCH SEAT with low or high bolstered bottom. Includes: frame, foam and sliders

SS-2	Sport bucket seats, high bolsterpair	\$995.00
SS-3	Sport bucket seats, low bolsterpair	\$995.00
HR	Head restspair	\$260.00
	Vinyl cover kits (most seats) start at	\$840.00
	Leather cover kits (most seats) start at.		\$1180.00



Rally-shown in black vinyl



Elite Lumbar shown in grey velour



Pro-90 in black vinyl

PROCAR SEATS BY SCAT

PROCAR has seats to fit almost any hot rod, custom, muscle car or truck and designed to be safe, comfortable and supportive. Most are available in a number of different colors and materials. Bolt-in brackets are available for many applications.

1000 series Rally full reclining seat back for comfort adjustment, adjustable locking headrest. **\$383.00**

1100 series Elite Lumbar support with side bolstering, full reclining and tilting seat back and adjustable headrest for comfort **\$340.00**

1400 series Pro 90 Lowback lever style reclining and tilting seat back. Includes seat sliders **\$264.00**



CUSTOM AUTOSOUND SECRET AUDIO SYSTEM

Secret audio SST is a hidden audio system that offers great flexibility for mounting in any type of vehicle. The main receiver/amplifier unit is usually hidden under the seat, or behind the dash. A 10 ft. cord from the Tuner/Amp plugs into a LCD display. The system can be operated from up to 40 feet away with the included RF (radio frequency remote.)

The small 1" deep LCD display can be mounted flush to the dash or console with the included bezel. The LCD also comes with a bracket for mounting in the glove box, under the dash, in the ashtray, sun visor, console, or wherever you choose. When your installation is finished you'll be rewarded with a quality professionally installed look. **\$279.99**

Seats and Stereo



UNDERCOVER II SPEAKER ENCLOSURES

These Custom Autosound speakers designed specifically for 'under seat' installations. UNDERCOVER II has an 8" woofer and 2 Piezo tweeters in each box and gives you a much fuller deeper sound. Measure 11"W x 12.5"D x 3"H

Undercover II . . . pair \$139.99

KICK PANEL SPEAKERS

Custom Autosound's new kick panel speaker assemblies sound great, enhance interior appearance and don't require cutting your door. Most models feature 6½" coaxial (2-way) speakers with 80 watt power handling capacity

Kick panels are available for '39-40 Ford Coupe and Convert, '40-46 Ford Pickup, '47-72 Chevy-GMC Pickups '64-68 Mustangs, '67-68 Camaros, '55-57 Chevy and GM muscle Cars

Kick panels \$129.00



POWER ANTENNA

Small compact design requires only 11-1/4" of vertical clearance. Semi-automatic AM/FM.

XMQ-1 \$59.95



AMPLIFIED ELECTRONIC AM/FM ANTENNA

Designed for optimum AM/FM reception. Excellent solution for street rods or any vehicle where a conventional antenna is not desirable. No drilling or grounding required. Requires 12-volt power. 104" Power and Antenna Cable

ANTUV- \$34.95



TWIN HORNS

Replacement horns, loud but small in size. Chrome caps and grills protect and beautify. Ideal for street rods.

AH-401 Twin Horns . . . \$34.95

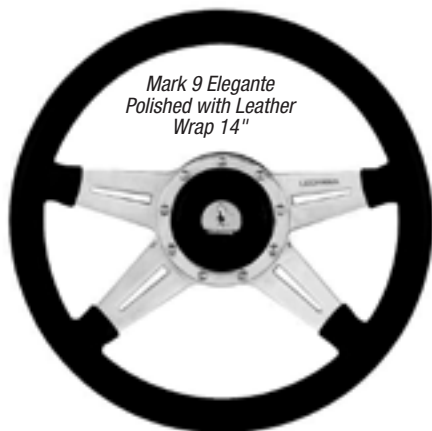

Mark 9 Elegante Polished with Leather Wrap 14"

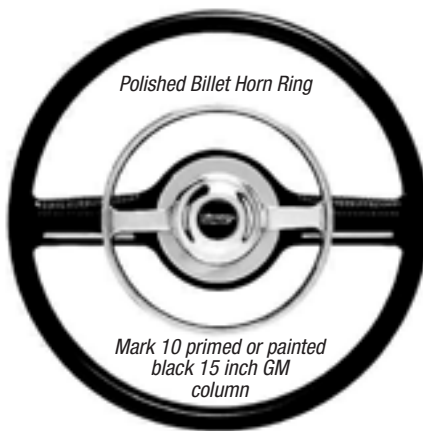

Polished Billet Horn Ring

Mark 10 primed or painted black 15 inch GM column



Newstalgic Banjo Stainless Steel Center with Leather Wrap 14.5"



Mark GT Elegante, black with Leather wrap 14"



Mark 4 Supreme Polished with Leather 14 inch



Mark 40 Available primed or painted black 15 inch GM column

LECARRA STEERING WHEELS

Lecarra wheels are machined from 6061 T-6 aluminum in one piece. Most have a 1.5" dish. Leather available in dark brown, black, cream, carmel, corvette red, light gray.

- Mark 4 GT, \$213.95
- Mark 4 Supreme, \$213.95
- Newstalgic Banjo \$465.00
- Mark 40 \$299.00

- Mark 9 Elegante \$213.00
- Mark 10 \$275.00
- Hub adapter, Specify center emblem \$49.00
- Polished hub \$79.00
- Aluminum horn button \$43.00
- V-8 horn button \$85.00



Stereo and steering wheels

Call 402.886.2275 or click: www.heinzmanstreetrods.com

Steering Columns, U-Joints and Shafts

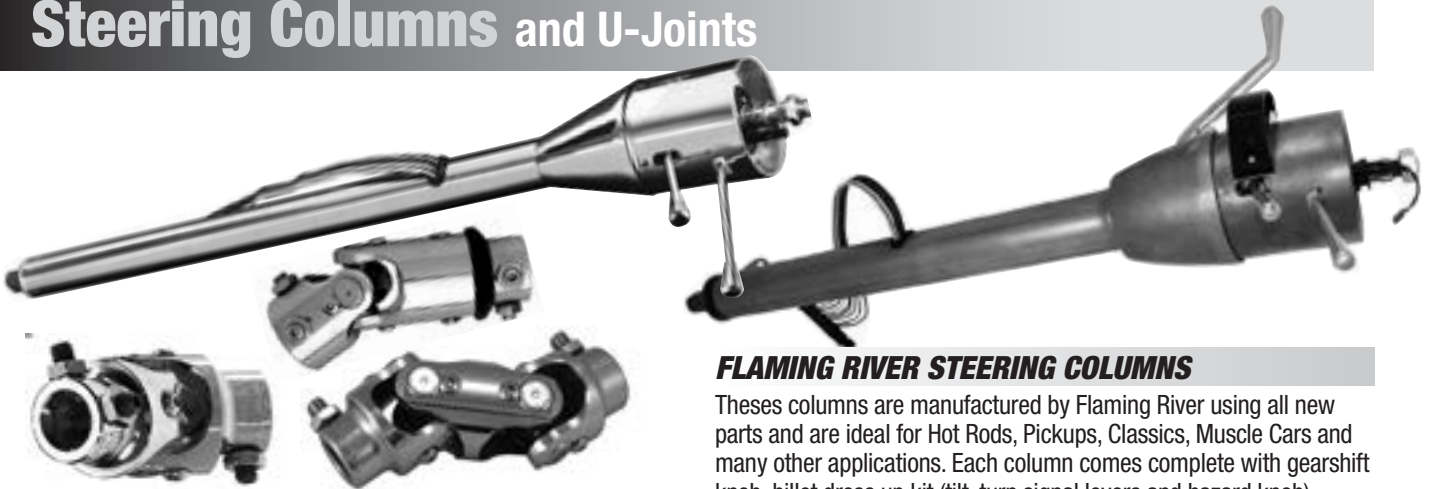

FLAMING RIVER BILLET U-JOINTS

SINGLE U-JOINTS

CNC machined from aircraft steel to precision tolerances. The sealed needle bearing design will last ten times longer than a standard pin and block universal joint. Nickel plating prevents rust without the hassle of painting. Polishing available for a "stainless look" at a nominal charge. Quality at an affordable price.

- Standard finish starts at \$94.95
- Polished finish starts at \$105.95
- Mill finish stainless steel starts at \$104.95
- Polished stainless steel starts at \$129.95

DOUBLE U-JOINTS

Same features of the single u-joint except it accommodates angles up to 60 degrees.

- Standard finish starts at \$174.00
- Polished finish starts at \$194.90
- Mill finish stainless steel starts at \$197.00
- Polished stainless steel starts at \$212.00

VIBRATION RESISTOR U-JOINTS

Incorporates a thermal plastic rubber bushing to dampen "road shock".

- Standard finish starts at \$187.95
- Polished finish starts at \$207.95



FLAMING RIVER STEERING SHAFTS

Stainless steel splined and Double-D shafting available in many sizes and lengths.

- Mill finish stainless DD shaft, 18 to 36" \$65.60- 87.65
- Polished stainless DD shaft, 18 to 36" \$87.65-105.29
- Polished stainless splined shaft, 4 to 36", 3/4"-36 . . \$76.60



FLOOR MOUNT

Billet aluminum ball swivels up to 60 degrees.

- Floor mount 1-3/4" or 2" dia. \$105.95



COLUMN DROPS

Adjustable angle column drop for 1-3/4" or 2" dia.

- 2-1/2 to 6-1/2" drop \$115.95
- 2-1/2 to 6-1/2" drop for keyed column . . \$115.95

FLAMING RIVER STEERING COLUMNS

These columns are manufactured by Flaming River using all new parts and are ideal for Hot Rods, Pickups, Classics, Muscle Cars and many other applications. Each column comes complete with gearshift knob, billet dress up kit (tilt, turn signal levers and hazard knob), illuminated gearshift indicator and GM wiring (4-1/4 in. connector) and removable 12-position linkage arm. Shaft size is 1 in. DD. 2" tube diameter. Combination neutral safety switch/back up light is available and must be ordered with column. Columns are available 28", 30", 32", 33" and 35" long.

All Flaming River columns are made from 304 grade stainless steel, in paintable mill finish OR polished to a high luster. They will never rust and are chemically clean and can be painted to match or highlight an interior with only minor preparation.

FLOORSHIFT TILT

- Mill finish stainless steel starts at \$489.00
- Polished stainless steel starts at \$589.00

COLUMN SHIFT TILT

- Mill finish stainless steel starts at \$789.00
- Mill finish stainless steel w/neutral safety starts at . . \$829.00
- Polished stainless steel starts at \$929.00
- Polished stainless steel w/neutral safety starts at . . \$1,029.00

FLOORSHIFT TILT WITH KEY

Includes GM coded key, wiring, ignition switch

- Mill finish stainless steel starts at \$695.00
- Polished stainless steel starts at \$795.00

COLUMN SHIFT TILT WITH KEY

- Mill finish stainless steel starts at \$889.00
- Polished stainless steel starts at \$1059.00

CRUISE CONTROL

Cruise control can now be added your Flaming River Tilt Column. Designed for non-computer engines. GM-style turn signal lever.

\$299.00



UNISTEER U-JOINTS

Polished stainless steel with long lasting needle bearings and a 38 degree working angle. Uses a pinch bolt for secure mounting. Many possible combinations of: 9/16"-26, 3/4"-36, 3/4"-30, 1"-48 splines, 3/4" smooth and 3/4", 1" DD shafts

- Polished stainless u-joints \$75.00
- DD Shaft, 23" Plated (notched on one end) \$34.00
- DD Shaft, 35" Plated (notched on both ends) \$48.60

GENNIE LO-STIK SHIFTER

The *Gennie Lo-Stik* shifter gives you have the ability to interchange different shifter handles and knobs with ease. The Lo-Stik is a modular system where you choose the correct bracket for your transmission, the Lo-Stik shifter unit, a shift handle and knob. Emergency brake handles are also available that bolt to the transmission bracket. This also allows you to keep the shifter assembly and just change brackets if you change transmission types.

Gennie Shifters use a very positive *Gated Lock Out System* and with the solid steel stick and fewer moving parts, your shifter won't have that annoying rattle!

Lo-Stik features: • Neutral safety switch • Delrin bushings • Hardened Posiloc™ shift gate • 303 Stainless parts • Precision machine fit • Bracket kits include levers, linkage and hardware • boots, bezels and back-up light switch available separately.

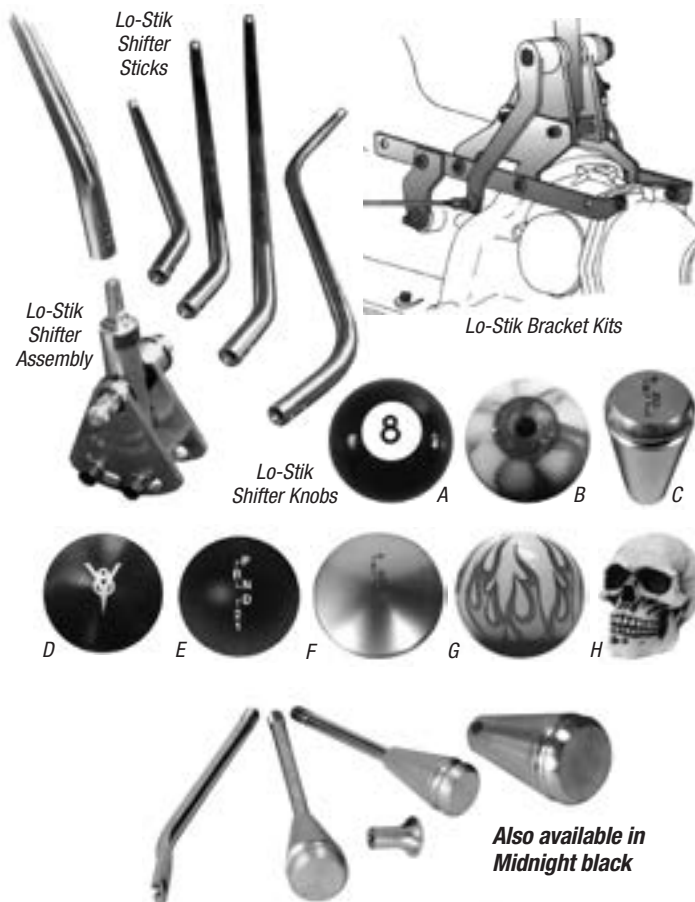

COLUMN DRESS-UP KIT

Stainless shafts with billet aluminum knobs. Tilt, bolt-on or screw-in turn signal lever and hazard knob. Shift lever knob sold separately

- 8050 Column Dress-up kit \$49.95
- 8053 Column Shift Knob \$24.95

STEERING HOOK-UP KITS

Complete Kit, Nothing else to buy. Includes u-joints, column adapter, shafting and hardware. Please specify steering column

- SC250 Mustang Rack -Manual \$185.00
- SC260 Mustang Rack -Power \$185.00
- SC270 Mustang Rack -Manual w/vibration damp.. \$259.00
- SC280 Mustang Rack -Power w/vibration damp... \$259.00
- SC300 Vega Steering Box Kit \$125.00

LO-STIK SHIFTER ASSEMBLY

- 1021 GM transmissions \$214.95
- 1022 Ford and MOPAR transmissions..... \$214.95

LO-STIK TRANSMISSION BRACKETS/LINKAGE, Mid-Mount

- Specify GM transmissions, PG, 350, 400, 700, 4L60, 4L60E, 4L80, 200R4 \$74.95

- Specify Ford C4, C6, FMX, AOD, \$74.95

- Specify Chrysler Torqueflite, \$74.95

LO-STIK TRANSMISSION BRACKETS/LINKAGE, Rear-Mount

- All Ford, Chrysler, GM transmissions..... \$90.95

GENNIE SHIFTER STICKS, polished Stainless

- 8" straight, 10", 12", 16" 23" angle..... \$78.95

- 28" angle \$95.95

- Swan curved \$100.95

GENNIE SHIFTER CUSTOM KNOBS with 5/16-18 insert

- EP1300 (A) Black 8-Ball, thermoset resin, 2.5" dia... \$19.95

- EP1801 (B) Eye Ball, thermoset resin, 2.5" dia \$19.95

- 20008 (C) Aluminum, w/shift pattern (specify) \$14.95

- AL1001 (D) Black V8, aluminum oval \$49.95

- KNOB20011 (E) Black, plastic oval w/shift pattern (specify) \$11.95

- AL1003GS4 (F) Aluminum, oval w/shift pattern (specify).. \$49.95

- EP1405 (G) Flamed Ball, various colors, 2.25" dia ... \$54.95

- SK1001 (H) Skull, hand painted molded resin, 2.75" .. \$19.95

BOOT RING ONLY for using your own boot

- Stainless steel ring only \$26.95

SHIFTER BOOT KITS

Hand stitched vinyl available in black, red, white, tan, maroon or gray. Includes polished stainless steel ring and screws. Black and tan leather also available

- 1005 Shifter Boot kit, mid-mount..... \$54.95

- 1006 Shifter Boot kit, rear-mount..... \$44.95

- 2004 Hand Brake Boot kit, \$44.95

- 2005 Hand Brake Boot kit, Lo-Line \$44.95



KUGEL KOMPONENTS VARI-ANGLE SHIFT ARM KITS

With its unique splined insert the arm can be used at any angle, with any column or floor shifter. Stainless arm is also slotted so shifter or column travel between gears can be matched with the amount of travel needed in the transmission selector.

The arm can be purchased alone or with rods for linking column shifters. Fits GM 350, 400 and 700R transmissions. Kit includes arm, two female heim joints, threaded rod, column bushing and hardware.

- 2040 10-1/2" to 17" w/ short rod \$54.95

- 2041 17" to 23-1/2" w/ long rod..... \$54.95



Gennie Shifters & Lokar Shifters and Hand Brakes

GENNIE SHIFTER HAND BRAKE

These hand brake assemblies are designed to bolt to any Gennie Shifter transmission bracket in the upright position. The handle is 1020 DOM stainless steel tubing with hardened parts. Boot, bracket and cables sold separately.

2001 11" handle assembly \$199.95

2002 16" handle assembly \$199.95



GENNIE SHIFTER LO-LINE FLOOR MOUNT

This hand brake is designed to mount flat to the floor. The handle is 304 stainless steel construction with hardened parts micro switch for indicator light. Boot and cables sold separately.

2003 16" handle assembly \$179.95



GENNIE SHIFTER BRAKE CABLE KITS

Includes 9 feet of heavy-duty cable and hardware to connect Gennie Shifter handbrake handle to most applications. You cut to fit.

2006 GS2* two cables for most drum brakes. \$129.95

2007 GS1* one cable for Jag rear ends \$71.95

2008 UN2* two cables for most drum brakes \$129.95

2009 UN1* one cable for Jag rear ends \$71.95

2010 FF1* one cable for original style Ford underdash handles to UN2 \$71.95

Clevis Clamp kits to adapt cables to different rear ends, 1/4" pin, 5/16" pin, Corvette, Explorer . . . \$10.95

*UN is for universal, GS is for Gennie Shifter handles

TRI-5 CHEVY REPLACEMENT CABLE

This is a direct replacement cable that uses high quality Gennie Shifter stainless steel inner cable. 123" long with correct ends.

2003 1955-57 Chevy \$211.95



LOKAR AUTOMATIC TRANSMISSION SHIFTERS

Lokar Shifters use a safety lock-out button to prevent accidental shifting from park into reverse, drive, and low gears. The safety lock-out button is flush with the knob, and is virtually undetectable. Shifter Knob Adapters are available to personalize their shifter with a custom knob. Lokar's main plate and side brackets allow the shifters to be mounted in a number of positions front to rear.

Features Include • Positive Lock-Out in Park and Neutral with push-button aluminum knob • Neutral Safety Switch • High quality rod ends • Levers available in 32", 23", 16", 12", 10", 8" and 6" lengths • Choice of Teflon-lined shifter knob buttons • Gold irradiated main plate and brackets • All hardware included • Shifter Boots sold separately • Vertical style parking brake handle can be bolted to shifter bracket

For Ford, GM and Chrysler \$363.95

Lokar Shifters are also available in Midnight black

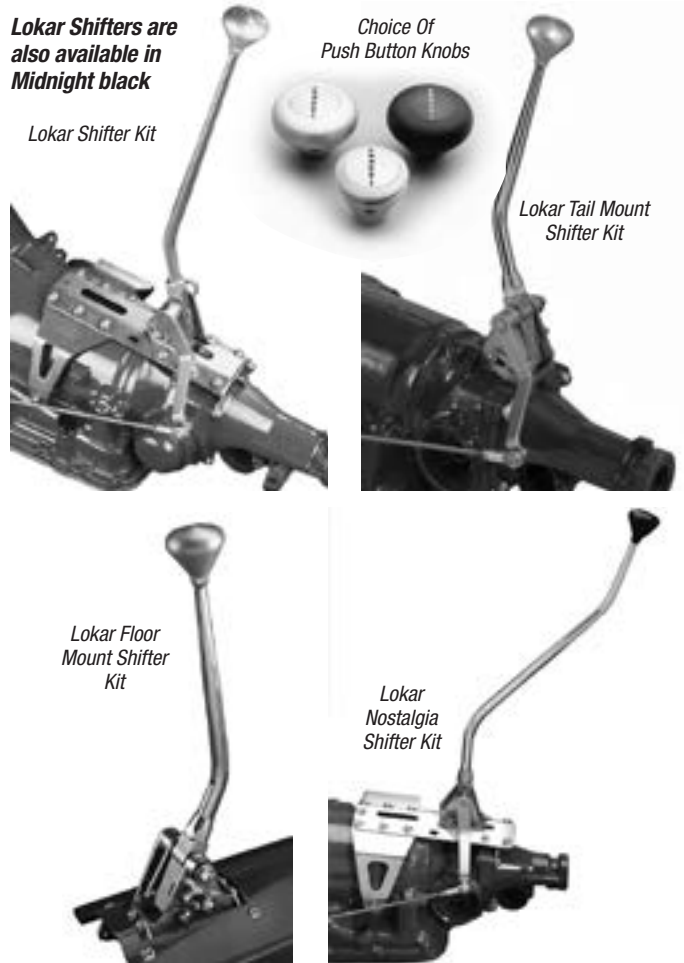

LOKAR TAIL MOUNT SHIFTER

This shifter has most of the same features as the regular shifter except it bolts to the tail shaft bolts. Choice of two positions.

Tail shaft mount for Ford, GM and Chrysler \$349.95

LOKAR FLOOR MOUNT SHIFTER

Bolts to the floor instead of transmission. Includes three different offset levers for clearance. Also available with cable actuation.

Floor mount for Ford, GM and Chry, non-cable style . . . \$395.95

Floor mount for Ford, GM and Chry w/cable, 16" lever. \$395.95

LOKAR NOSTALGIA SHIFTERS

Uses a single or double bend shifter handle 16, 23 or 32" long.

Nostalgia Shifter for Ford, GM and Chrysler, 16-23" . . . \$415.95

Nostalgia Shifter for Ford, GM and Chrysler, 32" \$415.95

Lokar Floor Mount E-Brake Handle

Lokar hand brakes are also available in Midnight black

LOKAR HAND BRAKES

TRANS MOUNT

These hand brake assemblies are designed to compliment the Lokar shifter styling and bolt to the Lokar transmission bracket in the upright position. The chrome handle is available 10 or 16" long. Ratchet gear and lock are hardened for long life and safety. Boot and cables are sold separately.

- EHB-7011 11" handle transmission mount\$211.95
- EHB-7016 16" handle transmission mount\$211.95

FLOOR MOUNT HAND BRAKE

This hand brake has the same features, but is designed to mount flat to the floor. May also be mounted sideways in front of the drivers seat. Unit measures 10" end to end. Boot and cables are sold separately.

- EHB-7000F Floor mount lever.\$221.95
- EHB-7001 Warning light switch kit\$33.95

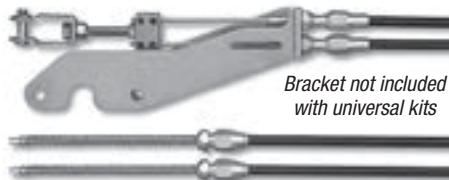

Bracket not included with universal kits

LOKAR BRAKE CABLE KITS

These cable sets are designed to work with the Lokar trans mount hand brake bracket or use the universal kits for the floor mount unit. The universal set does not include the bracket that bolts to the vertical hand brake bracket. Sets include two 8 foot stainless steel cables, ends and hardware. Available with black or braided stainless housing. You cut to fit. Kits are available for Ford, Chevy Chrysler drums, Ford and Lincoln discs, Corvette, Jag, Wilwood, SSBC and Baer discs and universal. Please specify

- EC-80TU Trans mount cables, black housing\$211.95
- EC-80THT Trans mount cables, stainless housing ...\$249.95
- EC-80FU Universal cables, black housing.\$211.95
- EC-80FHT Universal cables, stainless housing\$249.95

UNDER-DASH CONNECTOR CABLES

These cables connect a Lokar under-dash hand or foot operated parking brake to the universal brake cable kit. Single cut to fit cable is 6 foot and available in black or stainless. Also for some factory hand brake handles.

- EC-8001U Universal Connector cable, black\$106.95
- EC-8001HT Universal Connector cable, stainless\$156.95
- EC-8000U Cable for 1937-48 Fords, black.\$106.99
- EC-8000U* Cable for 1937-56 Ford Trucks, black\$106.99
- EC-8002U* Cable for 1937-48 Dodge/Plym, black\$106.99
- EC-8003U* Cable for 1939-48 Chevy, black\$106.99

*specify black or stainless steel outer housing

Lokar Trans Mount E-Brake Handle



LOKAR UNDER-DASH HAND BRAKES

These hand brake assemblies mount under the dash for a clean, out of the way emergency brake. The pedal arm is available solid or with widows and with a ball milled or rubber insert pedal pad. Unit is about 12" high and adjusts from 9 to 13" deep with universal brackets. Use with the connector cables, below left.

- EFB-9000 Billet aluminum w/ball milled pad\$227.95
- EFB-9001 Billet aluminum w/rubber insert pad\$227.95
- EFB-9000 Billet alum. w/windowed arm, ball milled pad . \$227.95
- EFB-9001 Billet alum. w/windowed arm, rubber insert pad . \$227.95

Also available chrome and midnight black



LOKAR BRAKE CABLE CLEVIS KITS

Adapts Lokar cables to disc brake emergency brake linkage

- EC-80WC Wilwood and 1988-up Corvette\$26.95
- EC-80CC 1984-87 Corvette\$34.95
- EC-81FC Ford Explorer\$34.95

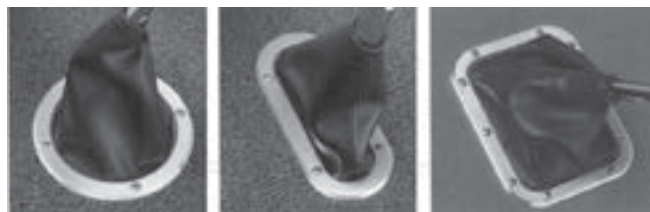

LOKAR BOOT KITS

Lokar boots are black Naugahyde with a polished stainless steel bezel and stainless screws.

- 70-BHRB Shifter boot kit, with round bezel\$44.95
- 70-EHBT Hand brake boot kit\$44.95
- 70-BHBF Floor hand brake boot kit\$44.95

Also available in midnight black. Also available with LED indicators.

B&M QUICKSILVER SHIFTER

The B&M QuickSilver can be ratcheted up or down between neutral and low with the stick remaining in the centered position. When in the drive position, the stick can be pulled up, releasing ratchet mode and allowing lever movement directly to reverse or park. Cable and hardware included. Works with GM TH400, 350, 250, and 200, Ford C4, C6, and AOD, 1966-Up Chrysler Torqueflite A-727 and A-904

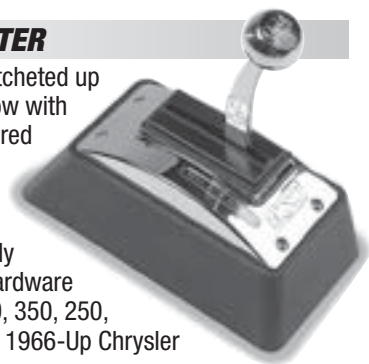

- 80683 Universal.\$359.95

Call 402.886.2275 or click: www.heinzmanstreetrods.com

Lokar Shifters, Hand Brakes & Cables



LOKAR SHIFT KNOBS

Aluminum knobs with teflon lined push-button lockout. Specify with or without shift pattern on button. These work on Lokar shifters only.

- SK-6850 8-ball\$61.99
- SK-6851 Piston\$46.99
- SK-6861 Polished skull with plain button\$73.99
- SK-6862 Polished skull with 3 speed auto button ...\$73.99
- SK-6878 Shift knob adapter for regular 3/8-16 knob ..\$29.95
- SK-6879 Shift knob adapter for regular 3/8-24 knob ..\$29.95

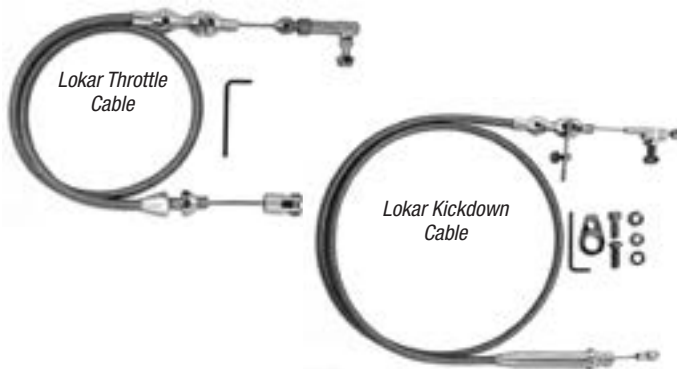

LOKAR THROTTLE & KICKDOWN CABLES

Available with braided stainless or black housing with a specially extruded inner liner and stainless wire. Throttle cable clevis adopts to most factory and aftermarket pedals.

- TC-1000HT 24" stainless steel throttle cable\$75.95
- TC-1000HT36 36" stainless steel throttle cable\$75.95
- TC-1000TP Chevy TPI stainless steel throttle cable ..\$75.95
- TC-1000LS1 Chevy LS1 Ramjet SS throttle cable\$62.95
- TC-1000TPV Chevy Vortec SS throttle cable\$59.95
- KD-2350HT GM TH-350 Kickdown SS cable.\$115.99
- KD-22400HT GM TH-400 Kickdown SS cable.\$115.99
- KD-20PGHT GM Powerglide Kickdown SS cable\$115.99
- KD-2700HT GM 700R4 Kickdown SS cable\$115.99
- KD-2200RHT GM 200-4R Kickdown SS cable.\$115.99
- KD-20C4HT Ford C4 Kickdown SS cable\$115.99
- KD-20C6HT Ford C6 Kickdown SS cable\$115.99
- KD-2A0DHT Ford AOD Kickdown SS cable\$115.99
- KD-2727HT Chrysler 727 Kickdown SS cable\$115.99
- KD-2904HT Chrysler 904 Kickdown SS cable\$115.99



LOKAR THROTTLE PEDALS

Lokar throttle pedals are available in chromed steel or billet aluminum. Throttle pad is spring loaded and lower arm is splined and can mount on right or left side of bracket. Brake pads have a 1/2 x 20 stud.

- SPO-6070 Chromed steel spoon throttle\$61.55
- SPO-6071 Chromed steel round brake pedal\$43.95
- SPO-6071 Chromed steel round dimmer\$23.95
- SG-6007 Chromed steel throttle pedal\$150.95
- SG-6008 Chromed steel rectangular brake pedal\$59.95
- SG-6009 Chromed steel rectangular dimmer\$21.95
- BAG-6001 Billet throttle pedal\$135.95
- BAG-6002 Billet rectangular brake pedal\$45.95
- BAG-6003 Billet rectangular dimmer\$21.99
- BAG-6004 Billet throttle pedal w/rubber insert.\$135.95
- BAG-6005 Billet rectangular brake pedal w/rubber ...\$45.95
- BAG-6006 Billet rectangular dimmer w/rubber\$21.95

LOKAR THROTTLE CABLE BRACKET AND SPRING

Polished stainless bracket mounts to the back bolt on Holley, Edelbrock, Carter, demon and in-line dual quads. Locates the throttle and kickdown cable and spring.

- SRK-4000 Carburetor bracket and spring\$44.95
- TRP-4003 Rochester tri-power bracket and spring ...\$46.95
- TCB-40LT1 Chevy LT-1 bracket\$61.95
- TCB-40LT4 Chevy LT-4 bracket\$61.95
- TCB-40EFI 1986-93 Ford EFI bracket\$61.95
- TCB-40RJ Chevy Ramjet EFI bracket\$61.95



PHOENIX TV CABLE CARBURETOR LEVER

We use these handy Phoenix Transmission Products TV cable correction brackets for the Holley, Demon and Edelbrock carburetors. These simply bolt to your existing carb linkage with included hardware and provide perfect TV geometry for proper operating pressure and shift timing for TV cable equipped 700R4, 2004R, and Ford AOD. Use with Lokar or OEM TV cables.

- PTVLVRHLY Holley carbs\$31.00
- PTVLVRAFB Edelbrock and Carter\$31.00
- PTVLVRBG Barry Grant\$31.00

NO-SLIDE TV AND THROTTLE CABLE BRACKET

TV (throttle valve) cables offer a lot more tension than old style kick-down cables and can sometime pull carb brackets out of adjustment. This bracket bolts between the carb and manifold and can't move.

- Four barrel Holley and Edelbrock carbs\$49.95

Lokar Shifters and Hand Brakes



LOKAR DIP STICKS

Lokar teflon lined braided stainless engine and transmission dipsticks use an easy to read teflon inner rod that's calibrated for each application. Transmission dipstick is available with a bell housing bracket or firewall mounting. All firewall mount are 24" long. Dipstick seals with o-rings. Transmission kits include a funnel adapter for easy filling. Engine dipsticks have brackets for factory or Sanderson headers

- Firewall mount for most transmissions\$139.95
- Bell housing mount for most transmissions\$139.95
- ED-5001 Engine, Small Block Chevy, 1980 up\$61.95
- ED-5003 Engine, Big Block Chevy\$61.95
- ED-5006 Engine, 502 Big Block Chevy\$61.95
- ED-5004 Engine, 302 Ford, 1986-95\$61.95
- ED-5010 Engine, 289-302 Ford, 1962-69\$61.95
- ED-5008 Engine, GM LS1, 1997 up\$61.95

LOKAR HOOD & TRUNK CABLE RELEASE KITS

Billet aluminum handle with braided stainless or black housing with a specially extruded inner liner and stainless wire. Hood release cable is 6 feet and trunk is 15 feet and are cut-to-fit. A combination unit is also available. Cable operated mechanisms are required.



- CHT-1300HT Combination release, stainless cable...\$210.95
- CHT-1300U Combination release, black cable.....\$171.95
- TR-1200HT Trunk release, stainless cable.....\$124.95
- TR-1200U Trunk release, black cable.....\$99.99
- HR-1100HT Hood release, stainless cable.....\$109.95
- HR-1100U Hood release, black cable.....\$89.99



LOKAR HEADLIGHT CONDUIT

Lokar teflon lined braided stainless headlight wire covers are designed with a threaded steel stud and aluminum ends. Includes headlight wires.

- HL-1900 Stainless Headlight Braid, 12" long.....\$96.99



LOKAR COLUMN DRESS-UP KIT

Machined from billet aluminum in one piece with a satin finish. Fits all GM columns and includes the turn signal and tilt lever and flasher button.

- DUK-2200 Column dress-up kit\$53.95



LINE CLAMPS

Kugel Komponenten' stainless steel hold down clamps are available in a variety of configurations and sizes. They're used to secure items like hard lines, hoses, cables, and wire looms to the frame or body. Packaged with stainless steel 10/32 button head allen screws and stainless steel sheet metal screws. Many more combinations than we can list here, so give us a call. Only one size per pack.

- Single clamps, 3/16, 1/4, 5/16, 3/8, 1/2, 12/pack\$19.95
- Single clamps, 5/8, 3/4, 7/8, 8/pack\$19.95
- Double clamps, 3/16, 1/4, 5/16, 3/8, 1/2, 6/pack\$19.95
- Double clamps, 5/8, 3/4, 7/8, 4/pack\$19.95
- Combination clamps, 3/16 x 3/8 or 5/16 x 3/8 6/pack ..\$19.95



Lokar Shifters and Hand Brakes

Bumpers, Guards and Braces

1928-1948 Ford Reproduction Parts



BUMPERS

High quality exact reproductions of original bumpers are available chrome plated or in polished stainless steel. Does not include bolts.

Chrome Stainless

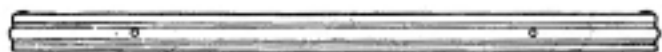

B-17750 1932, front or rear \$400.00 N/A



40-17750-A 1933, front or rear \$400.00 \$515.00



40-17750-B 1934, front or rear \$400.00 \$515.00

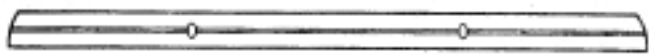

46-17750 1934 Pickup front \$400.00 \$515.00



48-17750 1935, front or rear \$400.00 \$515.00



68-17750 1936, front or rear \$400.00 \$515.00



50-17750 1935 Pickup front \$400.00 \$515.00

67-17750 1936 Pickup front \$400.00 \$515.00

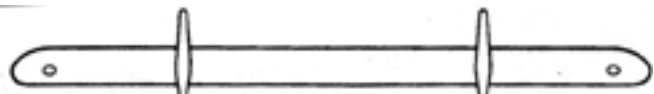

78-17750-A 1937 front \$400.00 \$515.00

78-17750-D 1937 rear \$400.00 \$515.00

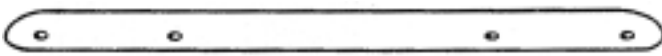

81A-17750 1938-39 standard \$400.00 \$515.00



91A-17750 1939 deluxe, front or rear . . . \$400.00 \$515.00

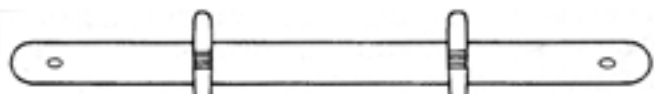

01A-17750 1940, front or rear \$350.00 \$515.00



01A-17821/2

01A-17754/5

01A-17821/2-SS

BUMPER BRACES

High quality reproduction bumper brackets are available in plain steel or polished stainless steel. Most are also available as "snug" versions to pull bumpers closer to the body. Please call.

Add "SS" to part number for stainless steel.

		Steel	Stainless
B-17754/5	1932 Front, set.	\$100.00	\$250.00
B-17821/2	1932 Rear, set.	\$100.00	\$250.00
18-17754/5	1933 Front, set.	\$165.00	\$395.00
18-17821/2	1933 Rear, set.	\$100.00	\$395.00
40-17754/5	1934 Front, set.	\$165.00	\$395.00
40-17821/2	1934 Rear, set.	\$100.00	\$395.00
48-17754/5	1935 Front, set.	\$165.00	\$395.00
48-17821/2	1935 Rear, set.	\$100.00	\$395.00
68-17754/5	1936 Front, set.	\$165.00	\$395.00
48-17821/2	1936 Rear, set.	\$100.00	\$395.00
78-17754/5	1937 Front, set.	\$165.00	\$395.00
78-17821/2	1937 Rear, set.	\$165.00	\$395.00
01A-17754/5	1940 Front, set.	\$165.00	\$395.00
01A-17821/2	1940 Rear, set.	\$165.00	\$395.00



BUMPER BOLTS

High grade polished stainless steel.

B-17758	1932 Bumper bar bolts.	each \$15.00
B-17760	1932 Bumper bar end plug.	each \$6.00
48-17758	1935-40 Oval, stainless head.	each \$7.50
40-17758	1933-34 Round, chrome head.	each \$6.00
11A-17758	1941-48.	each \$10.00



40-17796-S

48-17796-S

78-17796-S

40-17796-S

BUMPER GUARDS

Heavy stamped steel with quality chrome plating.

40-17796-S	1933- 34.	each \$50.00
48-17796-S	1935- 36.	each \$50.00
78-17796-S	1937.	each \$50.00
01A-17796S	1940 Deluxe.	each \$50.00



BUMPER ARM GROMMETS

FRONT

48-17772	1935	pair	\$20.00
50-17772/3	1935-37 Pickup	pair	\$20.00
68-17772/3	1936-37	pair	\$20.00
81A-17772/3	1938 Deluxe, 39 Standard	pair	\$20.00
81C-17772/3	1938-39 Pickup	pair	\$20.00
91A-17772/3	1939- 40 & 1940-41 Pickup	pair	\$20.00
11A-17772/3	1941 All body styles	pair	\$20.00

REAR

78-17792/3	1937 All Bodies, 1938- 40 Coupe	pair	\$20.00
81A-17792/3	1938-40 Sedan, Tudor & Fordor	pair	\$20.00
11A-17792/3	1941 All Bodies	pair	\$20.00

LICENSE PLATE BRACKET ASSEMBLIES

FRONT



B-5034-B	1932 Black	\$20.00
B-5034-C	1932 Stainless	\$25.00
40-5034-B	1933-36 Black	\$20.00
40-5034-C	1933-36 Stainless	\$25.00
91A-5034	1939-40 Black	\$20.00
91A-5034-C	1939-40 Chrome	\$25.00

REAR



B-13406-A	1932	\$15.00
B-13406-C	1932, Chrome	\$25.00
40-13406-C	1933-34, Chrome	\$25.00
40-13406-A	1933-36	\$15.00
01A-13406	1938-48	\$20.00
01A-13406SS	1938-48 stainless	\$25.00



LICENSE PLATE FRAMES

Polished stainless steel frame. Simple and good looking.

HR13409	each	\$20.00
Chromed die cast frame with license light.		
CHR9980	With light	\$29.95



1932 FORD SPREADER BAR LICENSE BRACKET

Made from aluminum billet, they clamp to 1-1/4" front spreader bar tube and bolt together through license plate holes.

3326F	1932 Front bracket	\$60.00
3326R	1932 Rear bracket	\$48.00

See page 6 for 1932 spreader bars.

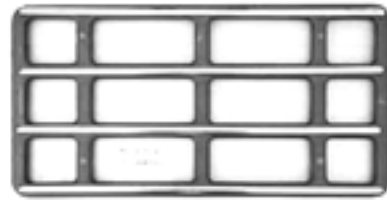

LUGGAGE RACKS

Die-stamped steel ready for paint. Includes stainless trim, brackets and hardware.

A-18575B	1928-31	\$149.95
B-18575	1932	\$325.95
40-18575	1933-34	\$565.00
48-18575	1935-36	\$565.00



1932-34 INSERTS AND GRILLES

1932 is original style with or w/o crank hole fits original and glass grille shells. Stainless bars and outer trim. Can be painted. 1933-34 are beautifully chromed die stamped reproductions.

1932 Insert, polished stainless with or without crank hole		\$315.00
18-8234	1932 Grille Trim fits between shell and hood	\$40.00
C-433	1933 Chrome, Nottingham Reproduction	\$1900.00
C-432	1934 Chrome, Bob Drake	\$2400.00
40-8434	1934 Grill Trim, polished stainless	\$80.00



Ask about trim hardware!

1935-39 GRILLE TRIM

Beautiful stainless or chromed die stamped reproductions.

48-8234	1935 Grille and outside trim set	\$130.00
68-8157	1936 Grille center trim	\$125.00
68-8154/5	1936 Grille side trim	pair \$125.00
78-8200-GTS	1937 Grille center and side trim set	\$150.00
81A-8157-BK	1938 Grille chrome center and hood kit	\$550.00
91A-8157-A	1939 Standard grille chrome center trim	\$395.00
91A-8332-KC	1939 Grille center and side trim set	\$450.00

1928-1948 Ford Reproduction Parts



01A-8200-B

01A-8242



01A-16140

01A-8206

GRILLES

- 01A-8200-B 1940 Standard, 40-41 PU painted . . .pair **\$1,750.00**
- 01A-8242 1940 Standard, chrome center strip N/A
- 01A-8206 1940 Deluxe, chrome grille. pair **\$1,295.00**
- 01A-16140 1940 Deluxe, side vent panels. pair **\$425.00**



RADIATOR ORNAMENTS

- B-8215 1932 Ford **\$40.00**
- 40-8215 1934 Ford **\$40.00**
- 48-8215 1935 Ford **\$125.00**
- 68-8215 1936 Ford **\$125.00**
- 46-8218 1934-35 Ford Pickup **\$75.00**
- 67-8218 1936 Ford Pickup **\$125.95**

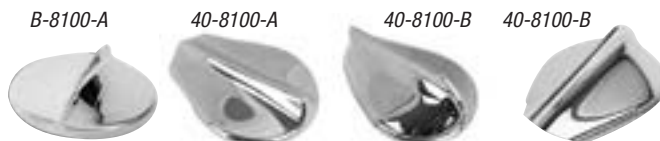

RADIATOR CAPS

- B-8100 1932 **\$40.00**
- 40-8100-A 1933 Passenger **\$40.00**
- 40-8100-B 1934 **\$40.00**
- 46-8100 1933-36 Pickup **\$40.00**



BLUE PORCELAIN OVAL FORD RADIATOR EMBLEM

- B-8212 1932 Passenger and 32-35 Pickup **\$34.95**
- 1B-8212 1933 each **\$34.95**
- 40-8212 1934 each **\$34.95**
- 48-8212 1935-36 each **\$34.95**



GRILLE EMBLEMS

- 40-8217-A 1933 Passenger and 33-35 Pickup **\$40.00**
- 40-8217-B 1934 Passenger **\$40.00**
- 78-8213-A 1937 Passenger **\$50.00**



HOOD RELEASE HANDLE

- 78-8215 1937 Hood release handle, each **\$65.00**
- 78-8218 1937 Hood release handle base **\$45.00**
- 91A-8215 1939 Deluxe hood handle **\$50.00**
- 01A-8215-A 1940 Hood release, standard **\$75.00**
- 01A-8215-B 1940 Deluxe, hood release handle **\$75.00**
- 01C-8215 1940 Pickup, hood release **\$75.00**

1933-34 FRONT FENDER SPACER CLAMP

- 40-16088 Front fender spacer clamp **\$20.00**
- 40-16088-C Front fender spacer clamp, Chrome **\$30.00**



Hood and Body Trim



FRONT HOOD ORNAMENT

The hood release hand is not included.

- 01A-8218B 1940 Deluxe \$349.95
- 01A-8218A 1940 Standard \$349.95
- 01C 1940 Pick-up \$349.95

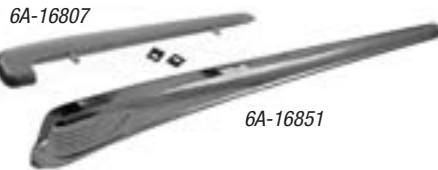

1947-48 HOOD ORNAMENT

- 6A-16807 Hood ornament insert, blue plastic \$25.00
- 6A-16851 Hood ornament chrome \$225.00

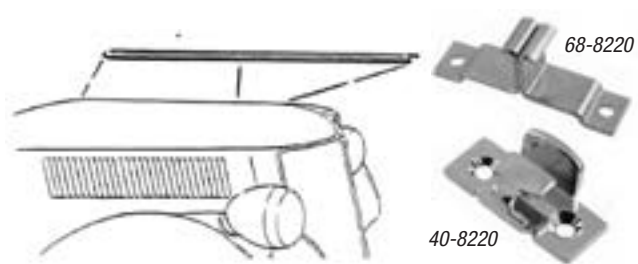

HOOD CENTER HOOD HINGE AND BRACKETS

- B-116632 1932 Center Hood Hinge, Stainless \$30.00
- 40-16632 1933-36, Center Hood Hinge. each \$30.00

CENTER HINGE BRACKETS

- B-8220 1932 Pass Front, 33-34 Pass Rear, chrome . . \$10.00
- B-8221 1932 Pass Rear, chrome \$15.00
- 40-8220 1932-35 Pass Front; 33-36 Pass Rear \$10.00
- 68-8226 1936 Pass Front. \$10.00



1928-32 HOOD LATCHES

- A-16750A 1928-29 Polished stainless. \$12.00
- A-16750AP 1928-29 Rubber pad for hood latch. \$8.00
- A-16750B 1930-31 Polished stainless. \$12.00
- A-16750BP 1930-31 Rubber pad for hood latch. \$8.00
- B-16750 1932 Hood latch, black. \$8.00
- B-16750SS 1932 Hood latch, pol. stainless. \$25.00
- B-167551S 1932 Hood panel clips, pol. stainless set. . . \$65.00
- 3287 1932 Stainless hood handles pair \$35.00

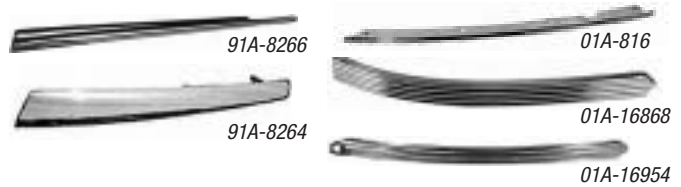

SIDE AND LOWER HOOD TRIM

- Beautiful polished stainless reproductions. Clips are sold separately.
- 48-16722-SS 1935 hood side louver trim, 8 pieces . . \$140.00
 - 68-16722-S 1936, hood side louver trim, 6 pieces. . . \$140.00
 - 91A-16736 1939 Deluxe hood center trim. \$55.00
 - 01A-16736-A 1940 standard hood center trim. \$55.00
 - 01A-16736-B 1940 Deluxe hood center trim. \$55.00
 - 01C-16736 1940-41 Pickup hood center trim. \$55.00

HOOD LOWER FRONT SIDE TRIM over grille

- 91A-8266/7-B 1939 Deluxe "Cat Wiskers", chrome . pair \$60.00
- 91A-8264/5 1939 Deluxe-chrome pair \$180.00
- 01A-8216 1940 Standard-stainless. pair \$65.00
- 01A-16868/9 1940 Deluxe "big" -stainless pair \$95.00
- 01A-16954/5 1940 Deluxe "small" -stainless pair \$75.00
- 11C-8264/5 1941 Pickup-chrome. pair \$180.00



HOOD HINGES

- 78-16796 1937 Hood hinges pair \$75.00
- 91A-16796 1938-40 Hood hinges pair \$75.00
- 78-16746/47-S 1937-'41 Hood hinge pads pair \$5.00
- 91A-16789 1939-40 Hood hinge springs pair \$9.50
- 91A-16782 1939 Stand, 40-41 hood support arms. pr \$90.00
- 91A-16802 1939 Deluxe, 40 hood support arms . . pr \$90.00

BODY SIDE TRIM

These are beautifully polished stainless reproductions. We have side trim for most years. Please inquire. Clips are sold separately. **Specify right or left hand.**

- 01A-7020935 1940 Door trim, convert, 2 door each \$60.00
- 01A-7320935 1940 Door trim, coupe, 4 door front.. each \$60.00
- 01A-16723-A 1940 Standard Hood trim each \$60.00
- 01A-16722-B 1940 Deluxe Hood trim each \$60.00
- 01A-6629045-B 1940 Quarter trim, convert. each \$80.00
- 01A-7729035 1940 Quarter trim, coupe. each \$80.00
- 01A-7029035 1940 Quarter trim, 2 door. each \$80.00
- 01A-7325555 1940 Door trim, 4 door rear. each \$60.00
- 78-741234/5-K 1937-40 Convertible Windshield Trim . set \$375.00



HOOD PARTS

- 40-16628-B 1933 Hood catch bracketset \$20.00
- 40-16628-C 1934 Hood catch bracket on grille.set \$10.00
- 40-16628-B 1933 Hood catch bracketset \$10.00
- 91A-16610 1939-47 Hood shoulder bolt. each \$1.25

Call 402.886.2275 or click: www.heinzmanstreetrods.com



48-702353

B-702352

78-702352

01A-7043500

51A-7043511

DECK LID HANDLES

A-702352-A	1928-31 Coupe & Roadster	each	\$27.50
A-702352-B	1930-31 Cabriolet, scroll-type	each	\$35.00
A-41648	Deck Handle Pad	each	\$2.00
B-702352-C	1932-34 Deck Handle, Cast	each	\$40.00
48-702352-C	1935-36 Deck Handle, Cast	each	\$40.00
78-702352	1937 Deck Handle, Cast	each	\$40.00
01A-7043500	1940 Deck Handle & Base	each	\$125.00
51A-7043511	1941-48 Trunk Handle	each	\$125.00



91A-7744200

TRUNK ARM & SPRING SUPPORT

A-41530	1932	pair	\$45.00
40-727690A	1933-34	pair	\$45.00
48-727690A	1935-36	pair	\$45.00
91A-7744200	1939-40 Coupe & Conv.	pair	\$150.00
11A-7744200	1941-48 Coupe & Conv.	pair	\$150.00

DECK LID HANDLE PADS

B-41648	1932-37	each	\$3.00
81A-13572	1938-39	each	\$10.00
99A-13572	1940	each	\$7.50
11A-13573	1941-48	each	\$7.50



TRUNK AND RUMBLE LATCHES

A-52501	1928-29 Lock 1" tall	each	\$35.00
A-52502	1930-31 Lock 1-1/2" tall	each	\$35.00
B-527102	1933-34 & 32 3-window, all rumble	each	\$35.00
B-52502	1932 Trunk and rumble	each	\$35.00
48-52502	1935-36 Trunk and rumble	each	\$35.00
78-52502	1937 Trunk and rumble	each	\$35.00
81A-52502	1938 All, 39 Sedan trunk	each	\$35.00
01A-52502	1940 Sedan trunk	each	\$35.00
11A-52502	1941-48 Sedan trunk	each	\$35.00
91A-70443200-A	1939-40 Coupe and convert.	each	\$35.00
21A-52502	1942-48 Coupe and conv. trunk	each	\$35.00

TRUNK LATCH STRIKER PLATES

40-765680	1933-34 all, rumble lid	each	\$45.00
01A-52500-A	1940 Coupe & convertible	each	\$45.00

TRUNK AND RUMBLE LATCHES (continued)

01A-52500-B	1940 Sedan	each	\$35.00
11A-52500	1941 All, 42-48 Sedans	each	\$35.00
21A-52500	1942-48 Coupes & Conv	each	\$35.00

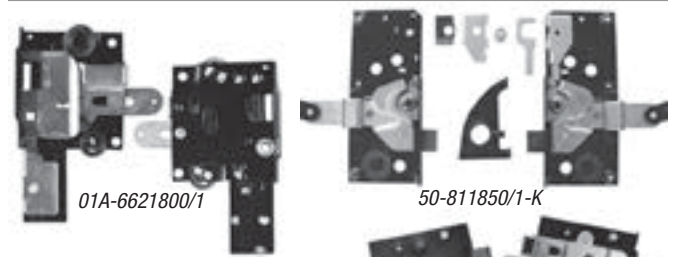

01A-6621800/1

50-811850/1-K

DOOR LATCHES

High quality exact reproductions of the originals.

01A-6621800/1	1935-40 Open Car	pair	\$200.00
01A-7021812/3	1938-40 Coupe, Sedan, Delivery	pair	\$150.00
50-811850/1-K	1935-37 PU, complete kit	pair	\$250.00



B-35705-SS

40-702340-A

81A-702340

40-711830-B

01A-702340

DOOR STRIKER PLATES

B-35705-SS	1932 Roadster, Phaeton, Stainless	each	\$12.00
40-702340-SS	1932-34 Closed, Stainless	each	\$12.00
40-711830-B	1933-35 Roadster, Phaeton	each	\$12.00
81A-702340	1935-39 Car, 35-47 Pickup	each	\$12.00
81A-702340-SS	1939-40 Convertible, Stainless	each	\$12.00
01A-702340	1940 Closed	each	\$12.00
11A-702340	1941-48	each	\$12.00

11A-702340



B-46421

B-35582

40-402550-D

48-702550-A

11A-7023006-A

MALE DOVETAILS

B-35582	1932 Roadster, Phaeton, SS	each	\$12.00
B-46421	1932 Closed Car, 32-34 PU, SS	each	\$12.00
40-402550-D	1933-34 Closed Car, 35-41 PU, SS	each	\$12.00
48-702550-A	1935-40 Car, stainless	each	\$12.00
11A-7023006-A	1941-48 All, 42-47 PU, SS	each	\$12.00



DOOR LOCK ASSEMBLY

Fits right door below handle. Complete with keys (each)

1A-7121984	Door Lock	each	\$35.00
------------	-----------	------	---------

1928-1948 Ford Reproduction Parts

1928-1948 Ford Reproduction Parts



FEMALE DOVETAILS

- B-35576-S 1932-34 Open Car pair \$12.50
- 40-35576 1932-34 Closed Car. pair \$16.00
- 40-35576-C 1932-34 Closed Car stainless \$25.00

DOVETAIL REPAIR KITS

- 48-702574-RK 1935-40 Kit \$10.00
- 11A-702574-RK 1941-48 Kit \$10.00



OUTSIDE DOOR HANDLES

- A-702350AL 1928-29 Locking each \$35.00
- A-702350BL 1930-31 Locking each \$35.00
- A-702350-A 1928-29 Non-locking. each \$35.00
- A-702350-B 1930-31 Non-locking each \$35.00
- B-702350 1932 Chrome plated, R.H. each \$35.00
- B-702351 1932 Chrome plated, L.H. each \$35.00
- 46-702350 1932-34 Pickup Chrome plated. each \$35.00
- 40-70235 1933-34 Chrome plated, R.H. each \$35.00
- 40-702351 1933-34 Chrome plated, L.H. each \$35.00
- 48-702350 1935 Pass. each \$35.00
- 68-702350 1936 Standard each \$35.00
- 68-702350B 1936 Deluxe each \$35.00
- 78-702350 1937 Pass. each \$35.00
- 81A-702350 1938 Pass. each \$35.00
- 91A-702350 1939 Pass. each \$35.00
- 01A-702350 1940 Pass. each \$35.00
- 6A-702350 1947-48 Pass. each \$35.00

OUTSIDE DOOR HANDLE PADS

Moulded Rubber

- B-702356-AS 1932-34, Open Cars pair \$5.00
- B-702356-BS 1932-34 Closed Cars pair \$5.00
- 48-702356-S 1935-37 All Cars. pair \$5.00
- 81A-702356-S 1938-39 All Cars. pair \$5.00
- 99A-702356-AS 1939-40 Closed Cars pair \$5.00
- 01A-702356-BS 1940 Convertibles. pair \$5.00



UNIVERSAL BEAR CLAW ROTARY LATCHES

Two-stage mechanism measures 4-1/2" long, 1-7/8" wide, 7/8" thick. RL-90 has provisions for a 3/8" square shaft handle and the RL-60 is deal for a remote handle application. RL-45 is best for truck or hood atch. Includes striker pins

- RL-90 pair \$90.00
- RL-60 pair \$60.00
- RL-45 pair \$60.00
- SRS HL200 Bearclaw latch and striker mounting plates . pair \$44.95



- SRS-201 VW style small hood latch, cable release \$79.95



FRONT DOOR HINGE KIT

These precision cast steel hinges replace worn or missing originals. Have a clever threaded inside plate that replaces the original rivets.

- 78-702456-K 1937-40 door hinge kit-R & L front doors. \$250.00



STAINLESS STEEL HINGE PINS

- 3373A 1928-31 Model A, polished. each \$5.00
- 3373 1932-48 Ford, polished each \$5.00



DOOR WINDOW REGULATORS

High quality reproductions of the original with black finish. Specify right or left.

- A-48105 1928-31, 3 Mounting Holes, R or L... each \$35.00
- A-48105 1928-31, 4 Mounting Holes, R or L... each \$35.00
- A-48141 1928-31 Rubber window stop bumper \$1.00
- B-702700 1932, Right or left hand each \$85.00
- 18-702700 1933, Right or left hand each \$150.00
- 40-702700 1934, Right or left hand each \$150.00
- 50-812700/1 1935-37 Pickup..... pair \$150.00
- 81C-812700/1 1938-47 Pickup..... pair \$150.00
- 01A-6623200/1 1940 Convertible pair \$200.00
- 01A-7023200/1 1940 two door sedan..... pair \$150.00
- 01A-7323200/1 1940 Coupe, 4 Door pair \$150.00
- 7C-7323200/1 1948-52 F-1 Pickup..... each \$84.95



INSIDE DOOR HANDLES

- B-702400E 1932 each \$12.00
- 40-702400E 1933-34..... each \$12.00
- 48-702400E 1935 each \$12.00
- 48-702400E 1936 each \$12.00
- 01A 702400 1940 each \$15.00
- 01A 702400 1941-48..... each \$15.00

INSIDE WINDOW RISER HANDLES

- B-702780E 1932 each \$14.00
- 40-702789E 1933-34..... each \$14.00
- 48-702780E 1935 each \$14.00
- 68-702780E 1936 each \$14.00
- 01A-702780 1940 each \$15.00
- 11A 702780 1941-48..... each \$15.00

UNIVERSAL ESCUTCHEON PLATE

For door handle & window riser, spring loaded.

- B-48139A \$4.00



SCUFF PLATES

- B3381 1932 Closed Car \$50.00
- 40-7013250 1933-34 Pass..... \$225.00

SCUFF PLATES (continued)

- 48-7013250 1935-36 Passenger..... \$225.00
- 78-7013250 1937 Passenger..... \$225.00
- 81A-7013250 1938-39 Passenger..... \$90.00
- 01A-7013250 1940 Passenger..... \$90.00

Please specify body type

SUICIDE DOOR LOCK

This simple door lock kit is a slide arm type. You can see at a glance if the door is locked or not. Lock Kit comes complete with snap-in bezels for the door jambs, all the hardware needed to complete both doors and black knobs. Kit also includes built in micro switched for dash indicator lights (lights not included).



- 40-46105/6-SDL..... pair \$114.95

METAL DOOR CHECK ARM KIT

- B-702828-S 1932-48 \$10.00
- B-46582 Door check bumper..... pair \$3.00



DOOR CHECK STRAP

- B-162592 1932 3-window & 33-34 closed cars..... \$6.00



METAL GLASS CHANNEL

Metal channels that connect the door and quarter window glass to the window regulator mechanism

- A-45962 1928-31 Coupe and Tudor..... each \$15.00

FRONT DOOR WINDOWS

- | Left Side | Right Side | | |
|------------|------------|-------------------------|--------------|
| B-45963 | B-45962 | 1932 Fordor, 5-W | each \$35.00 |
| 18-45963 | 18-45962 | 1932 3-Window | each \$35.00 |
| B-55963 | B-55962 | 1932 Tudor | each \$35.00 |
| 40-45963-A | 40-45962-A | 1933 Fordor, all coupes | each \$35.00 |
| 40-55963-A | 40-55962-A | 1933 Tudor | each \$35.00 |
| 40-45963-B | 40-45962-B | 1934 Fordor, all coupes | each \$35.00 |
| 40-55963-B | 40-55962-B | 1934 Tudor | each \$35.00 |
| 48-45963 | 48-45962 | 1935-36 Fordor, all cps | each \$35.00 |
| 48-55963 | 48-55962 | 1935-36 Tudor | each \$35.00 |
| 78-45963 | 78-45962 | 1937-39 Fordor, all cps | each \$35.00 |
| 78-55963 | 78-55962 | 1937-39 Tudor | each \$35.00 |
| 01A-45963 | 01A-45962 | 1940 Fordor, coupe | each \$35.00 |
| 01A-55963 | 01A-55962 | 1940 Tudor | each \$35.00 |

TUDOR SEDAN REAR QUARTER WINDOWS

- B-56788-A B-56787-A 1932 Tudor each \$35.00
- B-56788-B B-56787-B 1933 Tudor each \$35.00
- 40-56788 40-56787 1934-40 Tudor each \$35.00

PICKUP WINDOWS

- 77-55963 77-55962 1935-37 Pickup each \$35.00
- 81C-55963 81C-55962 1938-1942 Pickup each \$35.00

1928-1948 Ford Reproduction Parts



WINDOW CHANNEL KITS

These kits are exact replacements of originals and include everything you need to do two front or rear doors or two rear quarter windows. Upper window seal and window seal adhesive and screws and door clips are provided in the appropriate kits. Door-to-glass bumpers, which fit into holes in door and garnish molding, are supplied also. 1934 to 1936 cars came with either front and center inside window handles. Use the appropriate kit (marked with a "C" or an "F" at the end of the part number). All 1937-1939 kits are provided with screws to mount one-sided felt to doors and garnish moldings. Due to the high costs of the original 1937-1939 style clips, a separate clip kit has been made for these years. It consists of 35 original-style punch-in clips and 35 original-style snap-on clips used on the garnish moldings, enough to do two doors or two rear quarters.

COUPE AND SEDAN FRONT DOOR WINDOW KITS

B-45983-3W	1932 3-window coupe	\$120.00
B-45983-5W	1932 5-window coupe	\$120.00
B-45983-2D	1932 Tudor sedan	\$120.00
B-45983-4D	1932 Fordor sedan	\$120.00
B-45983-V	1932 Victoria	\$120.00
18-45983-3W	1933 3-window coupe	\$120.00
18-45983-5W/4D/2D	1933 5-window coupe Tudor sedan and Fordor	\$120.00
40-45983-3W	1934 3-window coupe	\$199.95

Choose front or center handle kits for the following:

Front Handle	Center Handle	
40-45983-2DF	40-45983-2DC	34 Tudor sedan\$199.95
40-45983-5WF/4DF	34 5-W, Fordor\$199.95
	40-45983-5WC	34 5-window coupe ..\$199.95
	40-45983-4DC	34 Fordor sedan.....\$199.95
48-45983-2DF		35 Tudor sedan \$199.95
48-45983-5WF/4DF		35 5-W, Fordor\$199.95
	48-45983-2DC	35-36 Tudor sedan. ...\$199.95
	48-45983-5WC/4DC	35-36 5-W, Fordor ...\$199.95

48-45983-3W	1935-36 3-window coupe, All\$199.95
78-45983-2D	1937-39 Tudor sedan, All.\$199.95
78-45983-2D-5W/4D	1937-39 5-W, Fordor sedan\$199.95
01A-45983-2D	1940 Tudor sedan.....	\$199.95
01A-45983-5W/4D40	5-W, Fordor sedan.....	\$199.95

TUDOR SEDAN REAR QUARTER WINDOW KITS

B-56786	1932-33 Tudor sedan.....	\$175.00
40-56786	1934 Tudor sedan & Victoria\$175.00
48-56786-F	1935 Tudor sedan (front handle).\$199.95
48-56786-C	1935-36 Tudor sedan (center handle)	..\$199.95
78-56786	1937 Tudor sedan.....	\$199.95
81A-56786	1938-40 Tudor sedan.....	\$199.95

FORDOR SEDAN REAR DOORS AND QUARTER WINDOWS

B-56791	1932 Fordor Sedan\$175.00
18-56791	1933 Fordor Sedan\$175.00
40-56791-F	1934 Fordor Sedan (Front Handle)\$175.00
40-56791-C	1934 Fordor Sedan (Center Handle)	...\$175.00
48-56791-F	35 Fordor Sedan (Front Handle)\$175.00
48-56791-C	1935-36 Fordor Sedan Rear Doors only (Center Handle)\$175.00
78-56791	1937- 38 Fordor Sedan Rear Doors only.	\$175.00
91A-56791	1939-'40 Fordor Sedan Rear Doors only.	\$175.00

COUPE REAR ROLL-DOWN WINDOW KITS

A-46108	1930-34 Coupe Rear Window\$50.00
49-46108	1935-36 Coupe Rear Window\$75.00

1932-47 PICKUP DOOR GLASS RUN KITS

B-45983-PU	1932 Pickup\$125.00
50-45983-PU	1935-37 Pickup\$195.00
81C-45983-PU	1938-39 Pickup\$195.00
01C-45983-PU	1940-47 Pickup\$195.00
7C-45983-PUD	1948-52 F-1 Pickup\$195.00



DOOR GLASS TO BODY SEAL

Holds glass into retainer and as window is rolled up, it seals glass to door window opening. Enough for two doors

B-45968	1932-38\$15.00
---------	---------	--------------

RUBBER DOOR BUMPER SETS

10-pc. set

A-702610-AS	1928-29 Coupe & tudor\$10.00
A-702610-BS	1930-31 Coupe & tudor\$10.00
B-702610	1932-36 Door bumpers each \$4.00
78-702610	1937-48 Door bumpers each \$4.00
11A-702610	1941-48 Upper door bumpers each \$4.00



VENT WINDOW RUBBER MOULDINGS

01A-7021448-S	1940 Closed pair \$75.00
01A-7112448	1940 Open. pair \$75.00
11A-7021448	1941-48 Closed pair \$75.00
11A-7112448	1941-48 Open. pair \$75.00



HOOD LACING KITS

	B-16739-S	1932 Radiator shell kit	\$20.00
	40-16739-S	1933-34 Radiator shell kit	\$20.00
	48-16739-S	1935 Radiator shell kit	\$20.00
	8-16739-S	1936 Radiator shell kit	\$20.00
	50-16739-S	1932-37 PU, Radiator shell kit .	\$20.00
	B-16740-S	1932 Cowl kit.	\$20.00
	40-16740-S	1933-34 Cowl kit.	\$20.00
	48-16740-S	1935 Cowl kit.	\$20.00
	51-16740-S	1932-37 Pickup cowl kit.	\$20.00
	68-16740-S	1936 Cowl kit.	\$20.00
	78-16740-S	1937-'40 Cowl kit	\$20.00
	11A-16740	41-1948 Cowl kit.	\$20.00

DOOR WEATHER SEAL

All sets below are enough for one car

UPPER

B-7043724	1932, 3-window coupe-kit.	\$20.00
40-7043724-A	1933-34, Coupe & Tudor sedan-kit . . .	\$20.00
40-7043724-B	1933-34, Fordor sedan-kit.	\$20.00
48-7043724-A	1935-36, Coupe & Tudor sedan-kit . . .	\$20.00
48-7043724-B	1935-36, Fordor sedan-kit.	\$20.00
78-7043724-A	1937-48, Coupe & Tudor sedan-kit . . .	\$20.00
78-7043724-B	1937-48, Fordor sedan-kit.	\$20.00
11A-7043724-A	1941-48 Back of door seal, closed car .	\$20.00
11A-7043724-B	1941-48 Back of door seal-convertible	\$20.00

LOWER

B-7043725-A	1932 Coupe & Tudor sedan-kit	\$20.00
B-7043725-B	1932 Fordor sedan-kit	\$20.00
40-7043725-A	1933-34 Coupe, Rdstr. & Tudor sedan-kit	\$20.00
40-7043725-B	1933-34 Phaeton & Fordor sedan-kit . .	\$20.00
48-7043725-A	1935-36 Coupe, Rdstr. & Tudor sedan . .	\$20.00
48-7043725-B	1935-36 Fordor sedan & touring-kit . . .	\$20.00
78-7043725-A	1937 Coupe, & Tudor sedan-kit.	\$20.00
78-7043725-B	1937 Fordor sedan & touring-kit.	\$20.00
81A-7043725-A	1938-39 Coupe & Tudor sedan-kit	\$20.00
81A-7043725-B	1938-39 Fordor sedan & convertible . .	\$20.00
01A-7043725	1940 Coupe & Tudor sedan-kit	\$20.00
11A-7043725	1941-48 Coupe & Tudor sedan, conv . .	\$20.00
46-7043725	1932-51 Pickup-kit	\$20.00

DOOR WEATHER SEAL (continued)

DOOR JAM SEAL

48-701884/5	1935-36, All body styles.	pair	\$25.00
78-711686/7	1937-40, All convertibles.	pair	\$25.00
81A-701884/5	1937-40, All closed cars	pair	\$25.00
11A-7020456/7	1941-48, All closed cars	pair	\$25.00
11A-7620456/7	1941-48, All Convertibles.	pair	\$25.00



WINDOW RUBBER

48-773540 1932-40 Bonded Quarter Window Rubber . pr \$10.00

BACK GLASS RUBBER

B-704220	1928-36-each	each	\$15.00
78-704220	1937-40 Coupes, Ford / Mercury	pair	\$30.00
81A-704220	1937-40 Sedans, pair	pair	\$30.00
01C-704220	1940-47 Pickup.	each	\$40.00
11A-704220	1941-48 Ford.	each	\$40.00
19A-704220	1941-48 Mercury.	each	\$40.00

TRUNK & RUMBLE LID SEALS

40-713540	1932-34 Coupes, Roadster	\$40.00
48-713540	1935-36 All Coupes	\$40.00
48-713540A	1935-39 Roadster Convertible.	\$40.00
48-713540H	1935-36 Tudor & Fordor.	\$40.00
78-713540	1937-40 Coupes, Sedan, Conv.	\$40.00
21A-7043720	1941-48 Tudor & Fordor.	\$40.00



91A-16761-S

RUBBER HOOD BUMPER SETS

B-16761-S	1932.	each	\$20.00
40-16761-S	1933-34.	each	\$20.00
48-16761-S	1935.	each	\$20.00
68-16761-S	1936.	each	\$20.00
78-16761-S	1937.	each	\$20.00
81A-16761-S	1938 All & 39 Standard	each	\$20.00
91A-16761-S	1939 Deluxe & 40	each	\$20.00
11A-16761	1941-48.	each	\$20.00
01C-16761	1940-41 Pickup	each	\$20.00
21C-16761	1942-47 Pickup	each	\$20.00

1928-1948 Ford Reproduction Parts



ROOF RUBBER SEAL KITS

- 48-705018-A 1935-36 Roof retaining rubber kit coupe each \$25.00
- 48-705018-B 1935-36 Top deck retaining rubber kit sedan each \$30.00



WINDSHIELD RUBBER MOLDING

- 18-701290 1932 each \$40.00
- 18-701290-B 1932, 3-window each \$40.00
- 40-701290 1933-34 each \$40.00
- 48-701290 1935-36 each \$40.00
- 40-761290 1932-34 Cabriolet each \$40.00
- 48-761290 1935-36 Cabriolet each \$55.00
- 78-701290-A 1937-39 each \$40.00
- 78-701290-BS 1937-40 Convert. & Station Wagon... pr \$75.00
- 01A-701290-S 1940 & 40-47 Pickup pair \$75.00
- 21A-701290-A 1942-48 Deluxe each \$75.00
- 21A-701290-B 1942-48 Super Deluxe each \$75.00
- 21A-761290 1942-48 Convertible each \$75.00
- 09A-70129039 1940 Mercury each \$75.00



1937-40 FRAME TO BODY PAD KIT

- Kits include all the special rubber pads used on the body mounts
- 48-5087 1935-36 \$75.00
 - 78-5087 1937-40 \$40.00
 - 11A-5084 1941 \$40.00
 - 21A-5087 1942-48 \$40.00

BODY TO FRAME WEBBING

- 2" Wide X 25' Foot Roll w/ Adhesive Back \$25.00



40-13130

HEAD LAMP STAND PAD

- B-13130-S 1932 pair \$10.00
- 40-13130-S 1933-34 pair \$10.00
- 48-13130-S 1935 pair \$10.00
- 68-13130-S1C-13130-S 1936 ... pair \$10.00



21A-13420

TAIL LAMP BRACKET RUBBER PADS

- 40-13520 1933-34 pair \$10.00
- 48-13520 1935 pair \$10.00
- 68-13520-A 1936 pair \$10.00
- 78-13520 1937 pair \$10.00
- 81A-13520 1938-39 pair \$10.00
- 01A-13420 1940 pair \$10.00
- 11A-13420 1941 pair \$10.00
- 21A-13420/1 1942-48 pair \$10.00



GAS NECK GROMMETS

- 48-9080 1935-36 \$10.00
- 91A-9080 1937-40 As above (use on most 34-40) \$10.00



FENDERWELT

- B-16070 30' Roll Black Fender Welt \$35.00
- NOTE: Other colors are available



ROADSTER WINDSHIELD FRAMES Die formed steel

- B-37105-S 1932 Chrome windshield frame \$700.00
- 40-37105-S 1933-34 Chrome windshield frame \$700.00
- B-37132-S 1932 Lower stanchions each \$90.00
- 18-37136-SS 1932 Upper stanchions pair \$140.00
- B-351000 1932-36 Wing nuts pair \$15.00
- B-37132 1932 Stanchion pads pair \$12.00
- A-18200-B 1932-35 Wind wing brackets kit \$100.00



CLOSED CAR WINDSHIELD FRAMES Die formed steel

- B-45405 1932 5/W Coupe, Sedans, Victoria & Sedan delivery \$625.00
- 40-701200 1933-34 All closed cars \$625.00



B-701276-A

B-701276-B

40-701276-A

WINDSHIELD FRAME CORNERS

- B-701276-A 1932 Closed car except 3-W pair \$18.00
- B-701276-B 1932 3-Window, chrome pair \$18.00
- 40-701276-A 1933-34 Closed Car, chrome pair \$18.00

1928-1948 Ford Reproduction Parts



WINDSHIELD DIVISION BAR

Stainless steel with nut plate

- 01A-7003078 1940 Closed Car \$40.00
- 11A-7003078 1941-48 \$40.00



40-37115-B

WINDSHIELD GARNISH MOLDINGS

- A-37115-B 1930-31 upright, stamped steelpair \$32.00
- A-37115-SS 1930-31 upright stainless steel.....pair \$40.00
- B-37115-AS 1932, Except 3-window, steelpair \$50.00
- B-37115-SSA 1932, Same as above, stainless steel . .pair \$60.00
- 40-37115-S 1933-34 All closed carspair \$50.00
- 40-37115-SS 1933-34 Stainless steelpair \$60.00



B-45463-S

A-45463-S

B-45482

B-45477-S

B-45475-S

CLOSED CAR WINDSHIELD PARTS

- A-45463-S 1928-31 Swing Armspair \$12.00
- B-45462-S 1932 Coupe and sedan swing arms . .pair \$22.00
- A-45463-S 1932-34 Pickup swing armspair \$15.00
- A-45475-S Windshield slide pivot, bolt & nut set . .pair \$4.00
- A-45477-S Windshield swing arm washerspair \$3.00
- B-45482 Windshield slide nuts, closed careach \$6.50



11A-17528

78-17529

11A-17526

11A-17527

WIPER ARMS AND BLADES

Wiper arms are exact reproductions.

- A-17655-AC Hand-operated wiper assembly each \$12.50
- A-17655-AC Hand-operated wiper assembly, chrome .ea \$17.50
- B-17529 1932-36 Wiper arm, chrome each \$5.00
- 78-17529 1937-39 Coupe and sedan wiper arm. . .ea \$15.00
- 018-17529 1937-40 Convertible, Station Wagon and '40 Coupe and sedan wiper arm each \$15.00
- 78-17530 1937-40 All, wiper arm nut each \$6.00
- B-17528 1932-36 Wiper blade, 7 3/4" each \$6.00
- 68-17528 1936-40 Wiper blade, 8 1/4" each \$6.00
- 11A-17528 1941-48 Wiper blade each \$15.00
- 11A-17526 1941-48 Wiper arm, R.H. each \$15.00
- 11A-17527 1941-48 Wiper arm, L.H. each \$15.00



78-17556

01A-17556

WIPER TRANSMISSION HOUSING PADS

- 78-17556 1937-40 Conv. & Station wagon. pair \$5.00
- 01A-17556 1940-41 Closed car pair \$5.00



78-17552/3



40-701348

40-701325

91A-701348

WINDSHIELD REGULATOR

- 40-701325 1933-34 Windshield regulator \$245.00
- 48-701325 1935-36 Windshield regulator \$245.95
- 78-701325 1937-39 Windshield regulator \$245.95
- 40-701348 1933-34 Knob chrome plated \$9.95
- 91A-701348 1939 Knob, Deluxe \$40.95
- 68-701348 1936 Chrome plated knob \$9.95
- 78-701348 1937 Chrome plated knob \$9.95

WIPER TOWERS

Complete set, includes pivot arms with chains, connecting arms.

- 78-17552/3 1937-40 Convertible and Station Wagon . \$175.00
- 01A-17552/3 1940 Closed car assembly. \$175.00



40-700616

78-700616

COWL VENT GASKETS

- 18-700616 1932 \$20.00
- 40-700616 1933-34 \$20.00
- 48-700616 1935-36 \$20.00
- 78-700616 1937-48 \$20.00

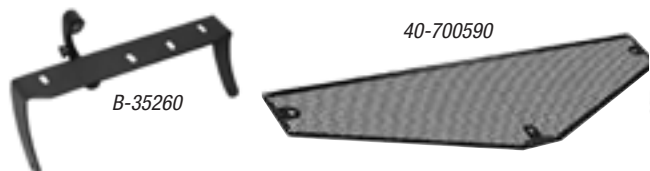

COWL VENT PARTS

B-35260	1932 Cowl Vent Hinge, vertical style	\$29.95
40-35260	1933-34 Cowl Vent Hinge	\$29.95
B-35276	1932 Cowl Vent Ratchet	\$10.00
40-35276	1933-34 Ratchet	\$10.00
B-35260	1932 Cowl Vent Spring	\$2.95
40-700590	1933-34 Screen	\$24.95
48-700590	1935-36 Screen	\$24.95



COWL VENT HANDLES

B-700611	1932 each	\$19.95
40-700611	1933-37 each	\$19.95



GLOVE BOXES

High quality reproduction with special screws and clips as needed.

40-43000	1933-34 All body styles each	\$25.00
48-43000	1935-36 Closed car each	\$25.00
48-43000-BS	1935-36 Roadster, Phaeton each	\$25.00
78-43000	1937 All body styles each	\$25.00
81A-43000	1938-39 Closed car each	\$25.00
81A-43000B	1938-39 Open car, wagon each	\$25.00
01C-43000	1940-41 Pickup each	\$25.00
01A-43000	1940 All body styles each	\$25.00
09A-43000	1940 Mercury each	\$25.00
09A-43000	1940 Mercury each	\$25.00
11A-43000	1941 All body styles each	\$25.00
21A-43000	1942-48 All body styles each	\$25.00

GLOVE BOX REPAIR KIT

40-43000-RK	1933-34 Glove Box Repair Kit	\$6.95
-------------	--	--------

GLOVE BOX DOOR STOPS AND BUMPERS

01A-7006117	1940 Rubber molded steel pair	\$7.00
48-701671	1935-'48 Glove box bumpers pair	\$2.00



DOME LIGHT

A-13771WS	1928-48 With switch	\$38.00
A-13771	1928-48 Without switch	\$38.00



INSIDE REAR VIEW MIRRORS

B-17681-SS	1932 Open car, stainless	\$60.00
B-17682-SS	1932-36 Closed car, stainless	\$60.00
B-17682	1932-36 Closed car, brown	\$60.00
40-17681SS	1933-36 Open car, stainless	\$60.00
68-17682	1935-36 Closed car	\$60.00
78-17682	1937-39 Closed car	\$60.00
01A-17682	1940 Closed car	\$60.00
11A-17682	1941-42 Closed car	\$60.00



HINGE PIN MIRROR

B-17741	1932 Closed Car (except 3-W)	\$44.95
46-17741	1932-34 Pickup, right or left	\$44.95
68-17741	1935-40 Chrome door hinge mirror bracket with hinge pin	\$44.95
50-17741	1935-'47 Pickup, chrome arm and mirror head	\$44.95



UNIVERSAL DOOR EDGE MIRROR

Show quality with straight or curved arm, 4" head and tinted lense.

A-17741-UL	Left, straight arm	\$39.95
A-17741-UR	Right, straight arm	\$39.95
B-18414L	Left, curved arm	\$39.95
B-18414R	Right, curved arm	\$39.95



HOT ROD PEEP MIRROR

No script with 3" head

HR-18414L	Left	\$39.95
HR-18414R	Right	\$39.95



SEAT BELTS

Juliano's seat belts are OEM quality and meet U.S. Federal Safety Regulations. with the correct label sewn into the webbing. Many colors to choose from

Push button lap belts	58", 60", 74" total length . . . per person	\$29.95
Chrome latch lap belts	74" total length per person	\$29.95
Push button retractable lap belts	72" per person	\$39.95
Chrome latch retractable lap belts	72" per person	\$59.95
Seat belt anchor plates per person	\$15.95



HEADLAMPS

Beautiful polished stainless reproductions with all the exterior details. Quarts units have special quarts reflectors and bulb kit pre installed.

- A-13000-CA** 1928-29 Ford script headlamp, chrome, with one-bulb reflectorpair **\$295.00**
- A-13000-CB** As above, with two-bulb reflectorpair **\$295.00**
- A-13000-CQH** 1928-29 Ford script headlamp, chrome, with 12-volt Quartz Halogen assemblies installed behind original lenspair **\$295.00**
- A-13000-SSA** 1930-31 Ford script headlamp, polished stainless steel with one-bulb reflectorpair **\$295.00**
- A-13000-SSB** As above, with two-bulb reflectorpair **\$295.00**
- A-13000-SSQH** 1930-31 Ford script headlamp, polished stainless steel with 12-volt Quartz Halogen assemblies installed behind original lenspair **\$295.00**
- B-13000-1** 1932 Headlamp, stainless with one bulb reflector.pair **\$295.00**
- B-13000-11** 1932 Headlamp, stainless with two bulb reflector.pair **\$295.00**
- B-13000-Q** 1932 Headlamp, stainless with Quartz Halogen reflector. pair **\$295.00**
- 40-13000-1** 1934 Headlamp, stainless with one bulb reflector.pair **\$295.00**
- 40-13000-Q** 1934 Headlamp, stainless with Quartz Halogen reflector. . pair **\$295.00**
- 46-13000-SS** 1934 Pickup and commercial headlamp, stainless with Quartz Halogen reflector. . pair **\$350.00**
- 46-13000** 1934 Pickup and commercial headlamp, Black w/stainless rim, Quartz Halogen reflector . . pair **\$350.00**
- HR-31555** Glide Style Hot Rod headlamp, Black with Quartz Halogen reflectorpair **\$300.00**
- HR-31555** Glide Style Hot Rod headlamp, Stainless with Quartz Halogen reflector . pair **\$325.00**

n.

- B-13027-QK** 1932 Headlamp reflect kit**\$149.95**
- 40-13027-QK** 1933-34 Headlamp reflect kit**\$149.95**
- 48-13027-QK** 1935-36 Headlamp reflect kit**\$149.95**
- 78-13027-QK** 1937-39 Headlamp reflect kit**\$149.95**
- B-13007-Q12** Headlight Bulb, Quartz Halogen, 12 Volt . . pr **\$12.00**
- B-13026-QH** Halogen headlight adapter kit, complete . **\$40.00**



STAINLESS HEADLIGHT BAR AND BOLTS

- A-13114-S** 1928-29 Model "A" Bar**\$199.95**
- A-13114-BD** 1930-31, Dropped stainless steel**\$199.95**
- 3213** 1932, Dropped stainless steel.**\$179.95**
- B-13119-SS** 1932 Polished stainless boltseach **\$5.00**



HEADLIGHT STANDS AND BOLTS

- CHP-13125/6B** 1933-34 Pass, black gloss. pair **\$35.00**
- CHP-13125/6C** 1933-34 Pass, chrome. pair **\$40.00**
- 40-13119** 1933-34 Hollow for wiring as original . . ea **\$5.00**
- 40-13119NHSS** 1933-34 Stainless with no hole.each **\$8.00**



REPRODUCTION KING BEE HEADLIGHT

Comes chrome-plated with Quartz Halogen bulb, wire and mounting hardware.

- KB-13000-C** Stainless.pair **\$120.00**

DIETZ HEADLIGHTS

Includes 12 volt sealed beam.

- Dietz Chrome Headlamp**pair **\$65.00**



40-13000-1



40-13000-1

HEADLIGHT BUCKETS

Original style buckets are stamped painted steel and include, lens and fender gaskets, reflector retainers, brackets, clips, conduit and hardware. Works with original or Bob Drake halogen reflector kits.

- 78-13026** 1937-39 Standard pair **\$285.00**
- 78-13044** 1937-39 Standard, fender gasket . . . each **\$12.00**
- 91A-13026** 1939 Deluxe pair **\$285.00**
- 01A-13026** 1940 Car, 40-41 Pickuppair **\$285.00**
- 01A-13044** 1940 fender gasket each **\$12.00**



HEADLIGHT RIMS

48-13045	1935 Car, 1935-39 Pickup	pair	\$75.00
68-13045	1936 Car	pair	\$95.00
78-13045	1937-39 Standard	each	\$35.00
1A-13045-B	1940 Deluxe Chrome	pair	\$150.00
51A-13045	1946, 1 rib style	pair	\$75.00
6A-13045	1947-48, smooth style	pair	\$75.00



TAIL LAMP LENSES

A-13450-R	1928-31 Tail lamp lens	each	\$8.00
B-13450	1932 Tail lamp lens	each	\$8.00
40-13450	1933-36 Tail lamp lens	each	\$8.00
78-134450	1937 Tail lamp lens	each	\$8.00
81A-13450	1938-39 Tail lamp lens	each	\$8.00
01A-13450	1940 Tail lamp lens	each	\$8.00
11A-13450	1941 Tail lamp lens	each	\$8.00
21A-13450	1942-48 Tail lamp lens	each	\$8.00
	Blue dot lens for any above	each	\$15.00



1940 HEADLAMP PARTS

01A-13045-A	Painted Style	pair	\$150.00
01A-13045-B	Deluxe Chrome Headlamp, Door	pair	\$150.00
01A-13082	Parking Lens, Smoked Glass	each	\$8.00
01A-13084	Parking Lens Bezel, 40 Standard	pair	\$60.00
01A-130085	1940 Parking Lens Gasket	each	\$1.00
01A-13200-T	1940 Car, 40-41 PU, turn signal conversion kit	pair	\$40.00



TAIL LAMP ASSEMBLY

B-13402-C	1932 Stainless steel, R.H.	each	\$35.00
B-13403-C	1932 Stainless steel, L.H.	each	\$35.00
40-13402	1933-34, Stainless steel, R.H.	each	\$35.00
40-13403	1933-34, Stainless steel, L.H.	each	\$35.00
48-13402	1935-36, Black w.chrome rim, R.H.	each	\$35.00
48-13403	1935-36, Black w.chrome rim, R.H.	each	\$35.00
48-13402	1935-36, Right hand	each	\$35.00
48-13403	1935-36, Left hand	each	\$35.00
78-13402	1937, Right hand	each	\$40.00
78-13403	1937, Left hand	each	\$40.00
81A-13405	1938-39 Tail light with glass lens	each	\$35.00
01A-13405	1940 Tail light with glass lens	each	\$35.00
11A-13404	1941 Passenger, R.H.	each	\$65.00
11A-13405	1941 Passenger, L.H.	each	\$65.00
21A-13405	1942-48 Passenger	each	\$35.00



COWL LIGHTS WITH TURN SIGNALS

Polished stainless steel. Complete with wiring and 12V amber bulbs.

B-13302-TS	1932 Cowl Lights	pair	\$125.00
B-13303-TS	Kit to adopt turn signals to your housings	pair	\$45.00
40-13302-TS	1933-34 Polished Stainless	pair	\$125.00



EXTRA BRITE HEADLIGHT BULBS

Fits original headlamps.

48-13007-HP12V	1935-39 12V Brite Bulbs	each	\$20.00
----------------	-------------------------	------	---------

1928-1948 Ford Reproduction Parts



TAIL LIGHT BRACKETS

B-13470	1932-37 Pickup tail light bracket	each \$15.00
18-13470	1932 Stamped steel tail light bracket, R.H.	\$35.00
18-13471	1932, As Above L.H.	each \$35.00
18-13470C	1932 Chrome, R.H.	each \$45.00
18-13471C	1932 Chrome, L.H.	each \$45.00
40-13470	1933-34 tail light bracket, for use with rumble pad, black, R.H.	each \$40.00
40-13470C	1933-34 As above, chrome	each \$40.00
40-13471	1933-34 Tail light bracket, black, L.H	each \$35.00
40-13471C	1933-34 As above, chrome	each \$45.00
78-13470	1937 Tail light bracket, black, R.H.	each \$60.00
78-13471	1937 Tail light bracket, black, L.H	each \$60.00
91C-13471	1939-47 Pickup, tail light bracket	each \$15.50

MAKE THOSE TAIL LIGHTS BRIGHT



12 Volt 50/14 candle power Same physical size as 1157 tail light bulb which has 32/3 candle power

1077 Brite Bulbs each \$7.50

LED RED COLORED TAIL LIGHT BULBS



12 Volt 1157 size socket. 5 times brighter than incandescent bulb and lasts 100 times longer. Create almost no heat.

LED 100 25 array, 1-3/4" dia . . . pair \$25.00
LED 101 11 array, 1" dia pair \$20.00



1950 PONTIAC TAILLIGHTS

Totally redesigned to make them easier to use in hot rods with a shorter bucket and centered bulb. Includes die cast chrome bezel, glass lens, 1157 bulbs, molded pad and hardware

HR-13405 Pontiac tail lights pair \$70.00
HR-13405-BD Pontiac tail lights with blue dots . . . pair \$90.00



JULIANO'S 3RD BRAKE LIGHTS FOR HOT RODS

Make your old car more visible in traffic with these easy-to-install LED 3rd brake lights. Two mount inside the back widow on the package tray and the split window version mounts on the divider.



JU018600	Billet aluminum pedestal mount	\$65.00
JU018200	Billet aluminum split window with turn signals.	\$89.95
JU018001	Black plastic pedestal mount	\$30.00



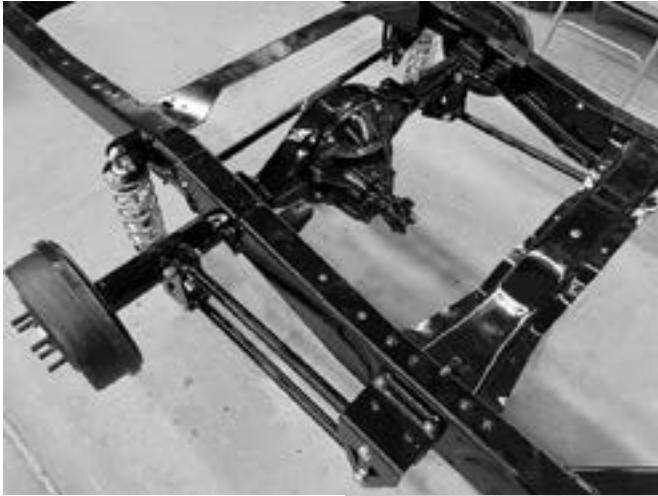

NEW!

**48-52 FORD F-1,
53-64 FORD F-100,
55-59 CHEVY**



Channel X-Frame Kit

Designed and manufactured by Heinzman Street Rods for classic trucks. Heavy-duty channel stiffens the frame and mounts the booster/master cylinder. The transmission crossmember unbolts for easy transmission removal. This kit can be bolted or welded in existing frame and is designed to work in conjunction with our rear 4-bar kit.

- X-frame kit, 5 pieces **\$750.00**
- Ford brake pedal. **\$195.00**
- Booster and master cylinder **\$225.00**

Rear 4-bar kit

Designed and manufactured by Heinzman Street Rods to bolt or weld in original classic truck frames with or without our X-frame kit. Includes the crossmember, adjustable 4-bars with poly bushing rod ends, all brackets and hardware

- 4-bars, crossmember, C-notch, brackets, hardware . . . **\$750.00**
- QA1 Coil-Overs (US404) **\$495.00**
- Panhard bar **\$125.00**

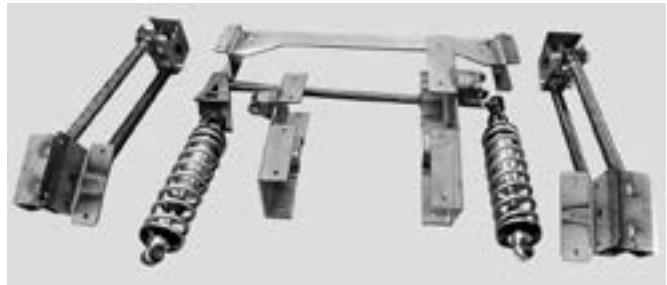

Frame X-Brace and 4-Bar Kits



Heinzman's Street Rods is a full service fabrication and restoration shop. Our experienced craftsman can tackle everything from the smallest hot rod repair job to a top chop or a complete Mustang or Camaro "G-Machine" engine and suspension conversion.

Ask us about:

- Late model Chevy LS and Ford Cobra engine swaps
- EFI conversions and wiring harnesses
- Street Rod and Classic Truck frame exchange program
- Complete sheet metal fabrication
- Complete body shop and paint booth
- Custom interiors
- Vintage Air installations
- and more!



1928-1931 Suspension

HEINZMAN STREET RODS
HOT ROD, CLASSIC
TRUCK AND MUSCLE
CAR CATALOG

From:
Heinzman Street Rods
1305 North "C" Road
Phillips, NE 68865



Call 402.886.2275 or click: www.heinzmanstreetrods.com

**PARTS FOR CHASSIS, SUSPENSIONS, BRAKES, BODIES,
SHEET METAL, ELECTRICAL, MUSCLE CAR SUSPENSIONS,
REPRODUCTION FORD PARTS AND MORE!**

**We can build you a chassis or a
complete, turnkey street rod,
classic truck or muscle car.**

